

OIL PAN

Ref No.	Part Number	Description	Qty	Remarks
1	6G8-11575-00-00	RELIEF VALVE ASSY	1	
2	93210-12M62-00	.O-RING	1	
3	6G8-15379-00-00	SEAL, CRANKCASE	1	
4	6G8-13487-00-00	GUIDE, OIL HOSE	1	
5	98580-05012-00	.SCREW, PAN HEAD	1	
6	92901-05600-00	WASHER	1	
7	6G8-15311-02-0D	OIL PAN	1	
8	6G8-15312-01-00	GASKET, OIL PAN	1	
9	6G8-13412-00-00	HOUSING, STRAINER	1	
10	97313-06016-00	BOLT, HEXAGON	1	
11	92901-06600-00	WASHER	1	
12	6G8-15315-00-00	SEAL, CRANKCASE	1	
13	6G8-15397-00-00	GASKET, O/SL HSNG	1	
14	6G8-15316-00-00	DAMPER, ENGINE MOUNT 1	1	
15	90105-06M33-00	BOLT, FLANGE	9	
16	6G8-13417-00-00	COVER, STRAINER	1	
17	6G8-13411-01-00	STRAINER, OIL	1	
18	93210-16716-00	O-RING	1	
19	6G8-15362-02-00	PLUG, OIL LEVEL	1	
20	93210-13M63-00	.O-RING	1	

CONTINUED ON NEXT FRAME >

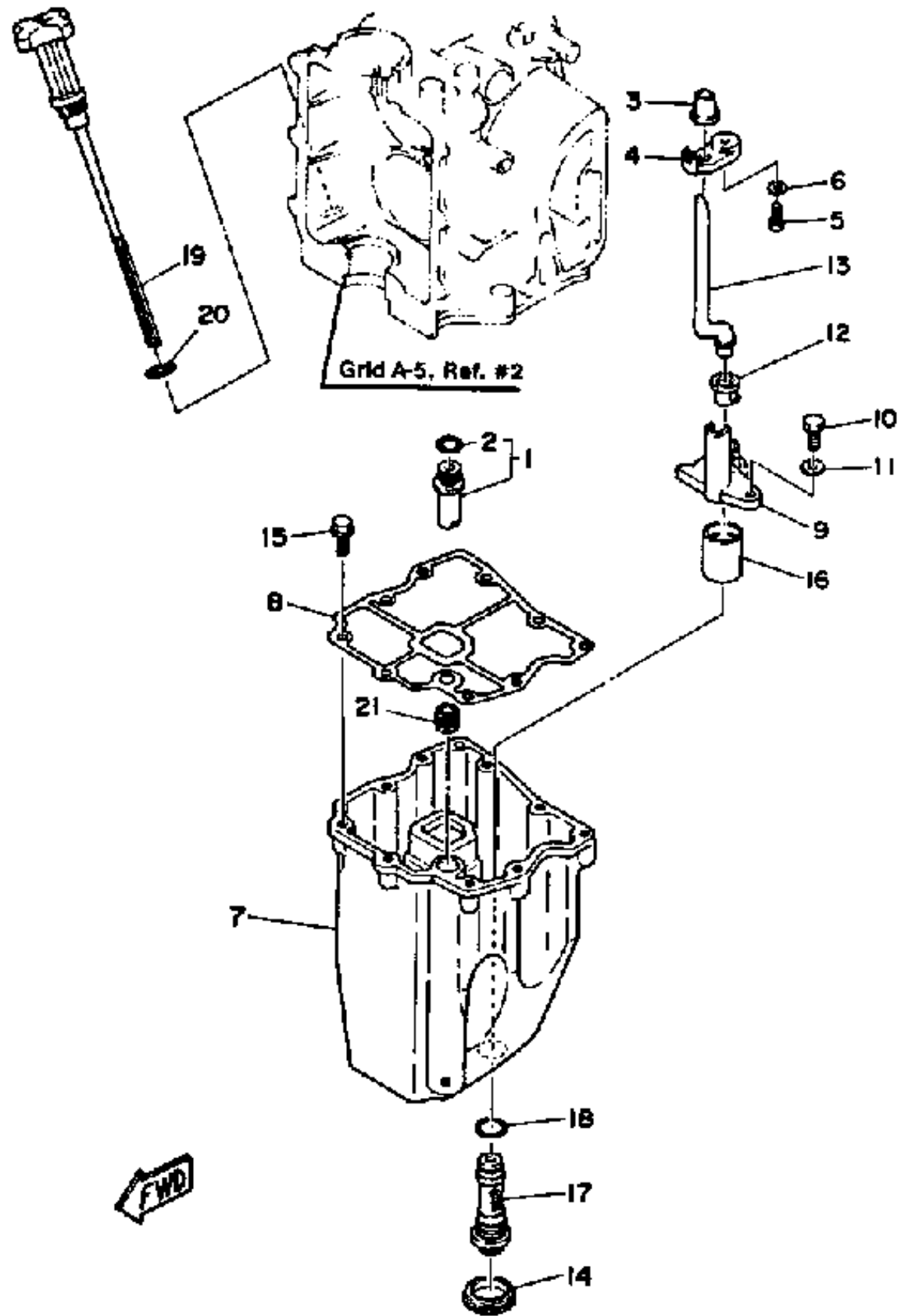

OIL PAN

Ref No.	Part Number	Description	Qty	Remarks
21	6G8-45127-00-00	SEAL	1	