

REPAIR KIT 2

Ref No.	Part Number	Description	Qty	Remarks
1	6G9-W0001-24-00	LOWER UNIT GASKET KIT	1	
2	6G8-15312-01-00	. GASKET, OIL PAN	1	
3	93210-16716-00	. O-RING	1	
4	93210-08M60-00	. O-RING	1	
5	93101-13M27-00	. O-RING	1	
6	6G8-41133-A0-00	. GASKET, EXHAUST MANIFOLD 1	1	
7	6G8-45113-A0-00	. GASKET, UPPER CASING	1	
8	90430-08020-00	. .GASKET	3	
9	682-44315-A0-00	. GASKET, WATER PUMP	2	
10	93101-20048-00	. .OIL SEAL	2	
11	683-45315-A0-00	. PACKING, LOWER CASING	1	
12	93101-17054-00	. .OIL SEAL	2	
13	93210-57M09-00	. .O-RING	1	
14	682-45375-01-00	. DAMPER, SEAL	1	
15	626-44365-01-00	. DAMPER, WATER SEAL	1	
16	682-W0078-01-00	WATER PUMP REPAIR KIT	1	
17	682-44365-00-00	. DAMPER, WATER SEAL	1	
18	97395-06040-00	. BOLT	4	
19	682-44322-00-00	. INSERT, CARTRIDGE	1	
20	682-44352-01-00	. IMPELLER	1	

CONTINUED ON NEXT FRAME >

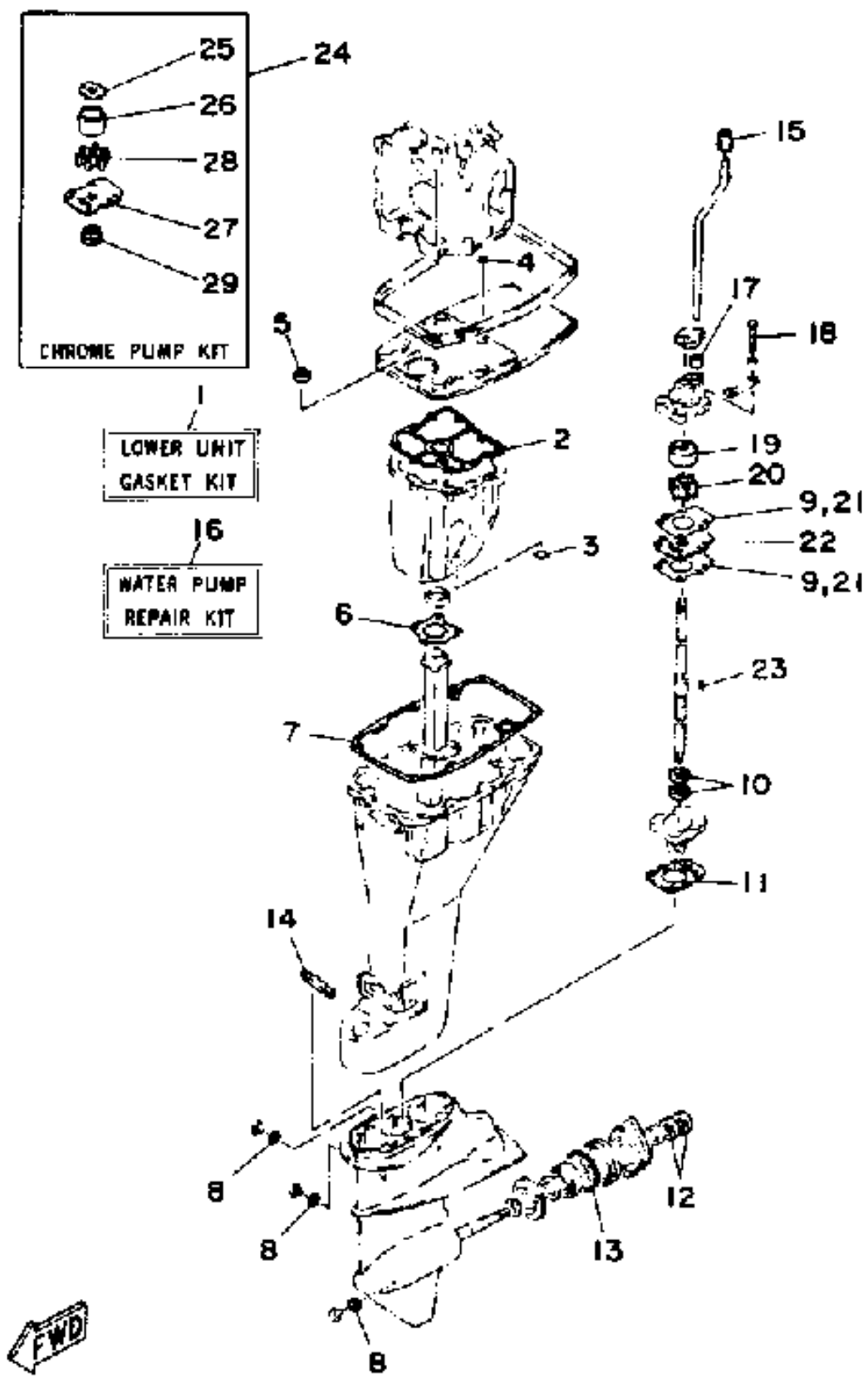

REPAIR KIT 2

Ref No.	Part Number	Description	Qty	Remarks
21	682-44315-A0-00	GASKET, WATER PUMP	2	
22	682-44323-00-00	. OUTER PLATE, CARTRIDGE	1	
23	90280-03024-00	. .KEY, WOODRUFF	1	
24	682-W0078-0A-00	CHROME PUMP KIT	1	
25	682-44321-40-00	. INNER PLATE, CARTRIDGE	1	
26	682-44322-40-00	. INSERT, CARTRIDGE	1	
27	682-44323-40-00	. OUTER PLATE, CARTRIDGE	1	
28	682-44352-01-00	. IMPELLER	1	
29	682-45344-00-00	. COVER, OIL SEAL	1	