

CRANKSHAFT PISTON

Ref No.	Part Number	Description	Qty	Remarks
1	63V-15396-00-00	HOUSING, OIL SEAL	1	
2	93210-46M16-00	.O-RING	1	
3	93102-25M48-00	.OIL SEAL	1	
4	93101-13M11-00	OIL SEAL	1	
5	97095-06016-00	BOLT	1	
6	92990-06600-00	.WASHER, PLATE	1	
7	63V-11400-00-00	CRANKSHAFT ASSEMBLY	1	
8	63V-11412-00-00	. CRANK 1	1	
9	63V-11422-00-00	. CRANK 2	1	
10	63V-11432-00-00	. CRANK 3	1	
11	63V-11442-00-00	. CRANK 4	1	
12	93306-205U7-00	. BEARING	3	
13	63V-11515-00-00	. SEAL, LABYRINTH 1	1	
14	682-11681-00-00	. PIN, CRANK 1	2	
15	650-11651-04-00	. ROD, CONNECTING	2	
16	93310-620V5-00	. BEARING	2	
17	90209-20159-00	. WASHER	4	
18	6E7-11631-00-97	PISTON (STD)	2	
18	6E7-11636-00-00	PISTON (0.50MM O/S)	2	AP
18	6E7-11635-00-00	PISTON (0.25MM O/S)	2	AP

CONTINUED ON NEXT FRAME >

FWD
63VJA-5020

9_9_mh_eh_er_v

A4

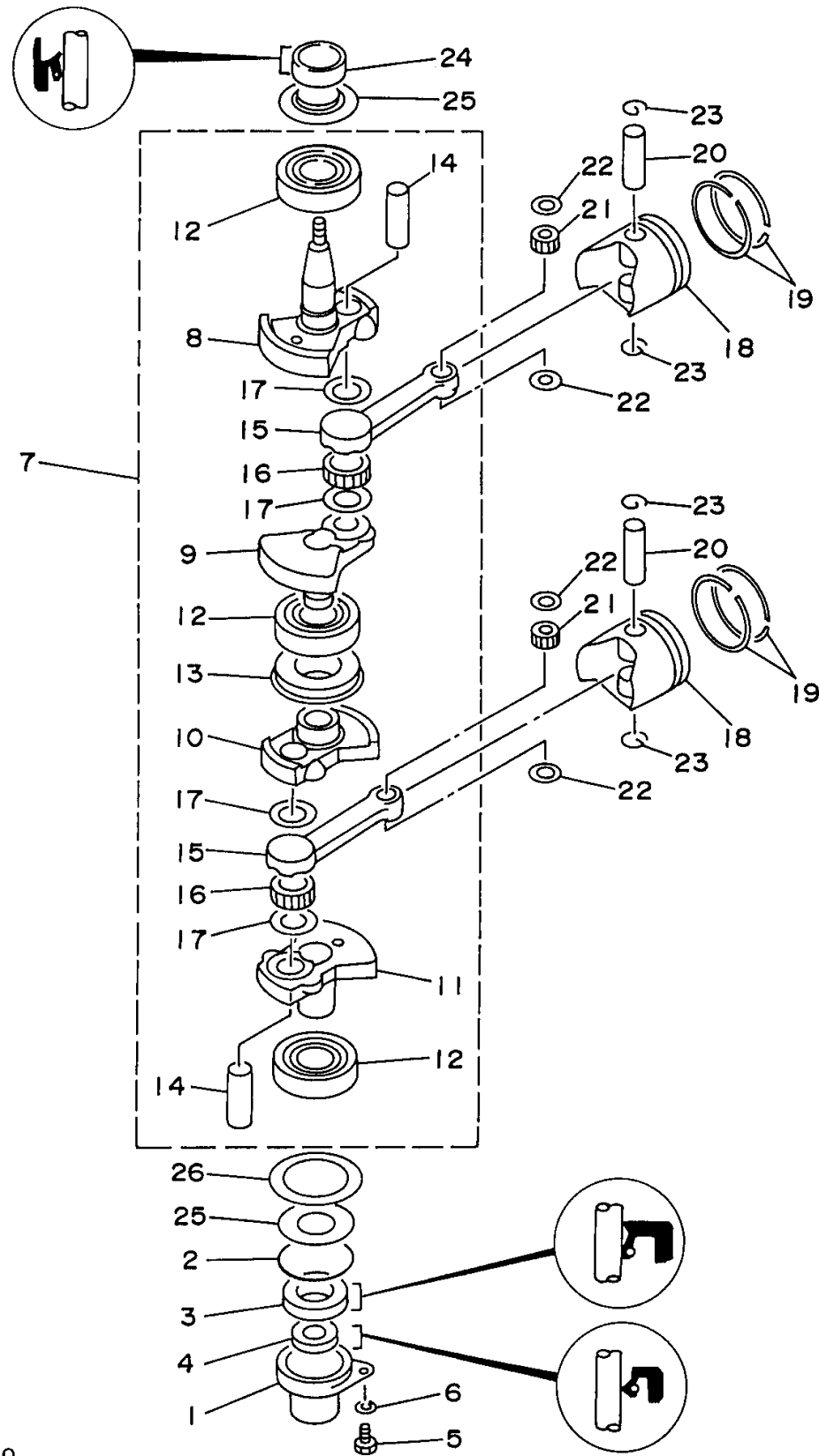

CRANKSHAFT PISTON

Ref No.	Part Number	Description	Qty	Remarks
19	682-11610-01-00	PISTON RING SET (STD)	2	
19	682-11610-21-00	PISTON RING SET (0.50MM O/S)	2	AP
19	682-11610-11-00	PISTON RING SET (0.25MM O/S)	2	AP
20	634-11633-00-00	PIN, PISTON	2	
21	93602-14104-00	PIN, DOWEL	50	
22	90201-14377-00	WASHER, PLATE	4	
23	93450-15023-00	CIRCLIP	4	
24	93110-23M00-00	.OIL SEAL	1	
25	63V-11445-00-00	.SPACER	2	
26	90201-46M29-00	.WASHER, PLATE	1	



63VJA-5020

9_9_mh_eh_er_v

A5