

MAIN HOUSING UP TO SERIAL 59499

Ref No.	Part Number	Description	Qty	Remarks
1	6E5-JD009-41-00	MAIN HOUSING W/EX. TUBE	1	115/200 HP MODEL
1	6H1-JD009-08-00	MAIN HOUSING W/EX. TUBE	1	90 HP MODEL
2	6H4-JD006-31-00	DOWEL PIN	2	
3	6H4-JD009-75-00	GREASE HOSE	1	
4	6H4-JD005-39-00	GREASE FITTING	1	
5	6H4-JD008-46-00	U-BOLT	1	
6	6H4-JD006-21-00	NUT, NYLOC	2	
7	6H1-JD001-28-00	EXHAUST TUBE	1	
8	6H4-JD001-16-90	GATE BUMPER	1	
9	6H1-JD001-03-40	SHIFT CAM LARGE	1	
10	6H4-JD001-04-30	SHAFT, ROLLER	1	
11	6H1-JD005-73-00	BOLT	1	
12	63D-JD005-53-02	BALL END	1	
13	6H4-JD006-23-00	NYLOC	1	
14	6H4-JD005-74-10	BOLT, HEX HEAD NYLOC	1	
15	6H4-JD001-03-60	CAM, ECCENTRIC DRILLED	1	
16	6H4-JD001-04-20	SHAFT, ROLLER	1	
17	6H4-JD006-35-00	WASHER, PLAIN	1	
18	6H4-JD006-24-00	NUT, FIBER LOCK	1	
19	6H4-JD001-56-00	BRACKET, CABLE SUPPORT	1	

CONTINUED ON NEXT FRAME >

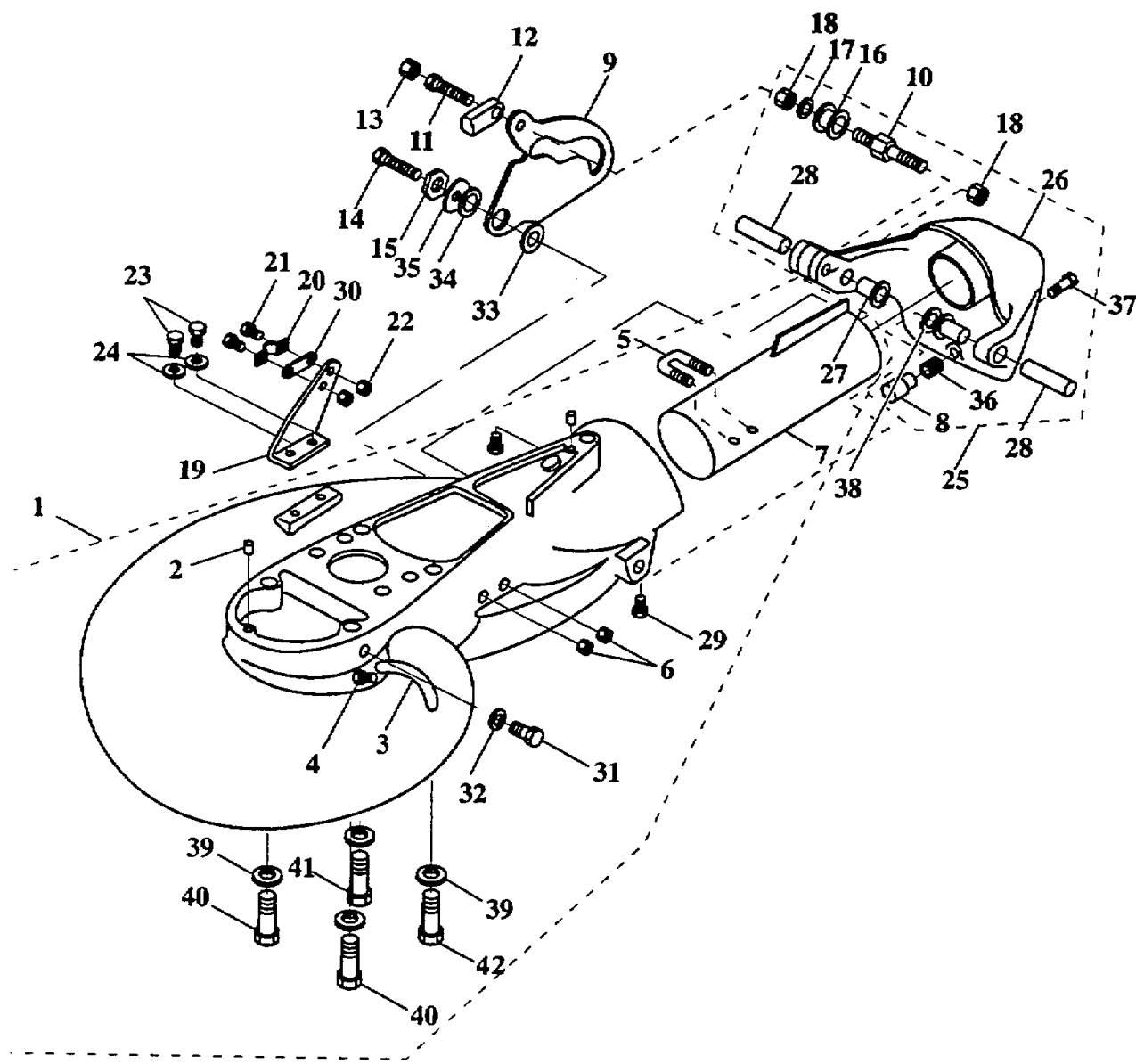

MAIN HOUSING UP TO SERIAL 59499

Ref No.	Part Number	Description	Qty	Remarks
20	6H4-JD005-43-00	CABLE CLAMP	1	
21	6H4-JD005-61-00	SCREW, FIL HEAD	2	
22	6H4-JD006-19-00	NUT, FIBER LOCK	2	
23	6H4-JD005-72-00	BOLT	2	
24	6H4-JD006-35-00	WASHER, PLAIN	2	
25	6H1-JD001-17-30	GATE ASSY LARGE CAM 1/2"	1	
26	6H1-JD011-72-01	GATE, PAINTED CAM LARGE 12"	1	
27	6H1-JD005-36-00	NYLINER 4217A 1/2 ID X .82"	2	
28	6H1-JD008-23-00	. PIN, REVERSE PIVOT	2	
29	6H4-JD005-74-00	. BOLT	2	
30	6H4-JD005-42-00	SHIM	1	
31	6H4-JD001-02-40	FLUSH SCREW	1	
32	6H4-JD001-02-50	WASHER, FIBER M8	1	
33	6H4-JD001-03-70	BUSHING, CAM	1	
34	6H4-JD001-03-80	WASHER, CAM	1	
35	6H4-JD001-03-90	SHIM, CAM	1	
36	6H4-JD001-17-00	SPRING, GATE BUMPER	1	
37	6H4-JD005-58-00	SCREW, FIL HD SLOTTED	1	
38	6H1-JD001-17-80	SPRING GATE PIVOT 1/2	1	
39	6H1-JD006-36-00	WASHER, SPRING LOCK M10	4	

CONTINUED ON NEXT FRAME >

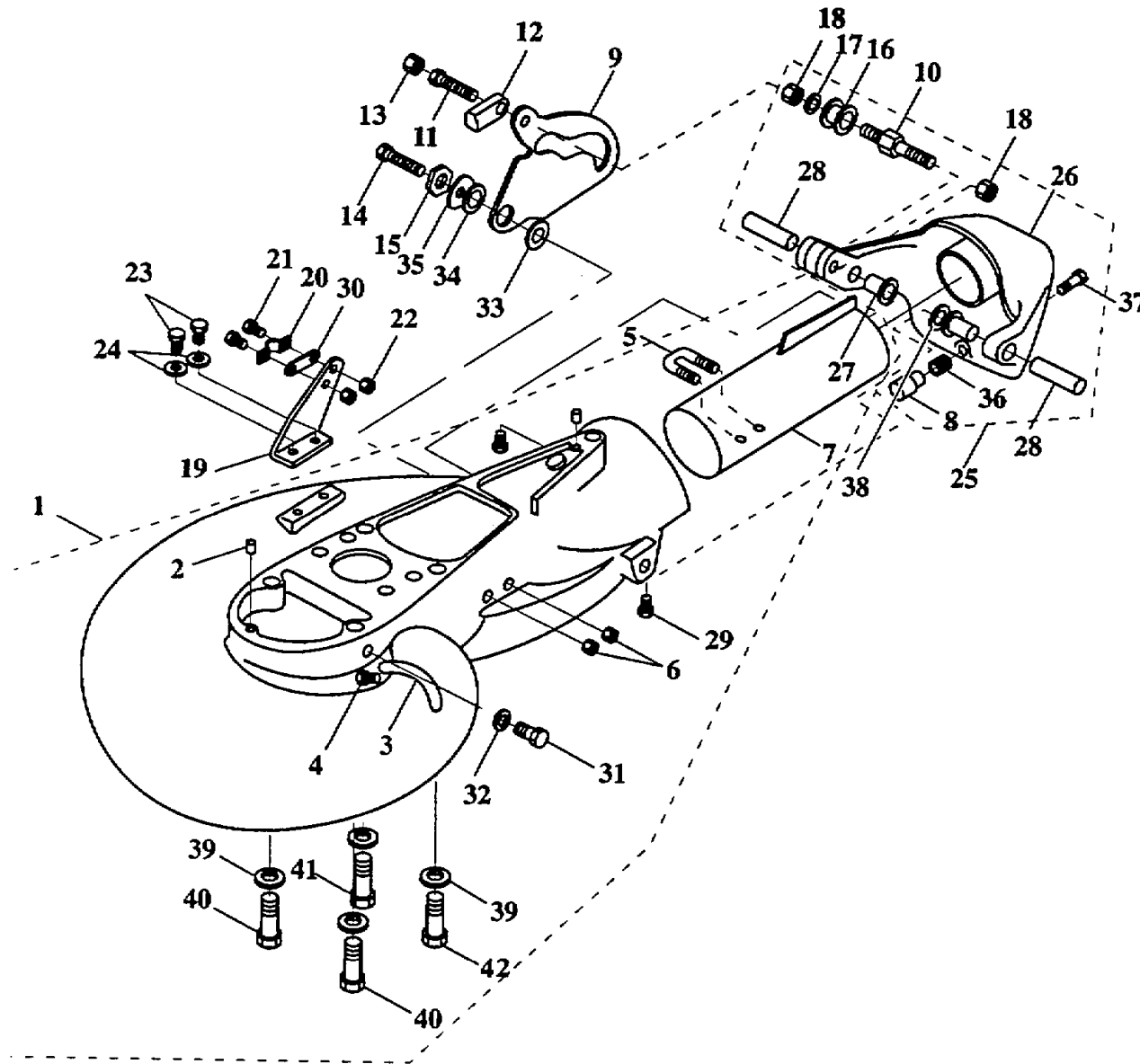

MAIN HOUSING UP TO SERIAL 59499

Ref No.	Part Number	Description	Qty	Remarks
40	6H1-JD006-08-00	BOLT 3/8-16 X 2-1/4"	2	
41	6H1-JD006-09-00	BOLT 3/8-16 X 2-3/4"	1	
42	6H1-JD006-10-00	BOLT 3/8-16 X 3"	1	

