

OIL PAN

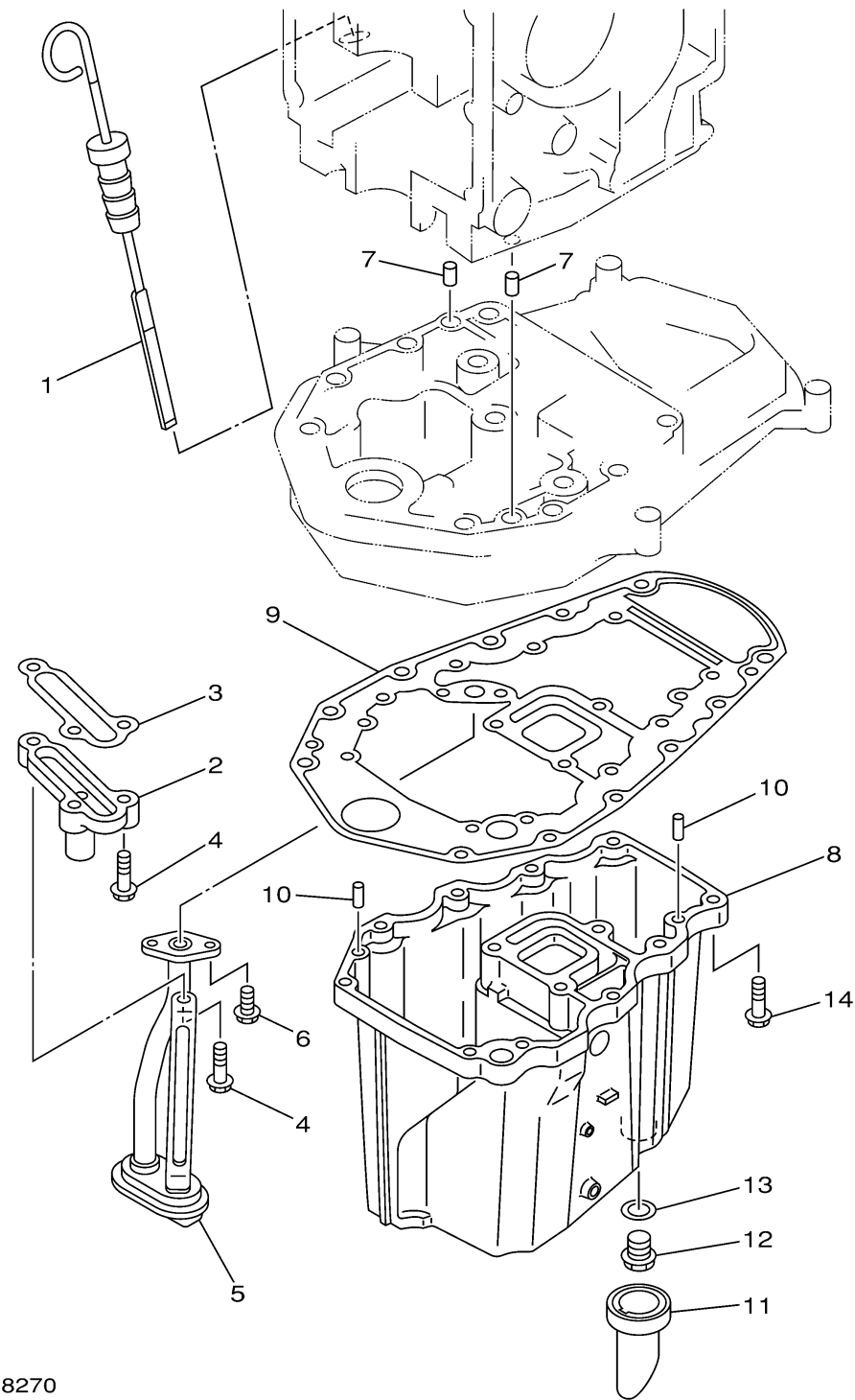

35W0010-8270

Ref No.	Part Number	Description	Qty	Remarks
1	65W-15362-01-00	PLUG, OIL LEVEL	1	
2	62Y-11575-00-00	RELIEF VALVE ASSY	1	
3	62Y-13475-00-00	.GASKET	1	
4	97513-06525-00	BOLT, WITH WASHER	3	
5	65W-13411-00-00	STRAINER, OIL	1	
6	97513-06516-00	BOLT, WITH WASHER	2	
7	93608-12M05-00	PIN, DOWEL	2	
8	65W-15311-01-5B	OIL PAN	1	
9	62Y-15312-00-00	GASKET, OIL PAN	1	
10	93606-12019-00	PIN, DOWEL	4	
11	65W-15316-00-00	DAMPER 1	1	
12	90340-14M06-00	PLUG, STRAIGHT SCREW	1	
13	90430-14M09-00	.GASKET	1	
14	97575-06525-00	BOLT, WITH WASHER	10	