

# CRANKSHAFT PISTON

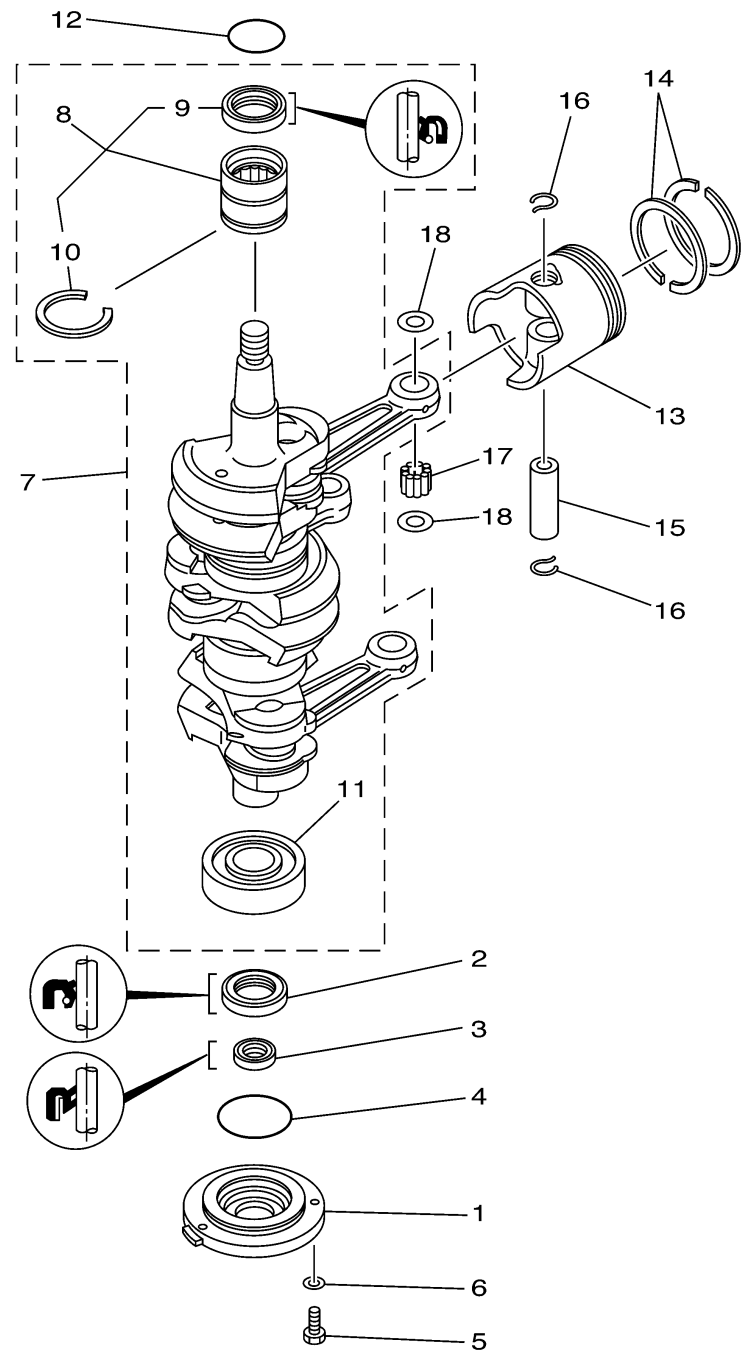

Ref No.	Part Number	Description	Qty	Remarks
1	6H3-15359-00-94	HOUSING, OIL SEAL	1	
2	93102-30M23-00	OIL SEAL	1	
3	93106-18M01-00	OIL SEAL	1	
4	93210-65M50-00	O-RING	1	
5	97095-06020-00	BOLT	3	
6	92995-06600-00	WASHER	3	
7	6H3-11400-03-00	CRANKSHAFT ASSY	1	
8	93311-636U6-00	. .BEARING	1	
9	93102-36M24-00	. . OIL SEAL	1	
10	93440-49M04-00	. . CIRCLIP	1	
11	93306-306V1-00	. .BEARING	1	
12	93210-46M16-00	.O-RING	1	
13	6H3-11635-01-00	PISTON (0.25MM O/S)	3	AP
13	6H3-11631-01-96	PISTON (STD)	3	
13	6H3-11636-01-00	PISTON (0.50MM O.S.)	3	AP
14	6K5-11601-12-00	PISTON RING SET (0.25MM O/S)	3	AP
14	6K5-11601-22-00	PISTON RING SET (0.50MM O.S.)	3	AP
14	6K5-11601-02-00	PISTON RING SET (STD)	3	
15	6H3-11633-00-00	PIN, PISTON	3	
16	688-11634-10-00	CLIP, PISTON PIN	6	

CONTINUED ON NEXT FRAME >



6H20010-0030

# CRANKSHAFT PISTON

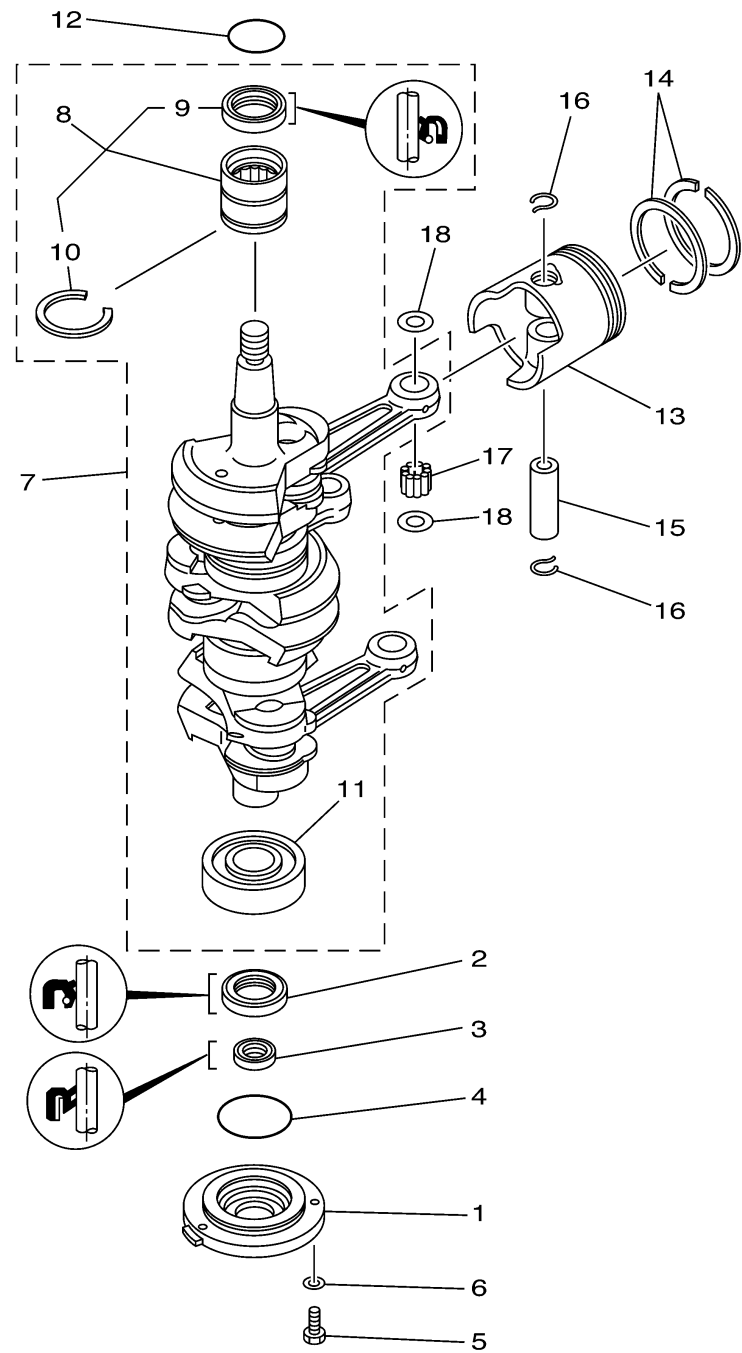

Ref No.	Part Number	Description	Qty	Remarks
17	93603-18M09-00	PIN, DOWEL	84	
18	90201-20417-00	WASHER, PLATE	6	



6H20010-0030