

# CYLINDER CRANKCASE

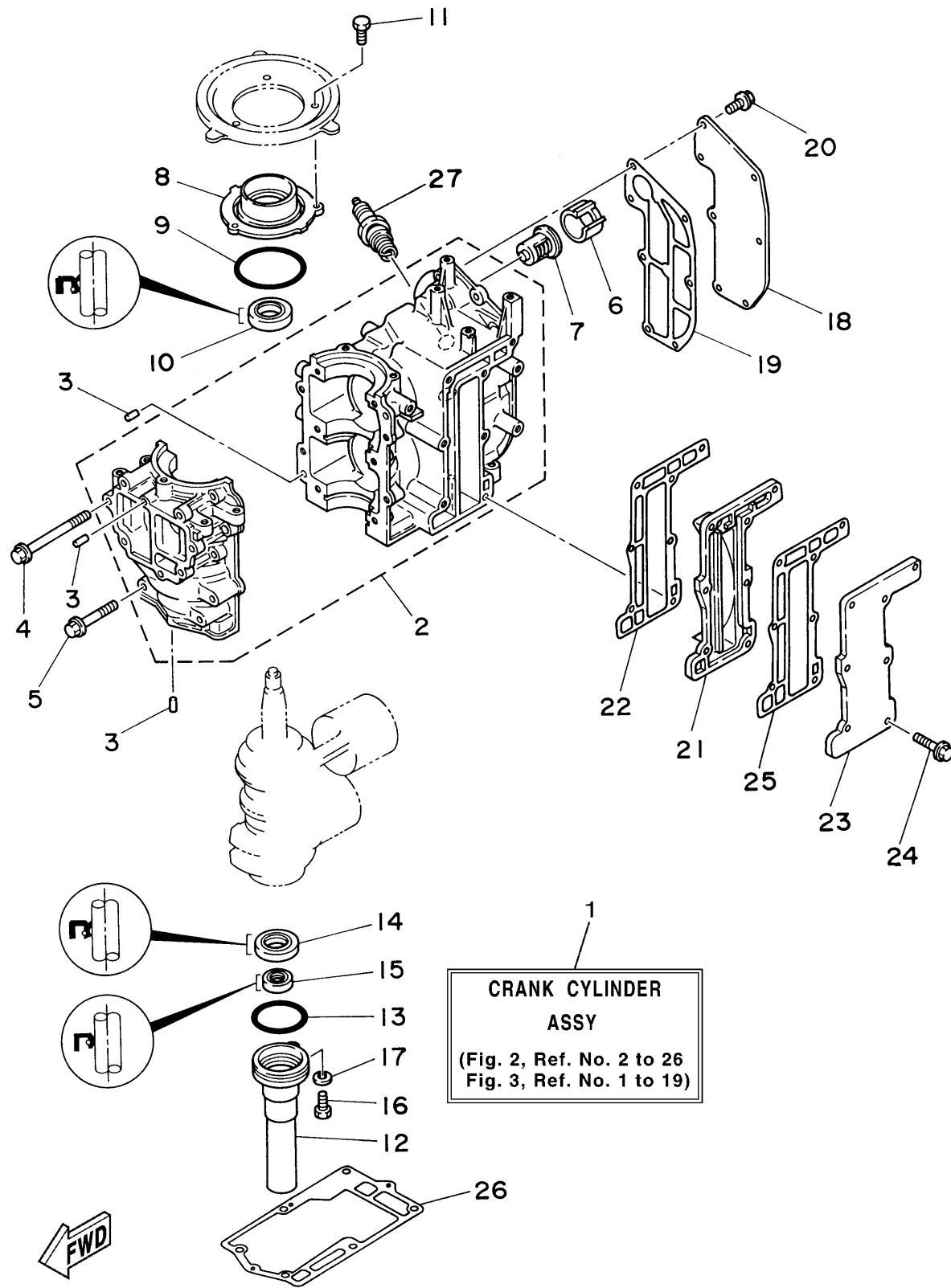

Ref No.	Part Number	Description	Qty	Remarks
1	6N0-W0090-00-4D	CRANK CYLINDER ASSY	1	(8MH)
2	6N0-E5100-00-94	CRANKCASE ASSY	1	(8MH)
3	93604-08062-00	PIN, DOWEL	4	(8MH)
4	90105-06M26-00	BOLT, FLANGE	6	(8MH)
5	90105-06M25-00	BOLT, FLANGE	4	(8MH)
6	90387-22M50-00	COLLAR	1	(8MH)
7	6E5-12411-01-00	THERMOSTAT	1	(8MH)
8	6G1-15359-01-94	HOUSING, OIL SEAL	1	(8MH)
9	93210-54M54-00	O-RING	1	(8MH)
10	93102-20M25-00	OIL SEAL	1	(8MH)
11	97013-06016-00	BOLT	3	(8MH)
12	6G1-15396-02-5B	HOUSING, OIL SEAL	1	(8MH)
13	93210-42159-00	.O-RING	1	(8MH)
14	93101-20M34-00	.OIL SEAL	1	(8MH)
15	93101-12M26-00	.OIL SEAL	1	(8MH)
16	97095-06016-00	BOLT	1	(8MH)
17	92995-06600-00	WASHER	1	(8MH)
18	6N0-E1191-00-9M	COVER, CYLINDER HEAD 1	1	(8MH)
19	6G1-11193-A1-00	.GASKET, HEAD COVER 1	1	(8MH)
20	90105-06M14-00	BOLT FLANGE	7	(8MH)

CONTINUED ON NEXT FRAME >

6M80100-7020

8msha

A6

# CYLINDER CRANKCASE

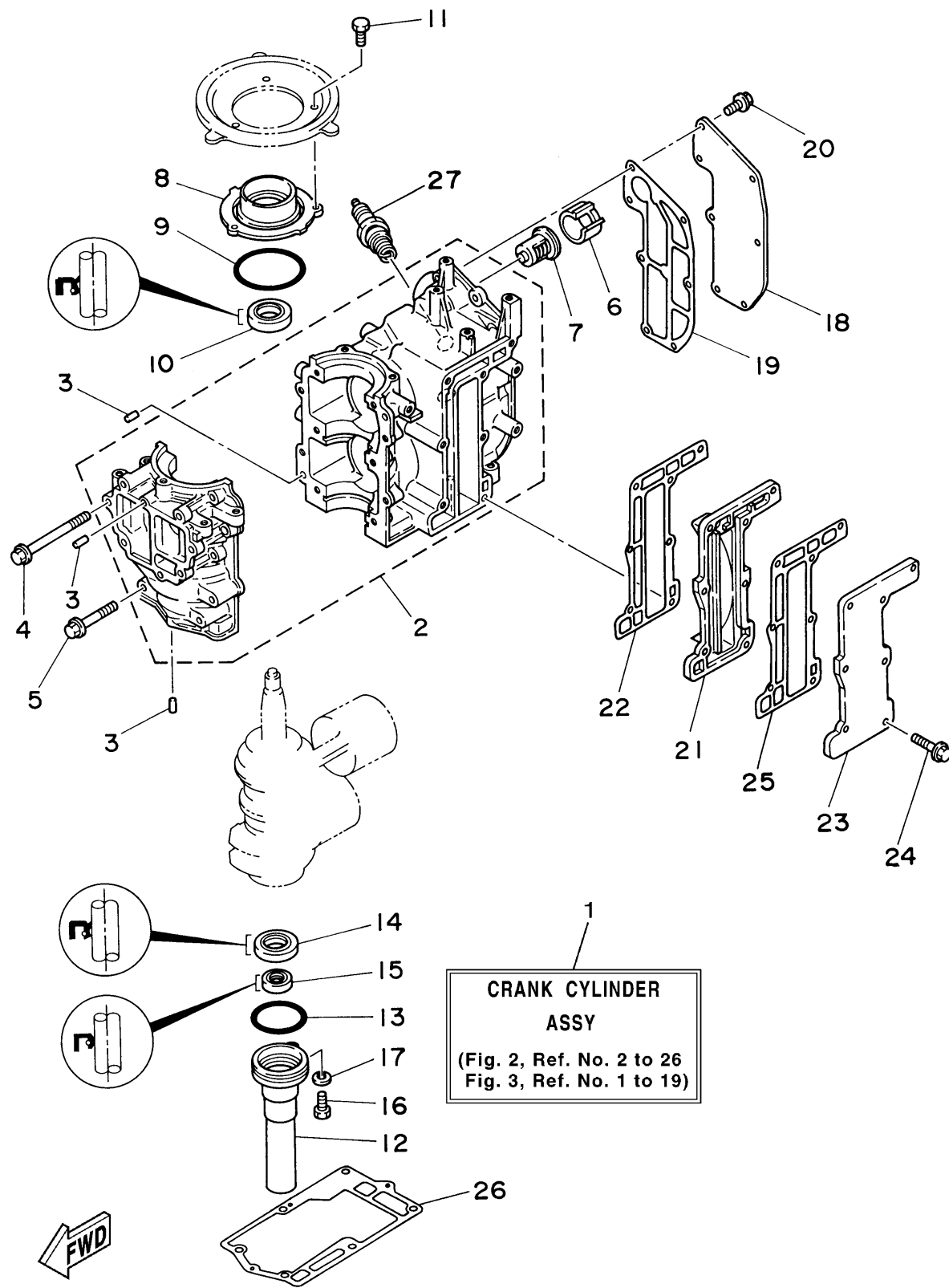

Ref No.	Part Number	Description	Qty	Remarks
21	6N0-G1111-00-9M	INNER COVER, EXHAUST	1	(8MH)
22	6G1-41112-A1-00	.GASKET, EXHAUST INNER COVER	1	(8MH)
23	6G1-41113-01-9M	OUTER COVER, EXHAUST	1	(8MH)
24	90105-06M24-00	BOLT, FLANGE	7	(8MH)
25	6G1-41114-A0-00	GASKET, EXHAUST OUTER COVER	1	(8MH)
26	6G1-45113-A1-00	GASKET, UPPER CASING	1	(8MH)
27	NGK-B7HS1-00-00	PLUG, SPARK (NGK B7HS-10)	2	(8MH)

6M80100-7020

8msha

A7