

## CYLINDER CRANKCASE 2

Ref No.	Part Number	Description	Qty	Remarks
1	68D-E1311-01-94	CYLINDER 1	1	(F4)
2	650-24378-00-00	. .PIPE, JOINT 4	1	(F4)
3	6H1-14485-00-00	. .PIPE, JOINT	3	(F4)
4	90445-07806-00	HOSE (L167)	1	(F4)
5	93102-25090-00	.OIL SEAL	1	(F4)
6	93306-205YD-00	BEARING	1	(F4)
7	68D-E5111-00-94	CRANKCASE 1	1	(F4)
8	650-24378-00-00	. .PIPE, JOINT 4	1	(F4)
9	68D-11351-A0-00	.GASKET, CYLINDER	1	(F4)
10	97575-08550-00	BOLT, WITH WASHER	7	(F4)
11	99510-10114-00	PIN, DOWEL	2	(F4)
12	97095-08020-00	BOLT	1	(F4)
13	92995-08600-00	WASHER	1	(F4)
14	90430-08209-00	.GASKET	1	(F4)
15	68D-E5396-00-5B	HOUSING, OIL SEAL	1	(F4)
16	93210-35537-00	O-RING	1	(F4)
17	93102-20108-00	OIL SEAL	1	(F4)
18	93102-10004-00	.OIL SEAL	2	(F4)
19	97095-08020-00	BOLT	1	(F4)
20	92995-08600-00	WASHER	1	(F4)

CONTINUED ON NEXT FRAME >



67D0010-8040  
f4msha\_mlha

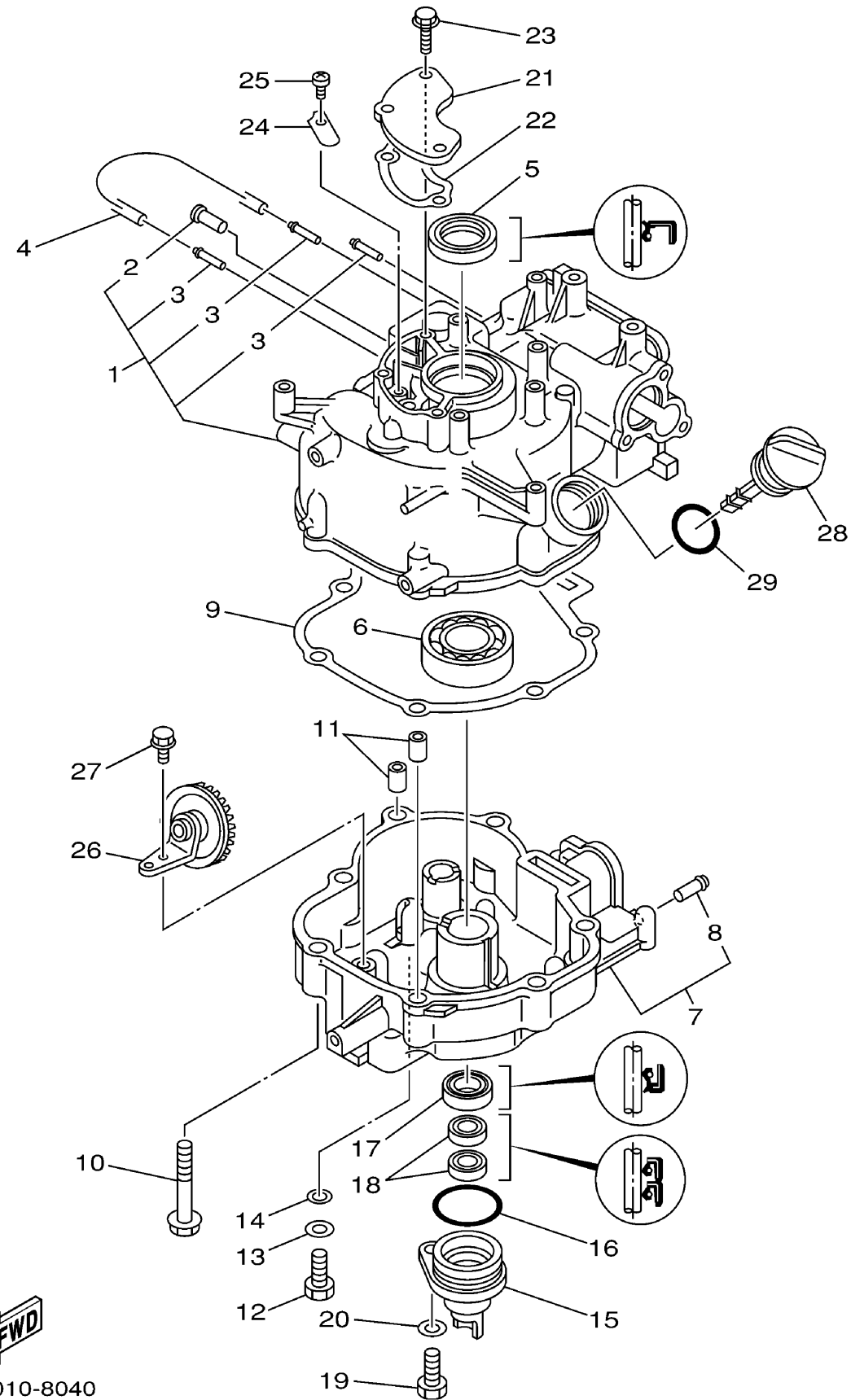

## CYLINDER CRANKCASE 2

Ref No.	Part Number	Description	Qty	Remarks
21	68D-E1168-00-00	COVER, BREATHER	1	(F4)
22	68D-E1169-A0-00	.GASKET, BREATHER COVER	1	(F4)
23	90119-06M80-00	BOLT, WITH WASHER	3	(F4)
24	68D-E5346-00-00	BREATHER 1	1	(F4)
25	98503-04006-00	SCREW, PAN HEAD	1	(F4)
26	68D-E3102-00-00	GEAR UNIT ASSY	1	(F4)
27	95817-06012-00	BOLT, FLANGE	1	(F4)
28	68D-E5362-00-00	PLUG, OIL LEVEL	1	(F4)
29	93210-24M79-00	.O-RING	1	(F4)



67D0010-8040  
f4msha\_mlha