

# GENERATOR

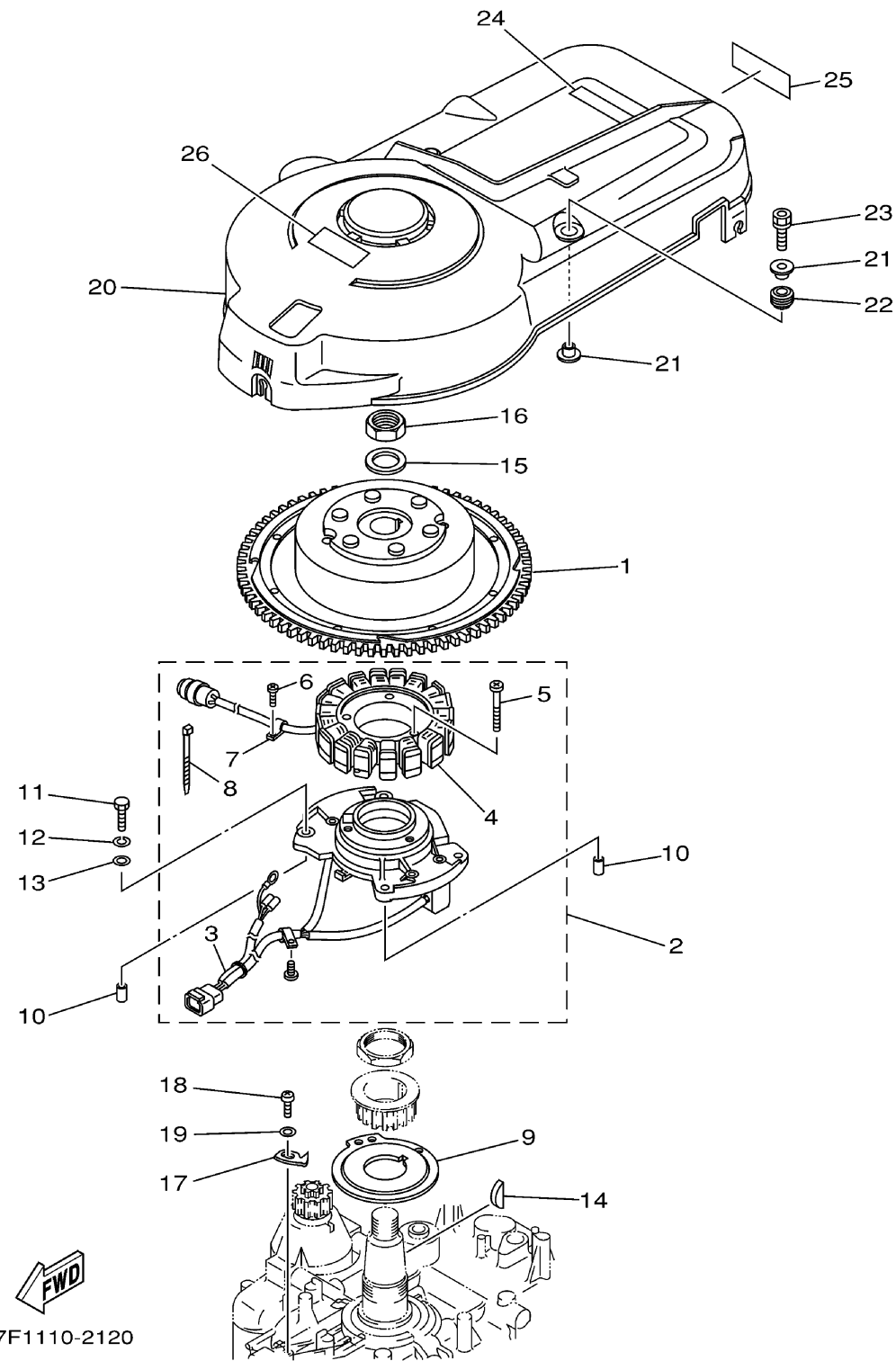

67F1110-2120

Ref No.	Part Number	Description	Qty	Remarks
1	67F-85550-00-00	ROTOR ASSY	1	
2	67F-85560-01-00	BASE ASSY	1	
3	67F-85580-00-00	. .COIL, PULSER	1	
4	67F-85510-01-00	. .STATOR ASSY	1	
5	63D-81345-20-00	. .SCREW, WITH WASHER (M6X30)	3	
6	97607-04110-00	. . . SCREW, WITH WASHER	1	
7	445-81328-20-00	. CLAMP	1	
8	66T-81328-00-00	. .CLAMP	1	
9	67F-81673-00-00	ROTOR	1	
10	99530-08012-00	PIN, DOWEL	2	
11	97095-06030-00	BOLT	4	
12	92995-06100-00	WASHER, SPRING	4	
13	92995-06600-00	WASHER	4	
14	90280-05015-00	KEY, WOODRUFF	1	
15	90201-24014-00	WASHER, PLATE	1	
16	90179-24002-00	NUT	1	
17	67F-81332-00-00	PLATE, TIMING	1	
18	97885-06010-00	SCREW, PAN HEAD	1	
19	92995-06600-00	WASHER	1	
20	67F-81337-01-00	COVER, FLYWHEEL	1	

CONTINUED ON NEXT FRAME >

# GENERATOR

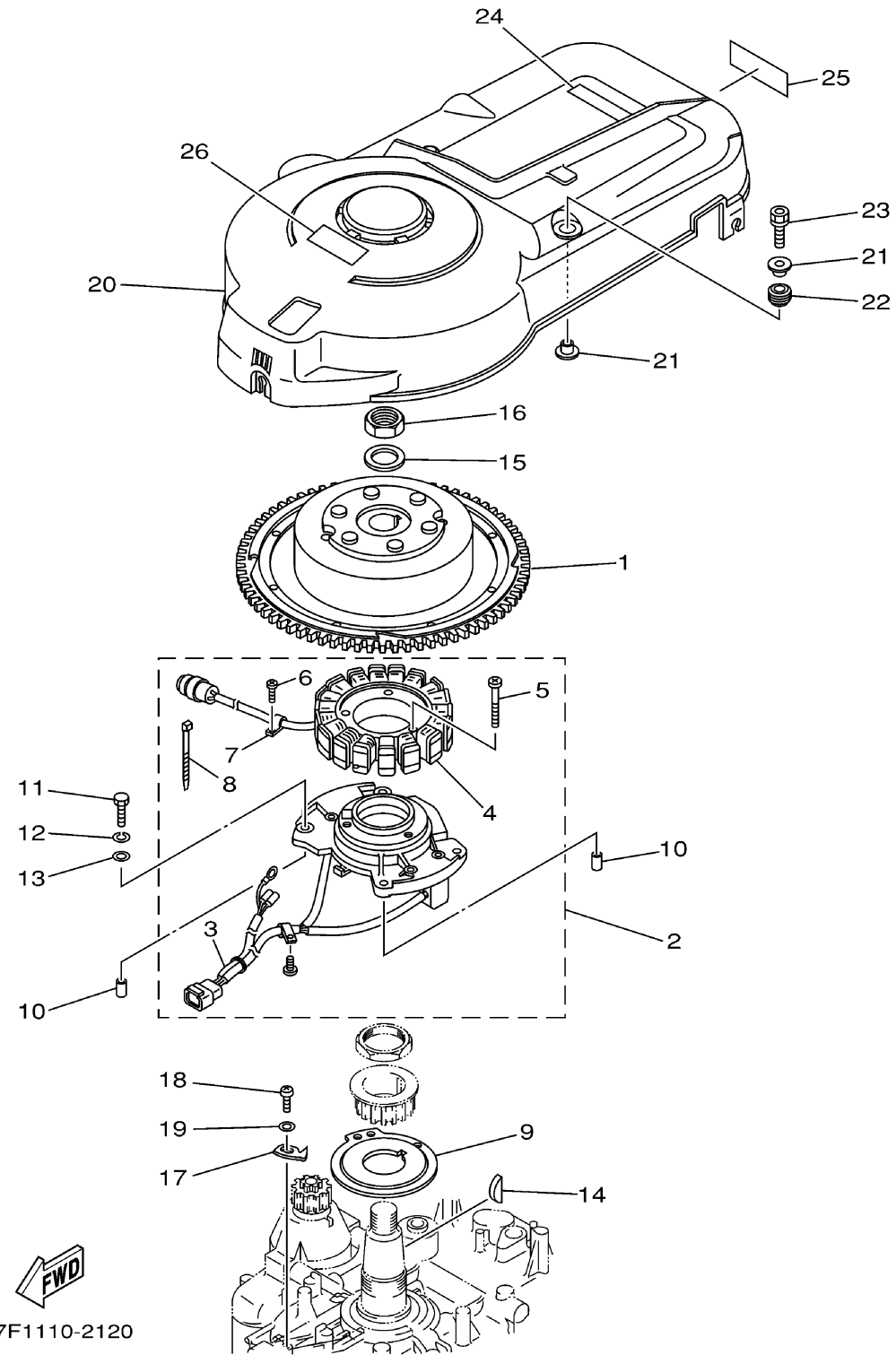

Ref No.	Part Number	Description	Qty	Remarks
21	90387-06M71-00	COLLAR	4	
22	90480-15M31-00	GROMMET	2	
23	90119-06M92-00	BOLT, WITH WASHER	2	
24	67F-12138-40-00	MARK, CAUTION	1	
25	67F-13437-41-00	MARK, CAUTION	1	
26	6A1-83625-41-00	MARK 5	1	