

# ELECTRICAL 1

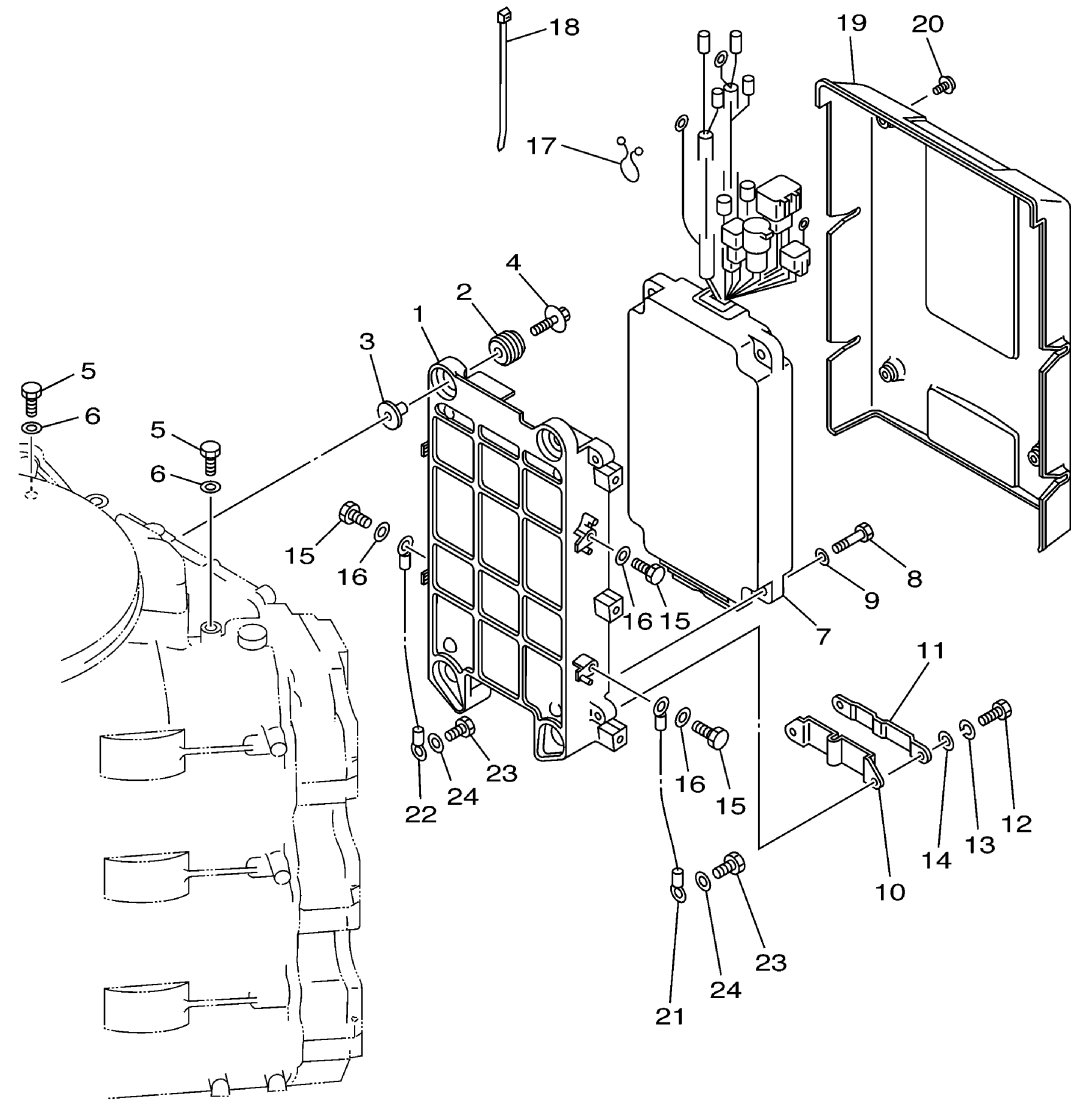

| Ref No. | Part Number     | Description       | Qty | Remarks         |
|---------|-----------------|-------------------|-----|-----------------|
| 1       | 61A-85542-01-94 | BRACKET           | 1   |                 |
| 2       | 90480-09M12-00  | GROMMET           | 4   |                 |
| 3       | 90387-06M03-00  | COLLAR            | 4   |                 |
| 4       | 90119-06M28-00  | BOLT, WITH WASHER | 4   |                 |
| 5       | 97013-06016-00  | BOLT              | 2   |                 |
| 6       | 92903-06600-00  | WASHER, PLATE     | 2   |                 |
| 7       | 65L-85540-02-00 | C.D.I. UNIT ASSY  | 1   | UR SX250, SX250 |
| 7       | 65J-85540-02-00 | C.D.I. UNIT ASSY  | 1   | UR SX225, LX225 |
| 8       | 97013-06025-00  | BOLT              | 4   |                 |
| 9       | 92903-06600-00  | WASHER, PLATE     | 4   |                 |
| 10      | 61A-85548-00-00 | HOLDER            | 1   |                 |
| 11      | 61A-85525-00-00 | COVER             | 1   |                 |
| 12      | 97095-06016-00  | BOLT              | 2   |                 |
| 13      | 92995-06100-00  | WASHER, SPRING    | 2   |                 |
| 14      | 92995-06600-00  | WASHER            | 2   |                 |
| 15      | 97013-06014-00  | BOLT              | 4   |                 |
| 16      | 92903-06600-00  | WASHER, PLATE     | 4   |                 |
| 17      | 90464-15M11-00  | CLAMP             | 1   |                 |
| 18      | 90465-11M52-00  | CLAMP             | 1   |                 |
| 19      | 61A-85537-00-00 | COVER             | 1   |                 |

CONTINUED ON NEXT FRAME >



65J0010-9121

# ELECTRICAL 1

| Ref No. | Part Number     | Description        | Qty | Remarks |
|---------|-----------------|--------------------|-----|---------|
| 20      | 90159-06M03-00  | SCREW, WITH WASHER | 4   |         |
| 21      | 61A-82519-00-00 | WIRE, EARTH LEAD   | 1   |         |
| 22      | 6G0-82519-00-00 | WIRE, EARTH LEAD   | 1   |         |
| 23      | 97095-06012-00  | BOLT               | 2   |         |
| 24      | 92995-06600-00  | WASHER             | 2   |         |

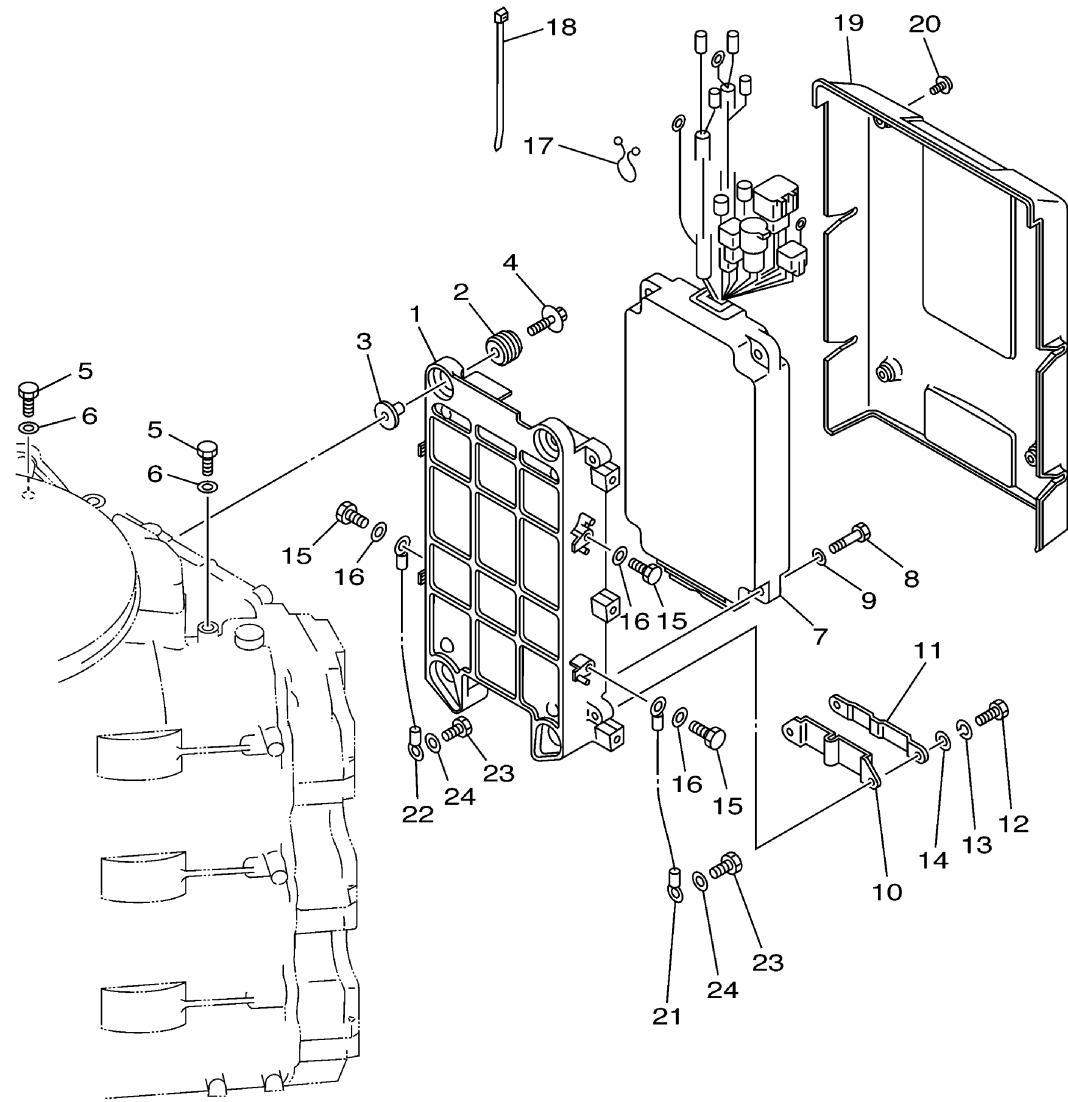

65J0010-9121