

LOWER CASING DRIVE 1 SX

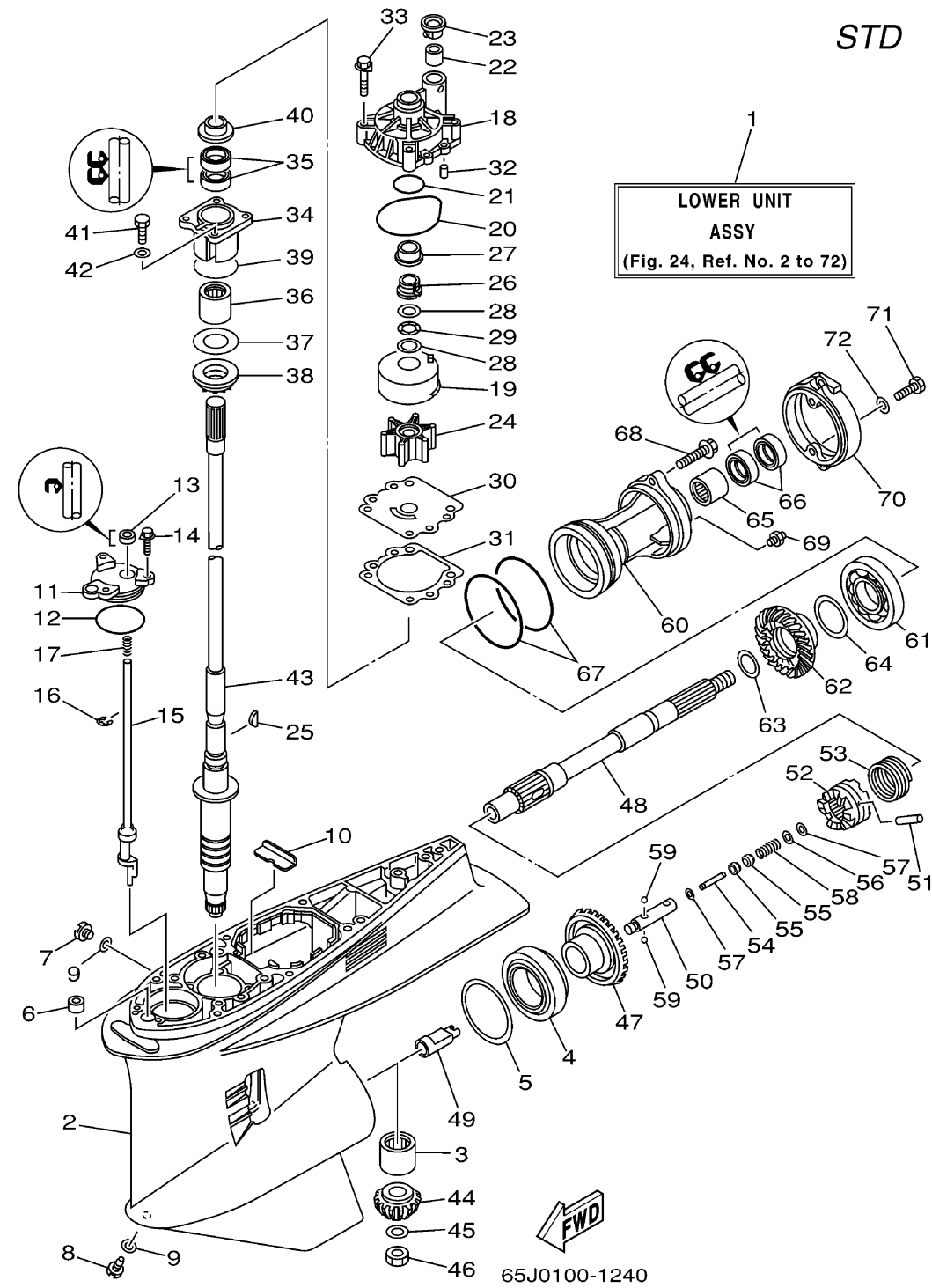

Ref No.	Part Number	Description	Qty	Remarks
1	65J-45300-31-8D	LOWER UNIT ASSY	1	UR U
1	65J-45300-21-8D	LOWER UNIT ASSY	1	UR X
2	61A-45301-10-8D	CASING, LOWER	1	
3	93311-832V2-00	BEARING	1	
4	93332-000W1-00	BEARING	1	
5	61A-45567-00-12	SHIM (T:0.12MM)	1	UR
5	61A-45567-00-10	SHIM (T:0.10MM)	1	UR
5	61A-45567-00-15	SHIM (T:0.15MM)	1	UR
5	61A-45567-00-50	SHIM (T:0.50MM)	1	UR
5	61A-45567-00-40	SHIM (T:0.40MM)	1	UR
5	61A-45567-00-18	SHIM (T:0.18MM)	1	UR
5	61A-45567-00-30	SHIM (T:0.30MM)	1	UR
6	663-44366-00-00	DAMPER, WATER SEAL 2	1	
7	90340-08002-00	PLUG, STRAIGHT SCREW	1	
8	688-45341-10-00	PLUG, DRAIN	1	
9	90430-08020-00	.GASKET	2	
10	61A-45376-00-94	GUIDE, SEAL DAMPER	1	
11	61A-45321-01-00	PLATE	1	
12	93210-64488-00	.O-RING	1	
13	93106-09014-00	.OIL SEAL	1	

CONTINUED ON NEXT FRAME >

LOWER CASING DRIVE 1 SX

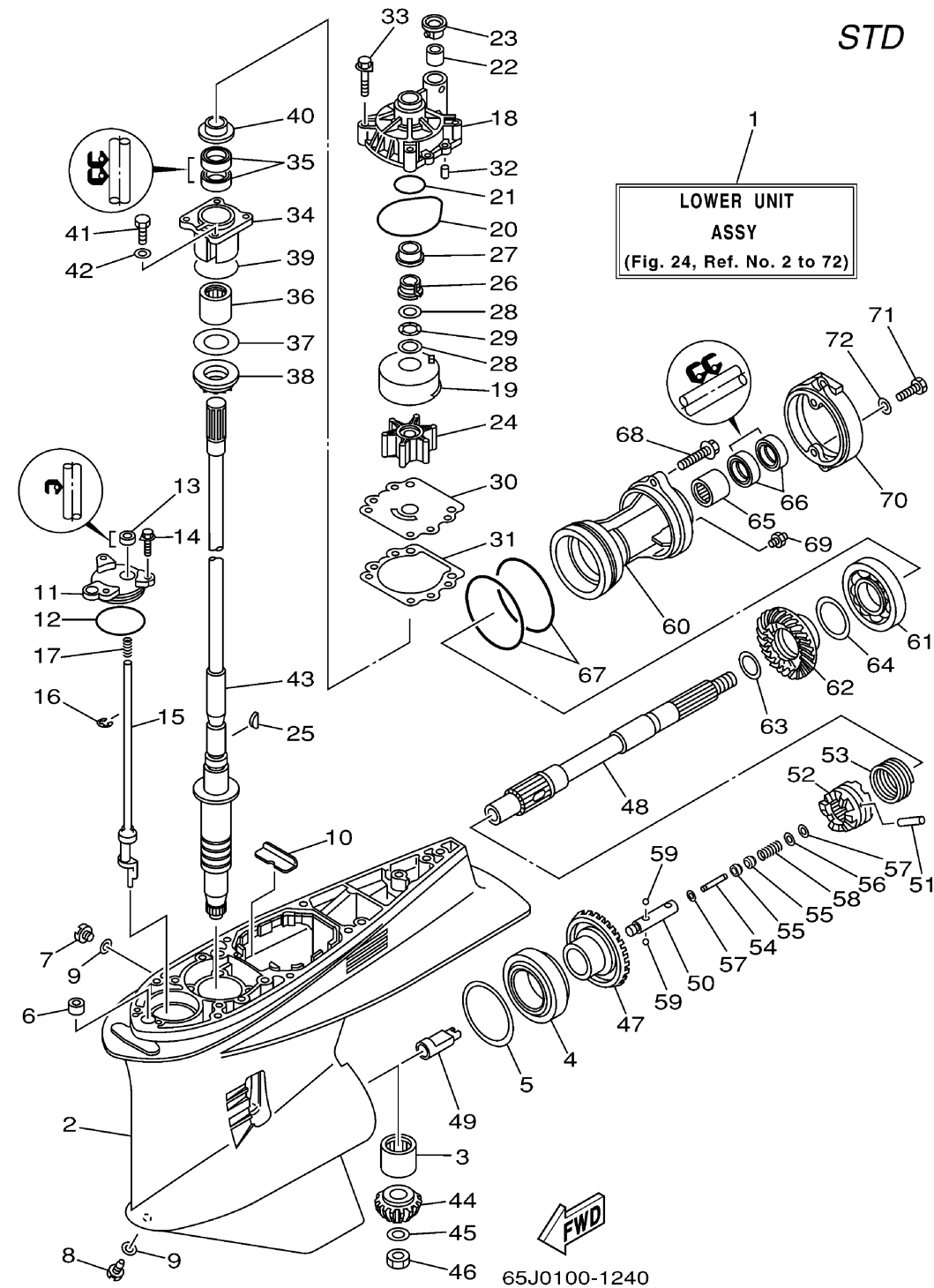

Ref No.	Part Number	Description	Qty	Remarks
14	90119-06M10-00	BOLT, WITH WASHER	3	
15	60V-44150-00-00	SHIFT CAM ASSY	1	
16	99001-08600-00	CIRCLIP	1	
17	90501-11M10-00	SPRING, COMPRESSION	1	
18	61A-44311-01-00	HOUSING, WATER PUMP	1	
19	61A-44322-02-00	.INSERT, CARTRIDGE	1	
20	93210-86M38-00	.O-RING	1	
21	93210-37160-00	.O-RING	1	
22	6E5-44365-00-00	.DAMPER, WATER SEAL 1	1	
23	6E5-44312-00-00	COVER, WATER PUMP HOUSING	1	
24	6E5-44352-01-00	.IMPELLER	1	
25	90280-04M05-00	.KEY, WOODRUFF	1	
26	61A-45538-00-00	SPACER 1	1	
27	61A-45527-00-00	COLLAR, DRIVE SHAFT	1	
28	90201-22M01-00	WASHER, PLATE	2	
29	90206-22M19-00	WASHER, WAVE	1	
30	6G5-44323-00-00	.OUTER PLATE, CARTRIDGE	1	
31	6E5-44315-A0-00	.GASKET, WATER PUMP	1	
32	93606-12019-00	PIN, DOWEL	2	
33	90119-08M14-00	.BOLT, WITH WASHER	4	

CONTINUED ON NEXT FRAME >

LOWER CASING DRIVE 1 SX

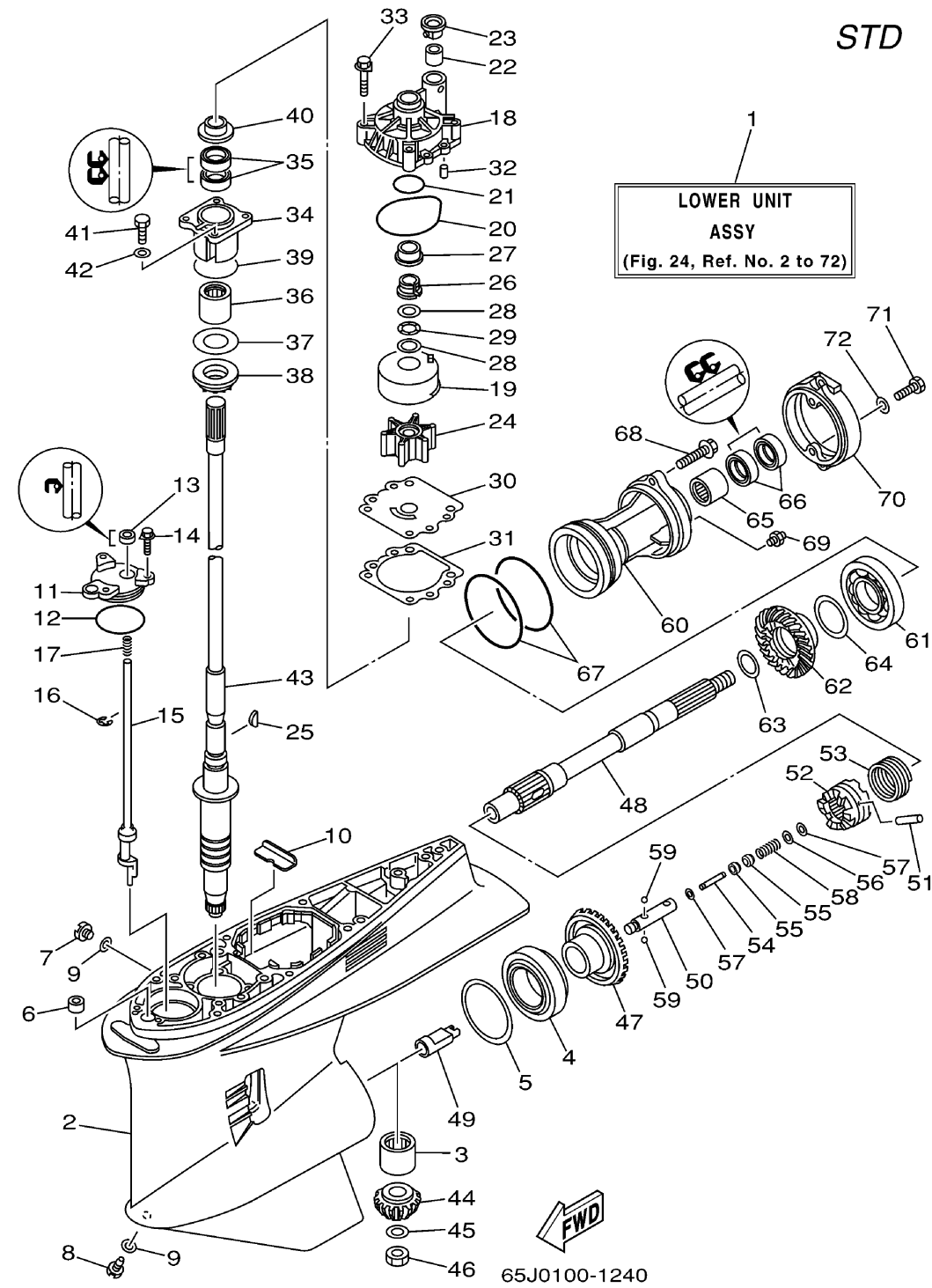

Ref No.	Part Number	Description	Qty	Remarks
34	61A-45331-00-94	HOUSING, BEARING	1	
35	93101-28M16-00	.OIL SEAL	2	
36	93317-330U2-00	BEARING	1	
37	61A-45587-00-10	SHIM (T:0.10MM)	1	UR
37	61A-45587-00-12	SHIM (T:0.12MM)	1	UR
37	61A-45587-00-15	SHIM (T:0.15MM)	1	UR
37	61A-45587-00-18	SHIM (T:0.18MM)	1	UR
37	61A-45587-00-30	SHIM (T:0.30MM)	1	UR
37	61A-45587-00-40	SHIM (T:0.40MM)	1	UR
37	61A-45587-00-50	SHIM (T:0.50MM)	1	UR
38	93341-930U9-00	BEARING	1	
39	93210-55M14-00	.O-RING	1	
40	6E5-45344-00-00	COVER, OIL SEAL	1	
41	97095-08025-00	BOLT	4	
42	92995-08600-00	WASHER	4	
43	61A-45501-20-00	DRIVE SHAFT COMP.	1	UR X
43	61A-45501-30-00	DRIVE SHAFT COMP.	1	UR U
44	61A-45551-03-00	PINION (16T)	1	
45	90201-16M00-00	WASHER, PLATE	1	
46	90170-16M19-00	NUT	1	

CONTINUED ON NEXT FRAME >

LOWER CASING DRIVE 1 SX

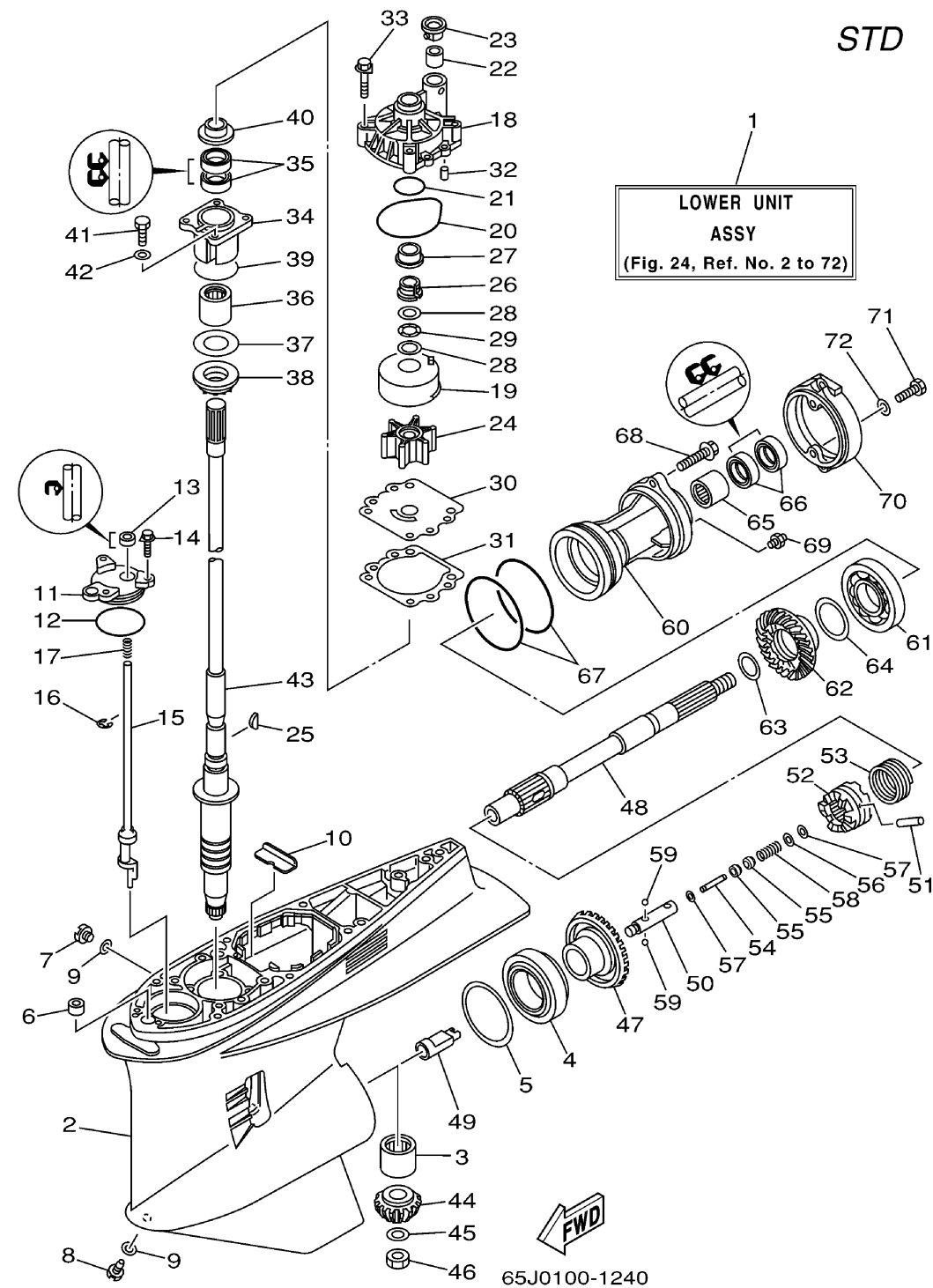

Ref No.	Part Number	Description	Qty	Remarks
47	61A-45560-03-00	GEAR 1 (29T)	1	
48	69J-45611-00-00	SHAFT, PROPELLER	1	
49	61A-45641-02-00	SHIFTER	1	
50	61A-45634-01-00	SLIDE, SHIFT	1	
51	61A-45632-00-00	PIN, CROSS	1	
52	61A-45631-03-00	CLUTCH, DOG	1	
53	61A-45633-00-00	RING, CROSS PIN	1	
54	6H1-45668-00-00	SHAFT, FREE 1	1	
55	61A-45635-00-00	PLUNGER, SHIFT	2	
56	90201-02M00-00	WASHER, PLATE	1	
57	90183-02M03-00	NUT, SPRING	2	
58	90501-10M77-00	SPRING, COMPRESSION	1	
59	93501-04011-00	BALL	2	
60	61A-45332-02-94	HOUSING, BEARING	1	
61	93306-210U0-00	BEARING	1	
62	61A-45571-00-00	GEAR 2 (29T)	1	
63	90201-31M00-00	WASHER, PLATE	1	
64	61A-45577-00-10	SHIM (T:0.10MM)	1	UR
64	61A-45577-00-12	SHIM (T:0.12MM)	1	UR
64	61A-45577-00-15	SHIM (T:0.15MM)	1	UR

CONTINUED ON NEXT FRAME >

LOWER CASING DRIVE 1 SX

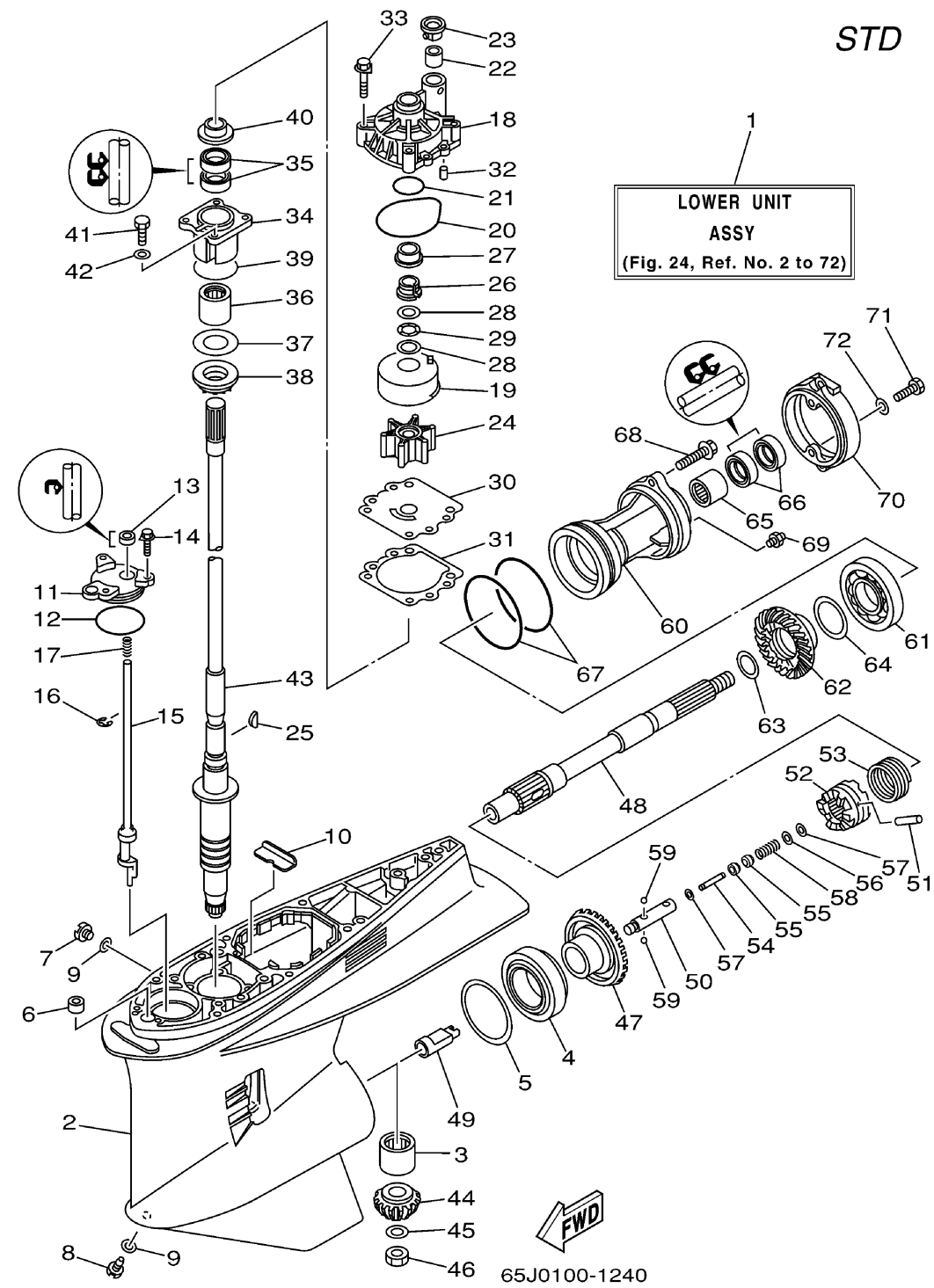

Ref No.	Part Number	Description	Qty	Remarks
64	61A-45577-00-18	SHIM (T:0.18MM)	1	UR
64	61A-45577-00-30	SHIM (T:0.30MM)	1	UR
64	61A-45577-00-40	SHIM (T:0.40MM)	1	UR
64	61A-45577-00-50	SHIM (T:0.50MM)	1	UR
65	93317-330U5-00	BEARING	1	
66	93101-30M17-00	.OIL SEAL	2	
67	93211-04384-00	.O-RING	2	
68	90105-08M48-00	BOLT, FLANGE	2	
69	93700-09M00-00	NIPPLE, GREASE	1	
70	61A-45361-01-5B	CAP, LOWER CASING	1	
71	97095-08020-00	BOLT	2	
72	92995-08600-00	WASHER	2	