

ELECTRICAL 1

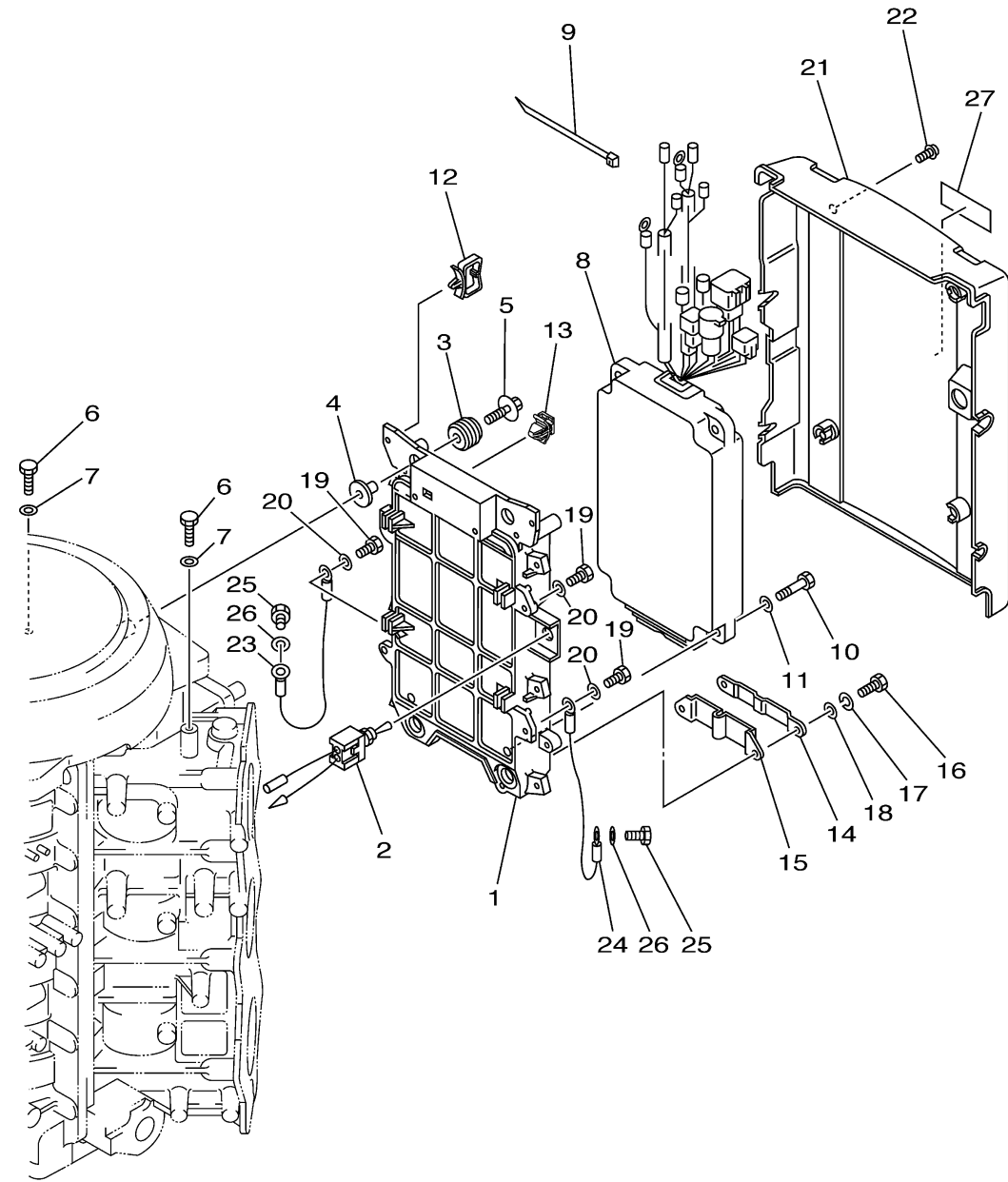

Ref No.	Part Number	Description	Qty	Remarks
1	67H-85542-00-94	BRACKET	1	
2	6R3-8259E-00-00	SWITCH ASSY	1	
3	90480-09M12-00	GROMMET	4	
4	90387-06M03-00	COLLAR	4	
5	90119-06M08-00	BOLT, WITH WASHER	4	
6	97095-06016-00	BOLT	2	
7	92990-06600-00	WASHER, PLATE	2	
8	67M-85540-01-00	C.D.I. UNIT ASSY	1	
9	90465-13M18-00	CLAMP	1	
10	97013-06025-00	BOLT	4	
11	92903-06600-00	WASHER, PLATE	4	
12	90464-23199-00	CLAMP	2	
13	90464-09M47-00	CLAMP	1	
14	61A-85525-00-00	COVER	1	
15	61A-85548-00-00	HOLDER	1	
16	97095-06016-00	BOLT	2	
17	92995-06100-00	WASHER, SPRING	2	
18	92995-06600-00	WASHER	2	
19	97095-06012-00	BOLT	4	
20	92990-06600-00	WASHER, PLATE	4	

CONTINUED ON NEXT FRAME >



67H1100-2130

ELECTRICAL 1

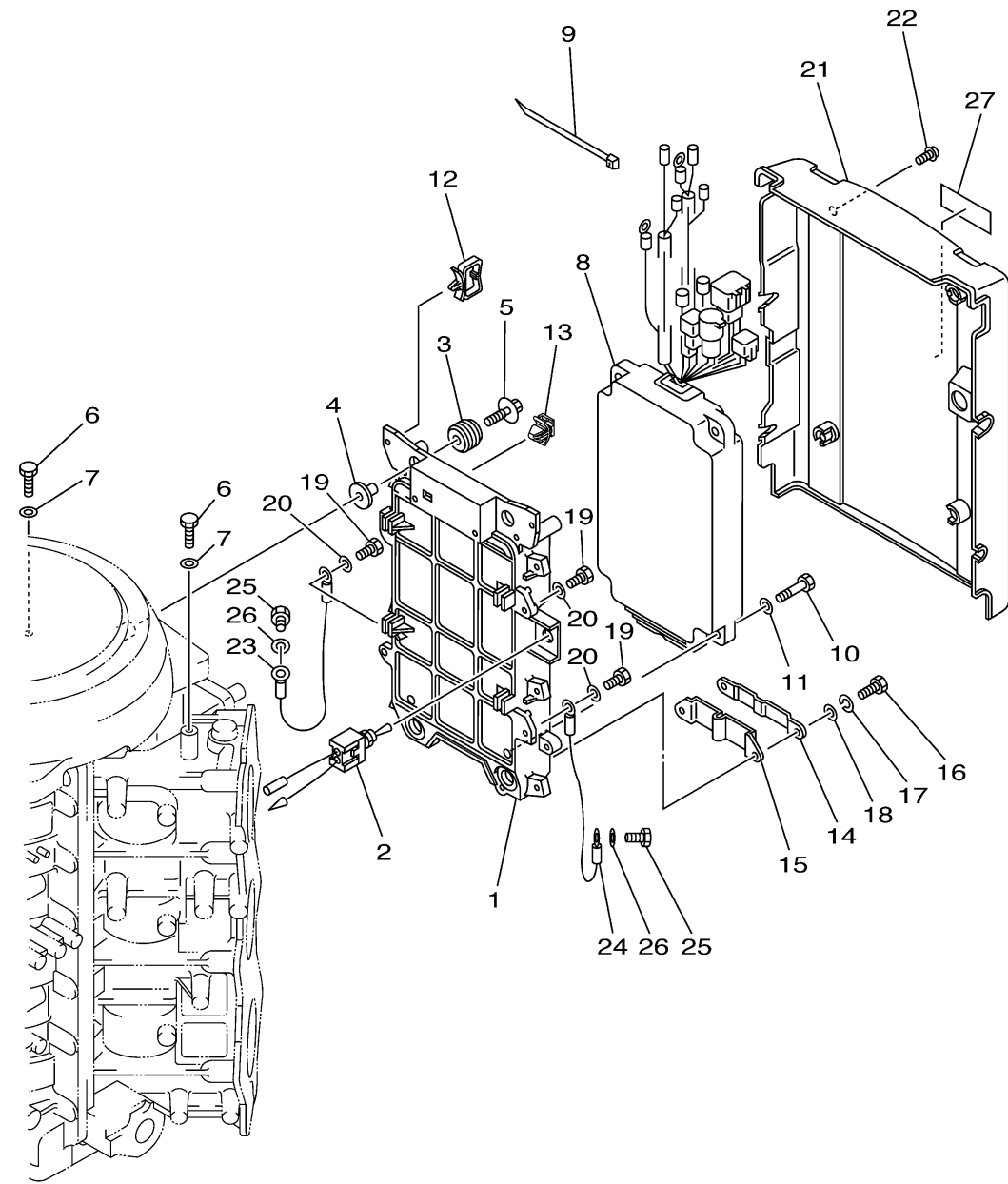

Ref No.	Part Number	Description	Qty	Remarks
21	67H-85537-00-00	COVER	1	
22	90159-06M03-00	SCREW, WITH WASHER	4	
23	61A-82519-00-00	WIRE, EARTH LEAD	1	
24	6R3-82519-00-00	WIRE, EARTH LEAD	1	
25	97080-06012-00	BOLT	2	
26	92995-06600-00	WASHER	2	
27	6E5-85711-40-00	MARK, CAUTION	1	



67H1100-2130