

LOWER CASING DRIVE 1

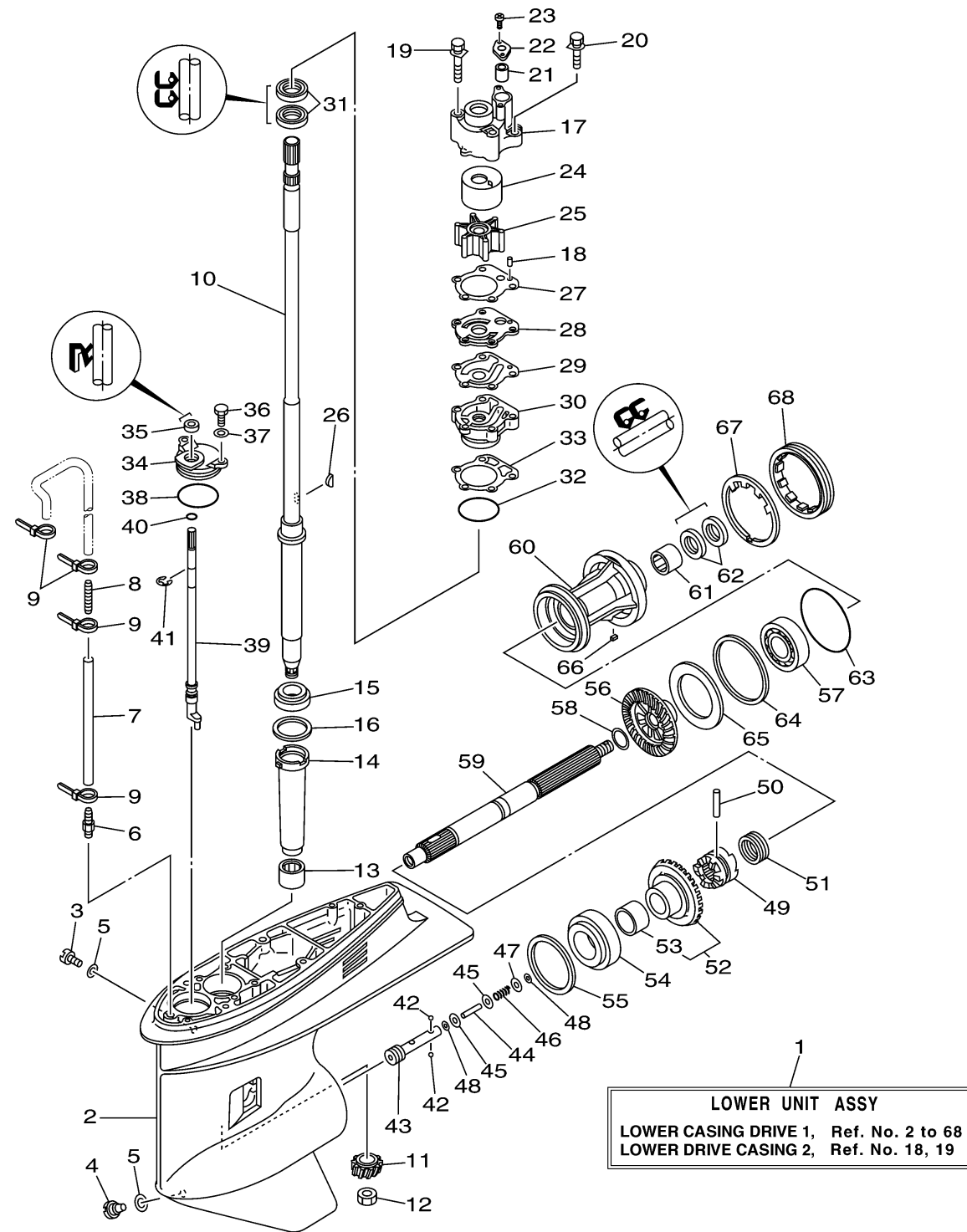

Ref No.	Part Number	Description	Qty	Remarks
1	6D8-45300-10-4D	LOWER UNIT ASSY	1	L
2	67F-45301-00-4D	CASING, LOWER	1	
3	90340-08002-00	PLUG, STRAIGHT SCREW	1	
4	688-45341-10-00	PLUG, DRAIN	1	
5	90430-08020-00	.GASKET	2	
6	6E5-45378-00-00	NIPPLE, HOSE	1	
7	90445-07M31-00	HOSE (L200)	1	L
8	6E5-83558-10-00	END, NIPPLE	1	
9	90465-11M10-00	CLAMP	4	
10	67F-45501-10-00	DRIVE SHAFT COMP.	1	L
11	67F-45551-00-00	PINION (13T)	1	
12	90170-16M01-00	NUT	1	
13	93315-325W4-00	BEARING	1	
14	688-45536-01-00	SLEEVE, DRIVE SHAFT	1	
15	93332-000U3-00	BEARING	1	
16	688-45587-01-00	SHIM (T:0.10MM)	1	UR
16	688-45587-10-00	SHIM (T:0.12MM)	1	UR
16	688-45587-20-00	SHIM (T:0.15MM)	1	UR
16	688-45587-30-00	SHIM (T:0.18MM)	1	UR
16	688-45587-40-00	SHIM (T:0.30MM)	1	UR

CONTINUED ON NEXT FRAME >



6D81100-D310

f75tlrd

F5

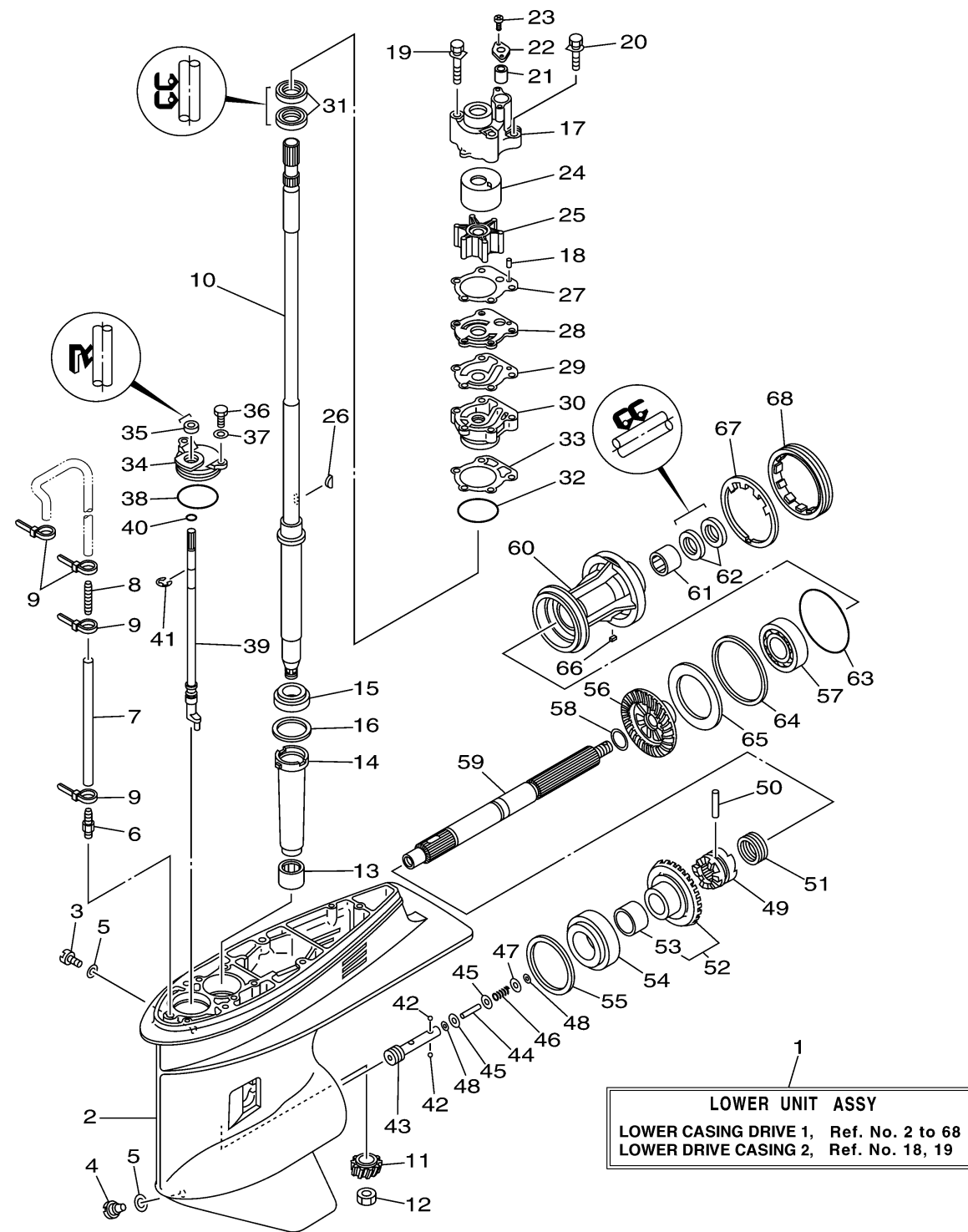

LOWER CASING DRIVE 1

Ref No.	Part Number	Description	Qty	Remarks
16	688-45587-50-00	SHIM (T:0.40MM)	1	UR
16	688-45587-60-00	SHIM (T:0.50MM)	1	UR
17	67F-44311-00-00	HOUSING, WATER PUMP	1	
18	93604-10M03-00	.PIN, DOWEL	2	
19	90119-08M87-00	.BOLT, WITH WASHER	2	
20	90119-08M13-00	.BOLT, WITH WASHER	2	
21	663-44366-00-00	DAMPER, WATER SEAL 2	1	
22	90480-19M06-00	GROMMET	1	
23	97780-40512-00	SCREW, TAPPING	2	
24	67F-44322-00-00	.INSERT, CARTRIDGE	1	
25	67F-44352-00-00	.IMPELLER	1	
26	90280-04M04-00	.KEY, WOODRUFF	1	
27	688-44315-A0-00	.GASKET, WATER PUMP	1	
28	67F-44323-00-00	.OUTER PLATE, CARTRIDGE	1	
29	688-44324-A0-00	.GASKET, CARTRIDGE	1	
30	6D8-44341-00-00	HOUSING, WATER PUMP	1	
31	93101-25M03-00	.OIL SEAL	2	
32	93210-46044-00	O-RING	1	
33	688-44316-A0-00	.GASKET, WATER PUMP	1	
34	688-45321-00-00	PLATE	1	

CONTINUED ON NEXT FRAME >



6D81100-D310

f75tlrd

F6

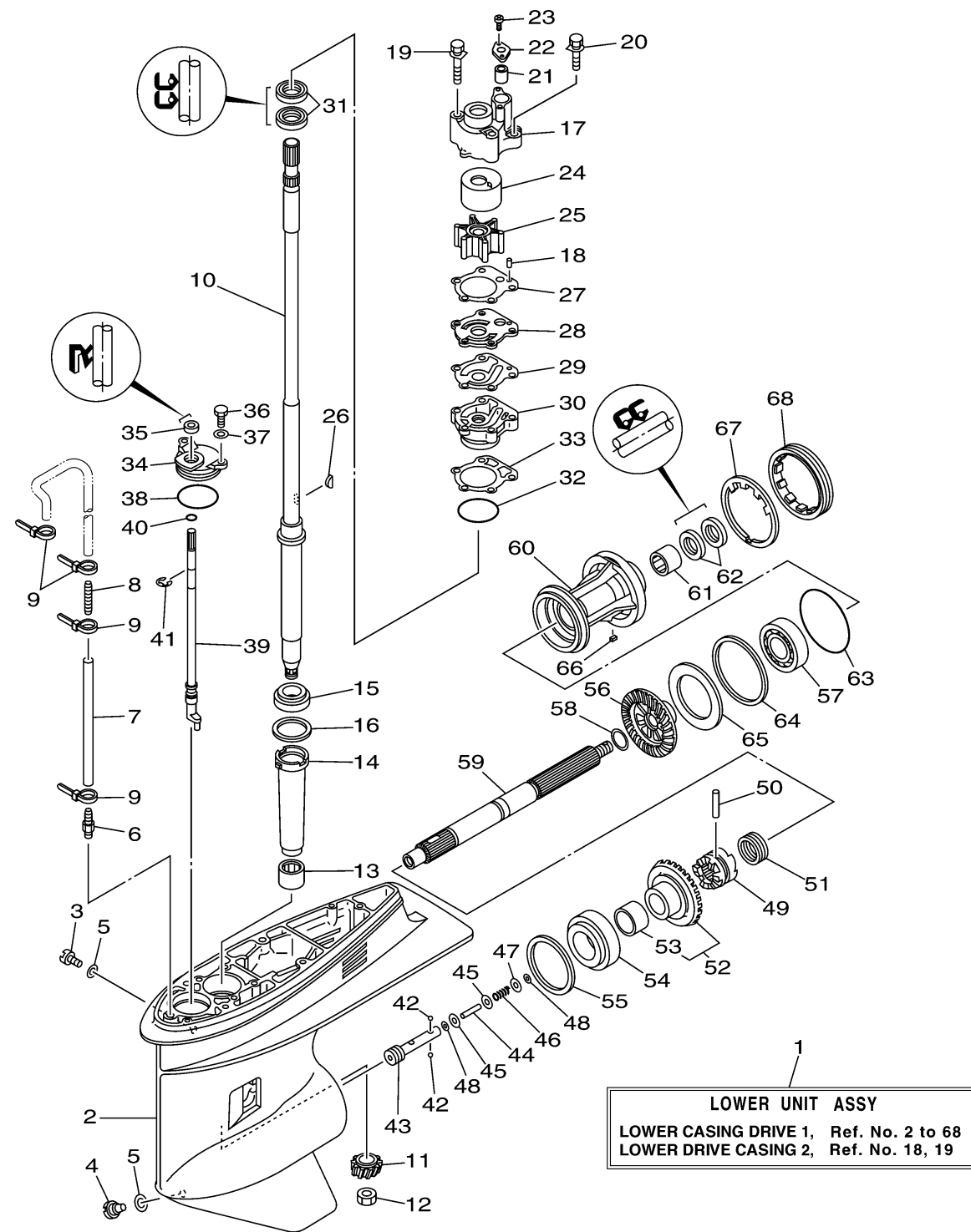

LOWER CASING DRIVE 1

Ref No.	Part Number	Description	Qty	Remarks
35	93106-09014-00	.OIL SEAL	1	
36	97095-06016-00	BOLT	2	
37	92995-06600-00	WASHER	2	
38	93210-49046-00	O-RING	1	
39	67F-44150-00-00	SHIFT CAM ASSY	1	
40	93210-07003-00	O-RING	1	
41	99001-08600-00	CIRCLIP	1	
42	93503-16003-00	BALL	2	
43	67F-45634-00-00	SLIDE, SHIFT	1	
44	6H1-45668-00-00	SHAFT, FREE 1	1	
45	6H1-45635-00-00	PLUNGER, SHIFT	2	
46	90501-12M48-00	SPRING, COMPRESSION	1	
47	90201-03313-00	WASHER, PLATE	1	
48	90183-02M03-00	NUT, SPRING	2	
49	67F-45631-00-00	CLUTCH, DOG	1	
50	90250-07M02-00	PIN, STRAIGHT	1	
51	688-45633-00-00	RING, CROSS PIN	1	
52	67F-45560-00-00	GEAR 1 (30T)	1	
53	93317-322V0-00	. .BEARING	1	
54	93332-000UD-00	BEARING	1	

CONTINUED ON NEXT FRAME >

LOWER CASING DRIVE 1

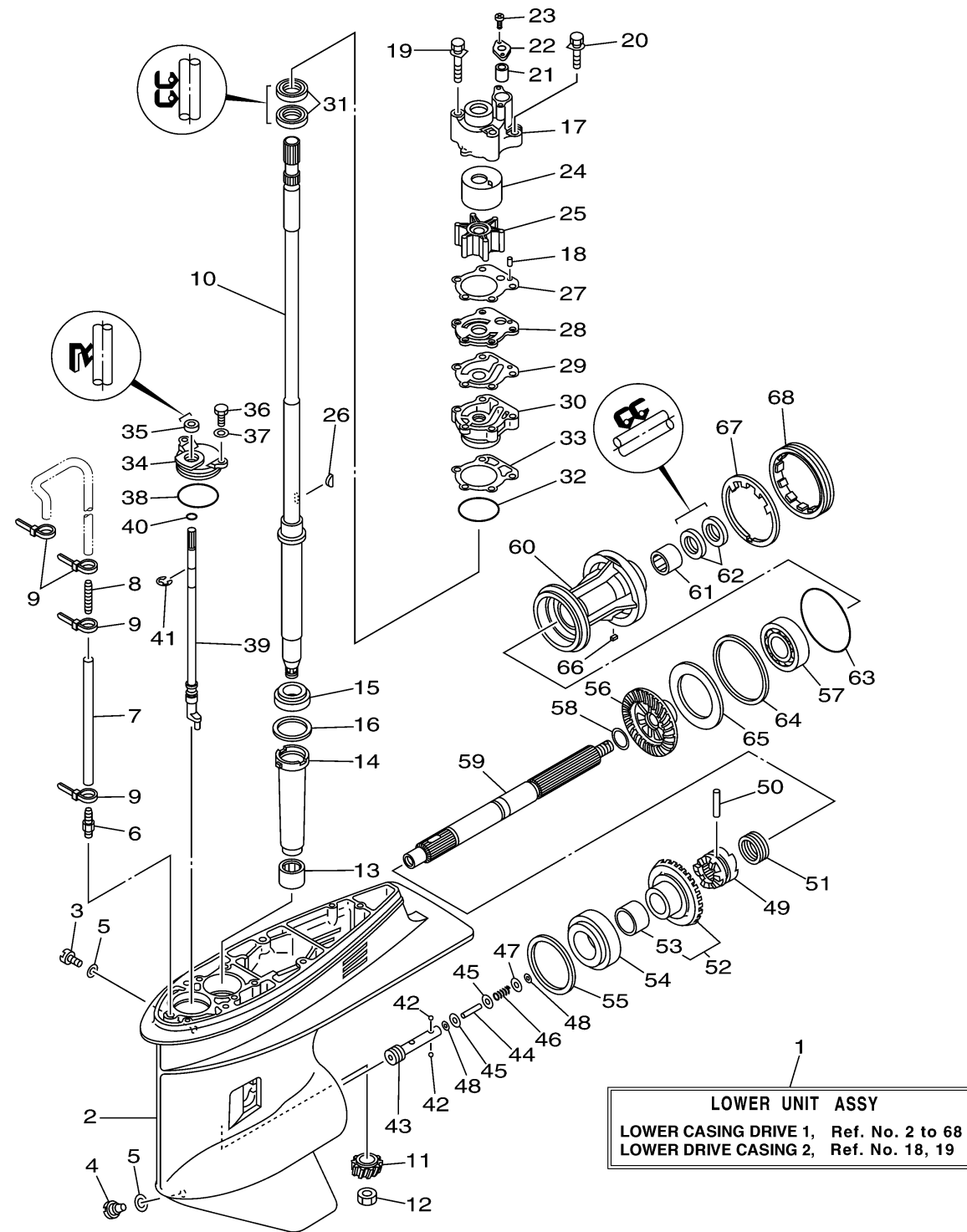

Ref No.	Part Number	Description	Qty	Remarks
55	688-45567-01-00	SHIM (T:0.10MM)	1	UR
55	688-45567-10-00	SHIM (T:0.12MM)	1	UR
55	688-45567-20-00	SHIM (T:0.15MM)	1	UR
55	688-45567-30-00	SHIM (T:0.18MM)	1	UR
55	688-45567-40-00	SHIM (T:0.30MM)	1	UR
55	688-45567-50-00	SHIM (T:0.40MM)	1	UR
55	688-45567-60-00	SHIM (T:0.50MM)	1	UR
56	67F-45571-00-00	GEAR 2 (30T)	1	
57	93306-207U0-00	.BEARING	1	
58	90201-25M05-00	WASHER, PLATE	1	
59	67F-45611-01-00	SHAFT, PROPELLER	1	
60	67F-45331-00-94	HOUSING, BEARING	1	
61	93317-325U0-00	BEARING	1	
62	93101-25M03-00	.OIL SEAL	2	
63	93210-86M39-00	.O-RING	1	
64	6L6-45577-40-00	SHIM (T:0.30MM)	1	
65	67F-45576-00-00	WASHER, THRUST 2	1	
66	90282-04010-00	KEY, STRAIGHT	1	
67	688-45383-02-00	WASHER, CLAW	1	
68	688-45384-00-00	NUT	1	



6D81100-D310

f75tlrd

F8