

# ELECTRICAL 2

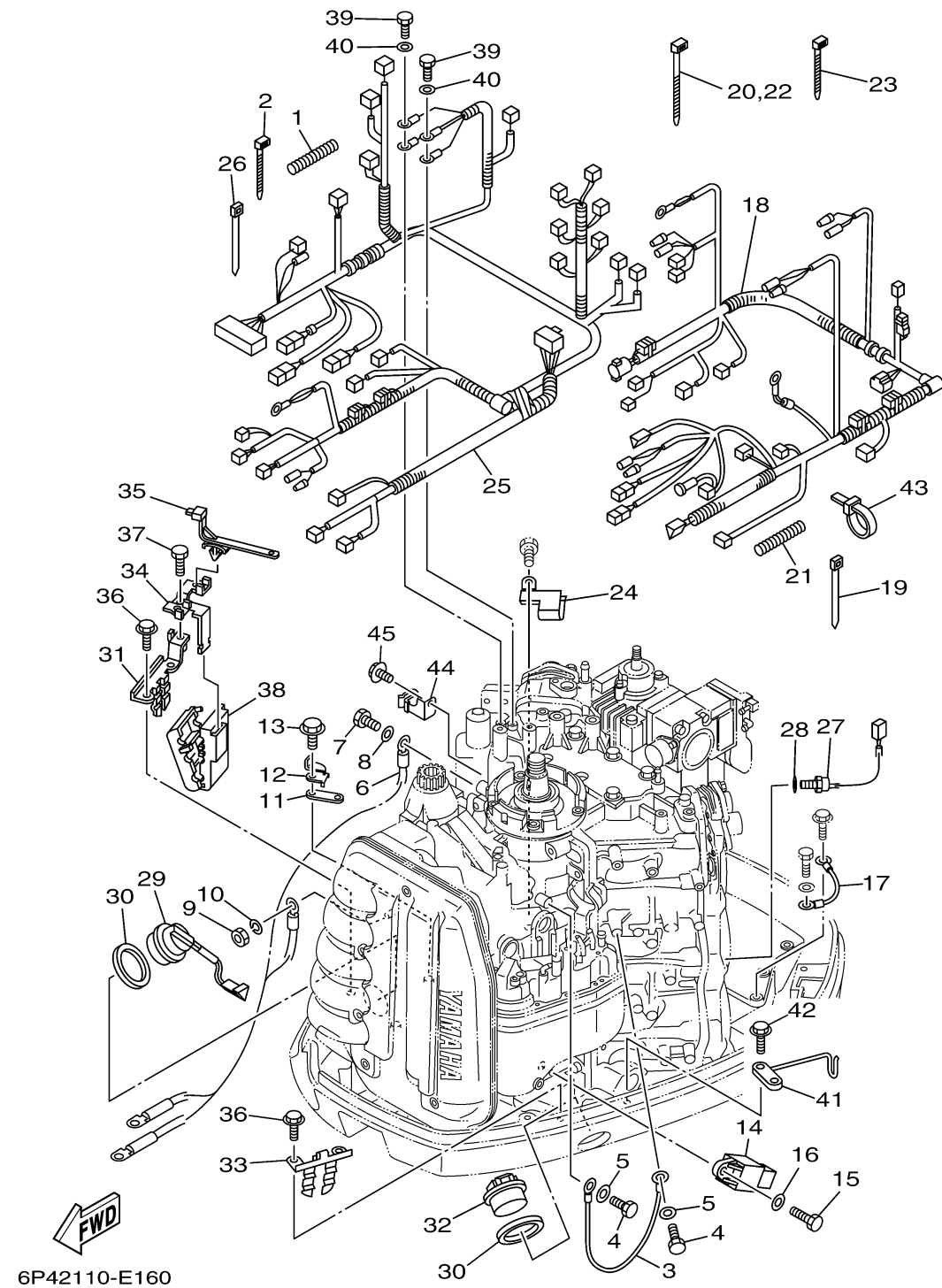

Ref No.	Part Number	Description	Qty	Remarks
1	90447-07011-00	TUBE	1	
2	90465-11M10-00	CLAMP	1	
3	6H2-81949-11-00	WIRE, LEAD	1	
4	97095-06012-00	BOLT	2	
5	92995-06600-00	WASHER	2	
6	68F-82105-00-00	BATTERY CABLE	1	
7	97095-08016-00	BOLT	1	
8	92995-08600-00	WASHER	1	
9	95333-08600-00	NUT	1	
10	92903-08100-00	WASHER, SPRING	1	
11	6E5-82588-00-00	PLATE	1	
12	68F-81845-00-00	PLATE	1	
13	95895-06020-00	BOLT, FLANGE	1	
14	68V-81950-00-00	RELAY ASSY	1	
15	97095-06016-00	BOLT	1	
16	92995-06600-00	WASHER	1	
17	6E5-82531-10-00	WIRE, LEAD	1	
18	68F-82590-A0-00	WIRE HARNESS ASSY	1	
19	90465-11M52-00	CLAMP	1	
20	90465-13M18-00	CLAMP	1	

CONTINUED ON NEXT FRAME >

# ELECTRICAL 2

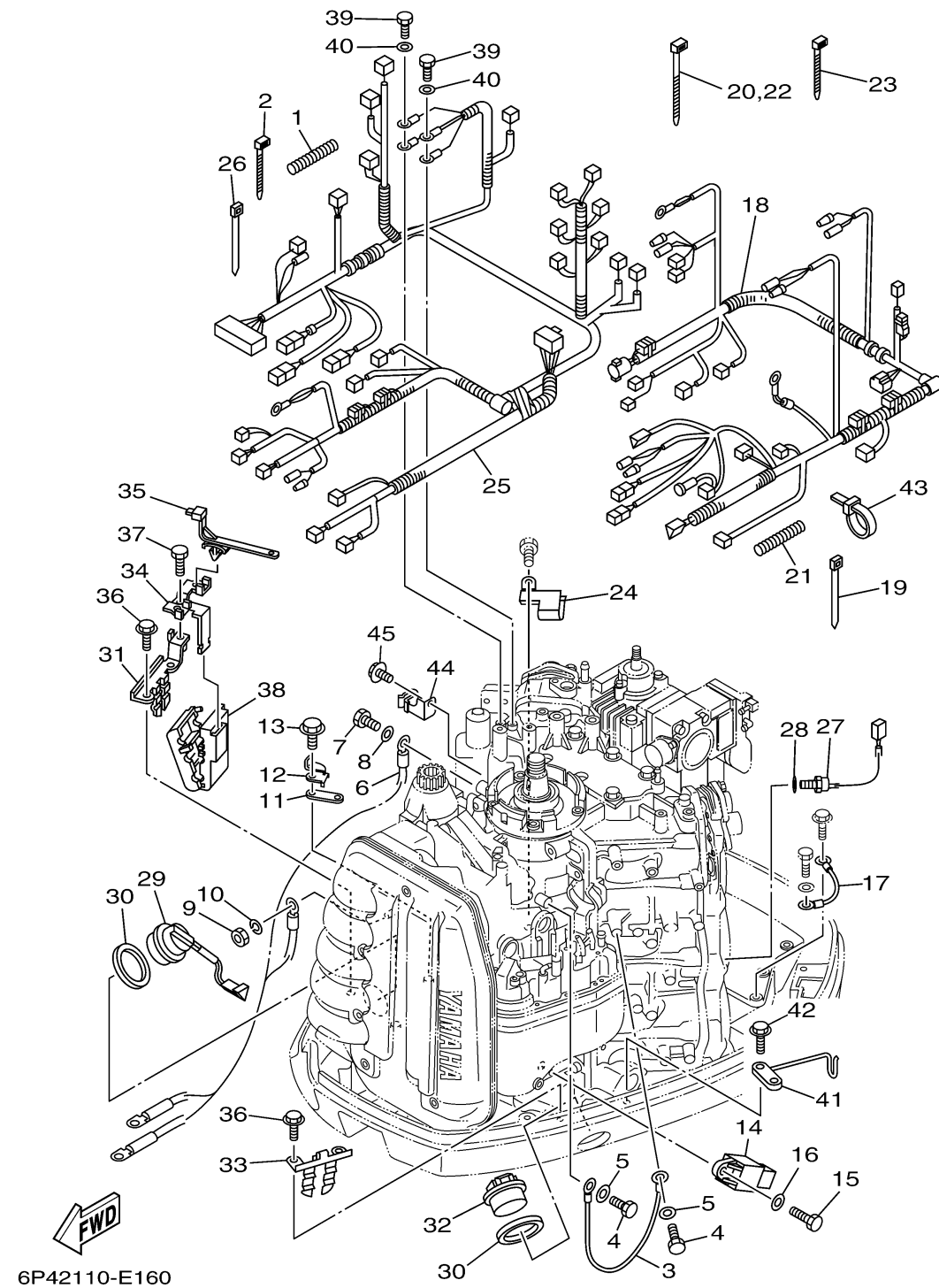

Ref No.	Part Number	Description	Qty	Remarks
21	68F-83557-00-00	TUBE	1	
22	90465-13M18-00	CLAMP	1	
23	90465-11M10-00	CLAMP	1	
24	68F-83919-00-00	CLAMP, HARNESS	1	
25	68F-8259M-80-00	WIRE HARNESS ASSY 2	1	
26	90465-11M52-00	CLAMP	1	
27	61A-85790-00-00	THERMOSENSOR ASSY	1	
28	92990-10600-00	WASHER, PLATE	1	
29	6R3-82563-00-00	TRIM & TILT SWITCH ASSY	1	
30	6E5-82587-00-00	GASKET	2	
31	68F-83614-00-00	BRACKET	1	
32	68F-42723-10-8D	COVER, BOTTOM	1	
33	68F-83614-10-00	BRACKET	1	
34	68F-83635-00-00	BRACKET	1	
35	90464-20213-00	CLAMP	2	
36	90109-06M80-00	BOLT	4	
37	97095-06014-00	BOLT	1	
38	68F-83634-00-00	GROMMET	1	
39	97095-06014-00	BOLT	2	
40	92995-06600-00	WASHER	2	

CONTINUED ON NEXT FRAME >

## ELECTRICAL 2

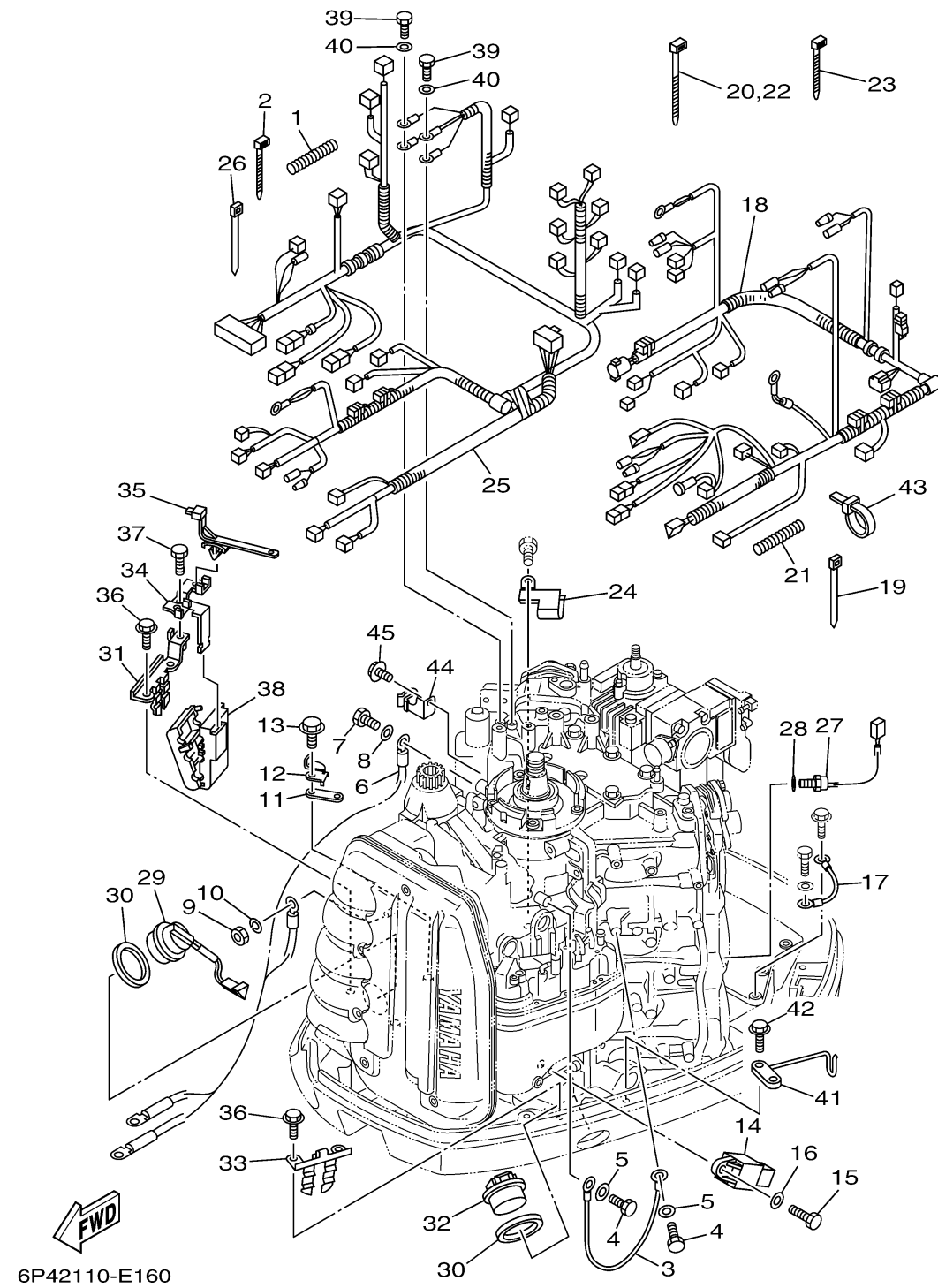

Ref No.	Part Number	Description	Qty	Remarks
41	6K7-82588-00-00	PLATE	1	
42	95895-06020-00	BOLT, FLANGE	1	
43	90464-11008-00	CLAMP	1	
44	90462-10033-00	CLAMP	1	
45	97595-06510-00	BOLT, WITH WASHER	1	