

OIL PAN

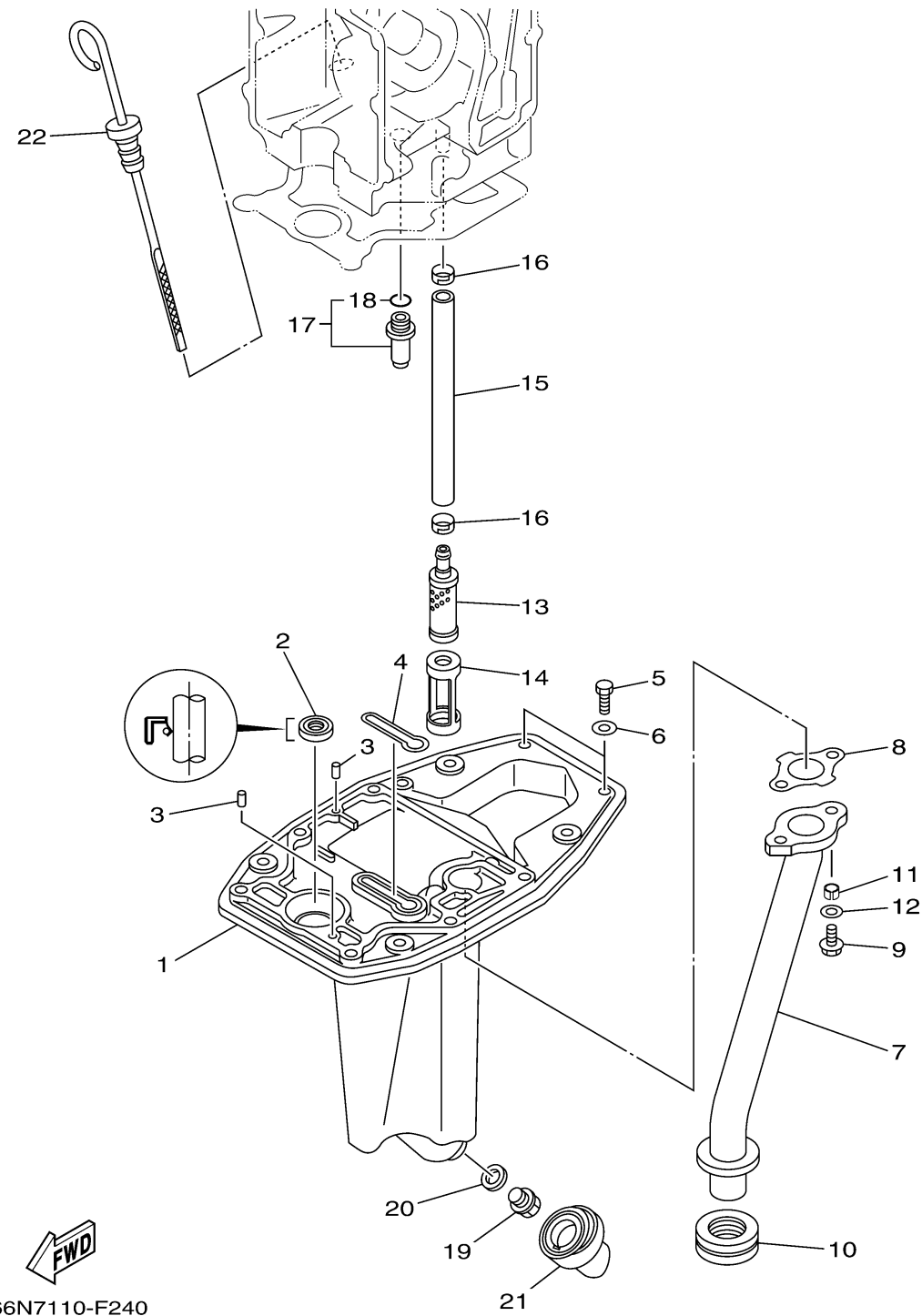

Ref No.	Part Number	Description	Qty	Remarks
1	66M-41137-00-5B	GUIDE, EXHAUST	1	
2	93101-12M63-00	.OIL SEAL	1	
3	93606-12019-00	PIN, DOWEL	2	
4	66M-11355-00-00	SEAL, CYLINDER 1	1	
5	97095-06020-00	BOLT	2	
6	92995-06600-00	WASHER	2	
7	6D4-41131-00-94	MANIFOLD, EXT. 1	1	
8	66M-41133-01-00	.GASKET, EXHAUST MANIFOLD 1	1	
9	90119-06090-00	BOLT, WITH WASHER	2	
10	6D4-41138-00-00	.SEAL, EXT. 1	1	
11	90387-05008-00	COLLAR	2	
12	90201-06015-00	WASHER, PLATE	2	
13	66M-13421-00-00	STRAINER 2	1	
14	66M-13417-00-00	COVER, STRAINER	1	
15	66M-13416-00-00	PIPE, OIL 1	1	
16	66M-24351-00-00	BAND 1	2	
17	6G8-11575-00-00	RELIEF VALVE ASSY	1	
18	93210-12M62-00	.O-RING	1	
19	90340-14M06-00	PLUG, STRAIGHT SCREW	1	
20	90430-14M09-00	.GASKET	1	

CONTINUED ON NEXT FRAME >

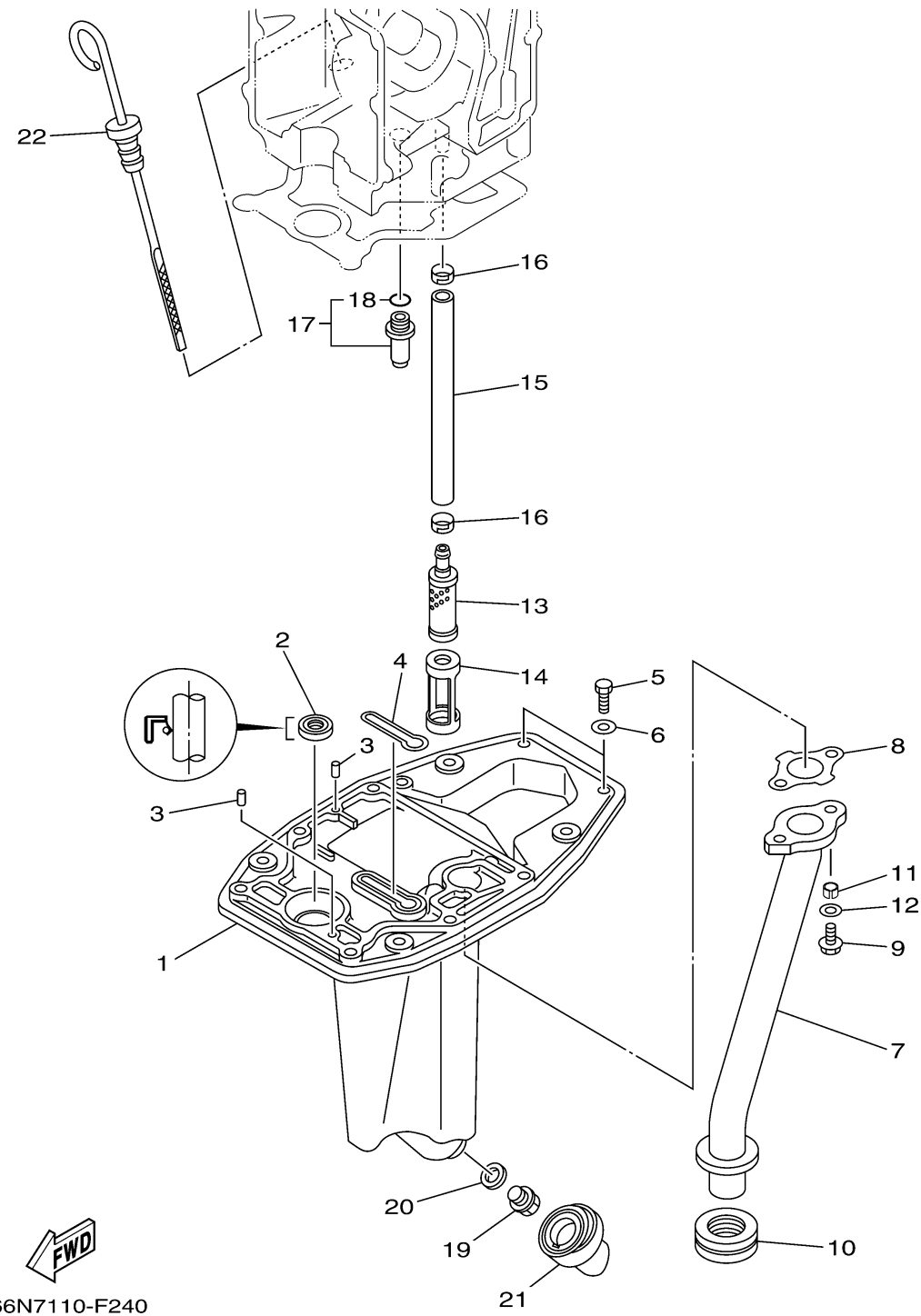

OIL PAN

Ref No.	Part Number	Description	Qty	Remarks
21	66M-15316-00-00	DAMPER, ENGINE MOUNT 1	1	
22	66M-15362-00-00	PLUG, OIL LEVEL	1	