

FWD
6P24100-G290

OIL PAN

Ref No.	Part Number	Description	Qty	Remarks
1	69J-15311-00-5B	OIL PAN	1	
2	69J-15761-00-00	SEAL, RUBBER 1	1	
3	97575-08560-00	BOLT, WITH WASHER	10	
4	97575-08535-00	BOLT, WITH WASHER	2	
5	93608-16M16-00	PIN, DOWEL	2	
6	90340-14M06-00	PLUG, STRAIGHT SCREW	1	
7	90430-14M09-00	.GASKET	1	
8	69J-13411-00-00	STRAINER, OIL	1	
9	90387-06M64-00	. COLLAR	3	
10	69J-13415-00-00	. .SEAL, OIL STRAINER	1	
11	97027-06025-00	BOLT, HEXAGON	3	
12	92907-06600-00	WASHER, PLATE	3	
13	69J-13300-01-00	OIL PUMP ASSY	1	
14	69J-13329-00-00	. .GASKET, PUMP COVER	1	
15	69J-13338-00-00	. .OIL SEAL	1	
16	69J-13119-00-00	. .OIL SEAL	1	
17	69J-13631-00-00	. .OIL SEAL	2	
18	69J-11355-00-00	.SEAL, CYLINDER 1	1	
19	97575-06540-00	BOLT, WITH WASHER	4	
20	93210-25552-00	O-RING	2	

CONTINUED ON NEXT FRAME >

OIL PAN

Ref No.	Part Number	Description	Qty	Remarks
21	6P2-15362-00-00	PLUG, OIL LEVEL	1	
22	6P2-15377-00-00	GUIDE, INLET	1	
23	93210-19MJ3-00	.O-RING	1	
24	97095-06020-00	BOLT	1	
25	92995-06100-00	WASHER, SPRING	1	
26	92995-06600-00	WASHER	1	

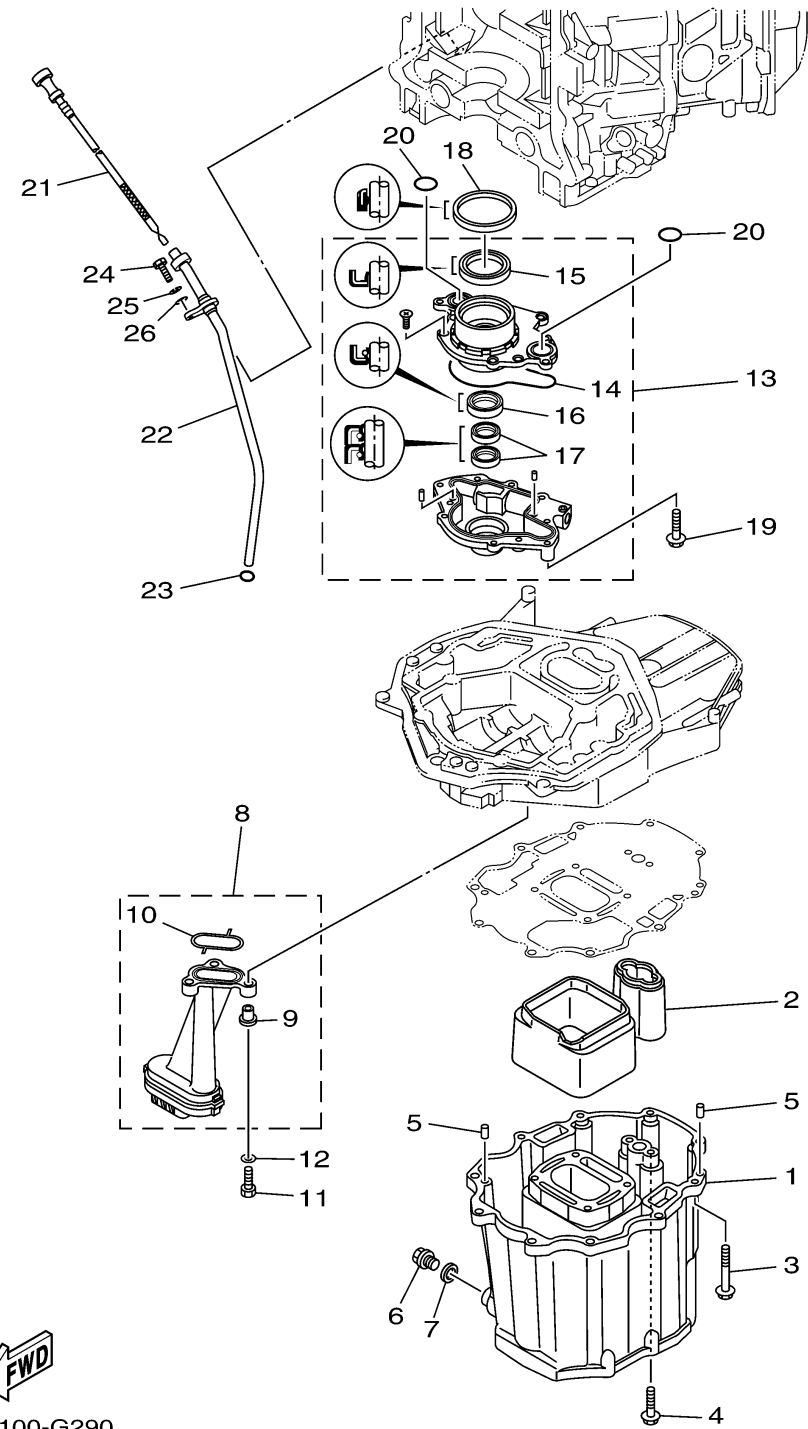

6P24100-G290