

CRANKSHAFT PISTON

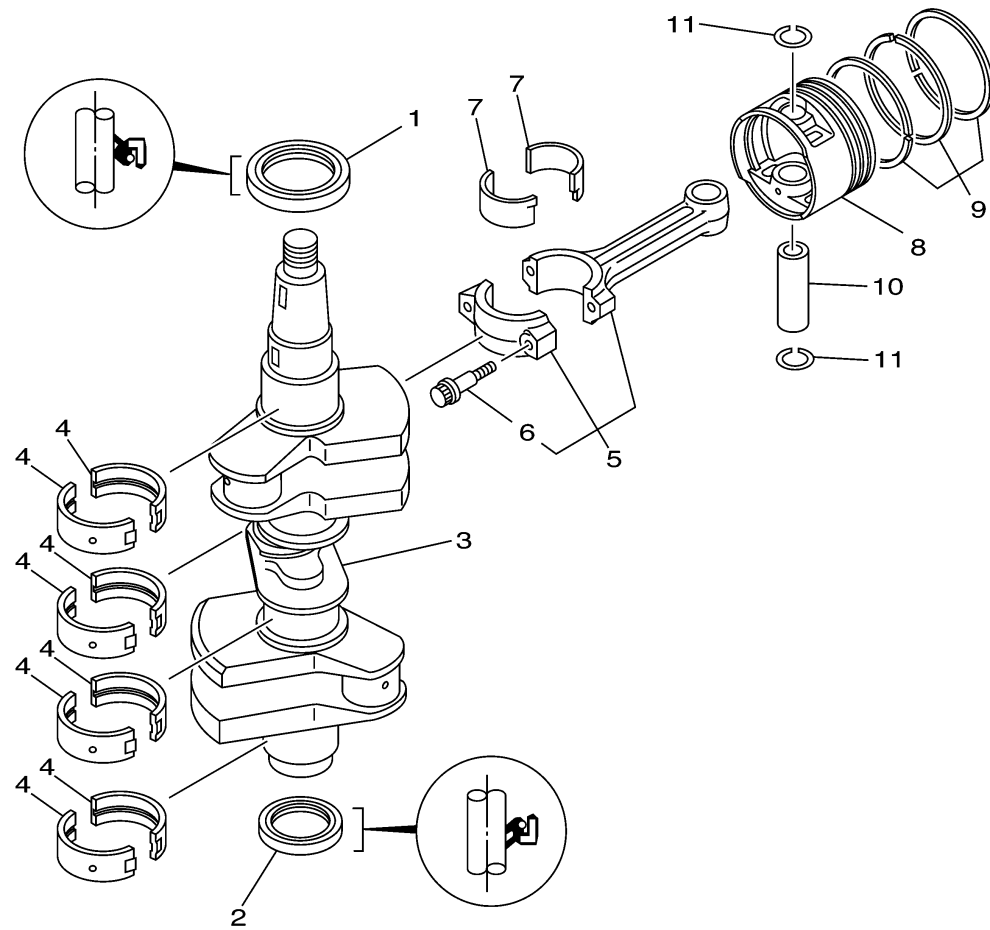

Ref No.	Part Number	Description	Qty	Remarks
1	93102-43M42-00	OIL SEAL	1	
2	93102-35M47-00	.OIL SEAL	1	
3	67C-11411-00-00	CRANKSHAFT	1	
4	62Y-11416-10-00	PLANE BEARING, CRANKSHAFT 1	8	UR BLACK
4	62Y-11416-20-00	PLANE BEARING, CRANKSHAFT 1	8	UR BLUE
4	62Y-11416-00-00	PLANE BEARING, CRANKSHAFT 1	8	UR BROWN
5	62Y-11650-10-00	CONNECTING ROD ASSY	3	
6	62Y-11654-00-00	.BOLT, CONNECTING ROD	2	
7	62Y-11656-20-00	PLANE BEARING, CONNECTING ROD	6	UR BLUE
7	62Y-11656-00-00	PLANE BEARING, CONNECTING ROD	6	UR BROWN
7	62Y-11656-10-00	PLANE BEARING, CONNECTING ROD	6	UR BLACK
8	65W-11631-00-96	PISTON (STD)	3	
8	65W-11636-00-00	PISTON (0.50MM O/S)	3	AP
8	65W-11635-00-00	PISTON (0.25MM O/S)	3	AP
9	67C-11605-00-00	PISTON RING SET (0.50MM O/S)	3	AP
9	67C-11604-00-00	PISTON RING SET (0.25MM O/S)	3	AP
9	67C-11603-00-00	PISTON RING SET (STD)	3	
10	62Y-11633-00-00	PIN, PISTON	3	
11	93450-17129-00	.CIRCLIP	6	



67C0010-0031