

OIL PAN

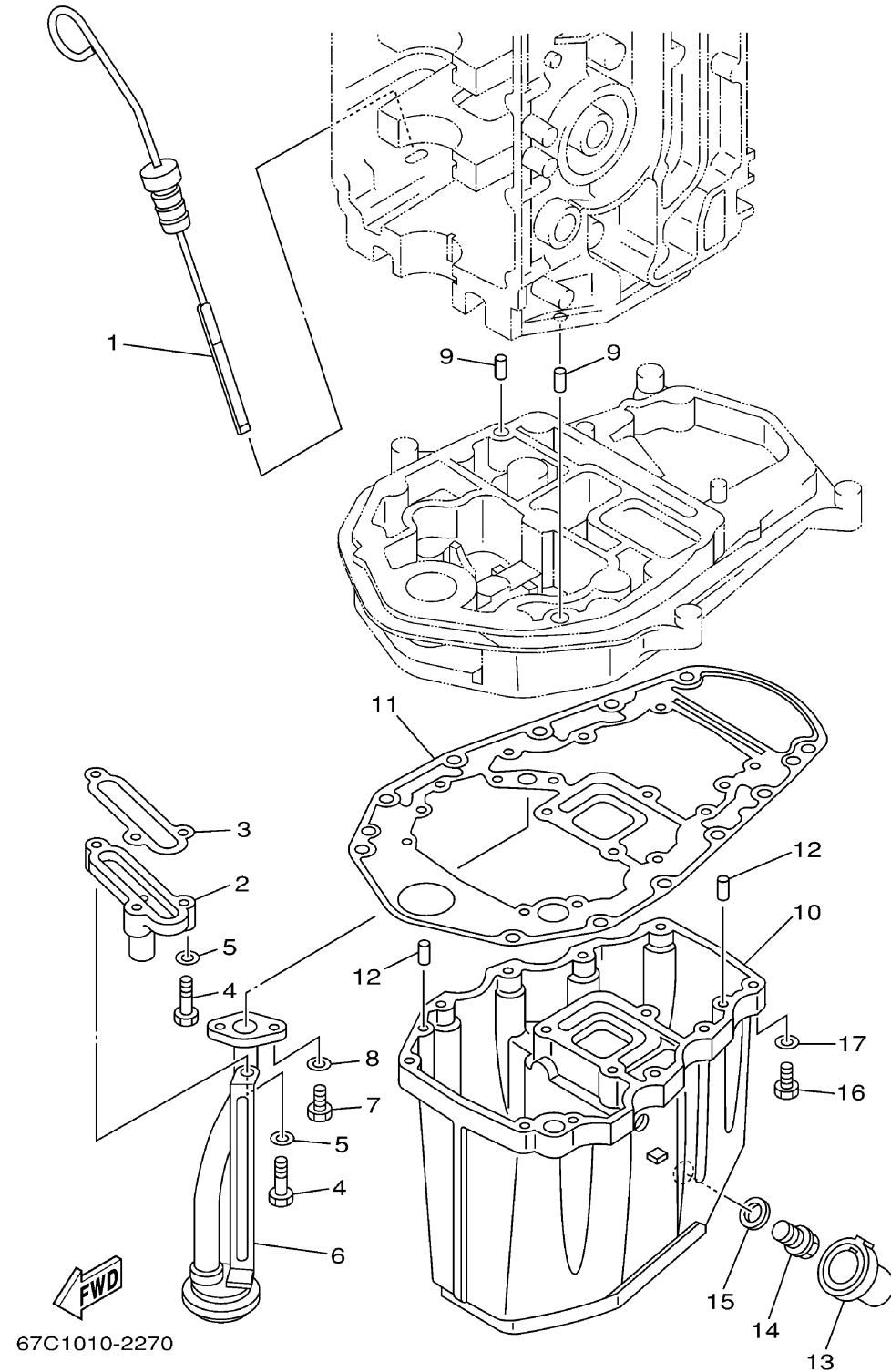

Ref No.	Part Number	Description	Qty	Remarks
1	67C-15362-00-00	PLUG, OIL LEVEL	1	
2	62Y-11575-00-00	RELIEF VALVE ASSY	1	
3	62Y-13475-00-00	.GASKET	1	
4	97013-06025-00	BOLT	3	
5	92903-06600-00	WASHER, PLATE	3	
6	62Y-13411-00-00	STRAINER, OIL	1	
7	97013-06016-00	BOLT	2	
8	92903-06600-00	WASHER, PLATE	2	
9	93608-12M05-00	PIN, DOWEL	2	
10	62Y-15311-02-5B	OIL PAN	1	
11	69W-15312-00-00	.GASKET, OIL PAN	1	
12	93606-12019-00	PIN, DOWEL	4	
13	67C-15316-00-00	DAMPER 1	1	L(21.0")
13	67C-15316-10-00	DAMPER 1	0	S(16.1")
14	90340-14M06-00	PLUG, STRAIGHT SCREW	1	
15	90430-14M09-00	GASKET	1	
16	97075-06025-00	BOLT	10	
17	92995-06600-00	WASHER	10	