

# OIL PAN

Ref No.	Part Number	Description	Qty	Remarks
1	6C5-15311-00-8D	OIL PAN	1	
2	6C5-15312-00-00	.GASKET, OIL PAN	1	
3	93606-12019-00	PIN, DOWEL	2	
4	6C5-15316-00-00	DAMPER 1	1	
5	90465-11M59-00	CLAMP	1	
6	90340-14M06-00	PLUG, STRAIGHT SCREW	1	
7	90430-14M09-00	.GASKET	1	
8	6C5-13411-00-00	STRAINER, OIL	1	
9	6C5-13414-00-00	GASKET, STRAINER COVER	1	
10	6C5-15333-00-00	COVER	1	
11	97013-06030-00	BOLT	6	
12	92903-06600-00	WASHER, PLATE	6	
13	6C5-15362-00-00	PLUG, OIL LEVEL	1	
14	6C5-45135-01-00	PIPE	1	
15	6C5-45136-01-00	PIPE	1	

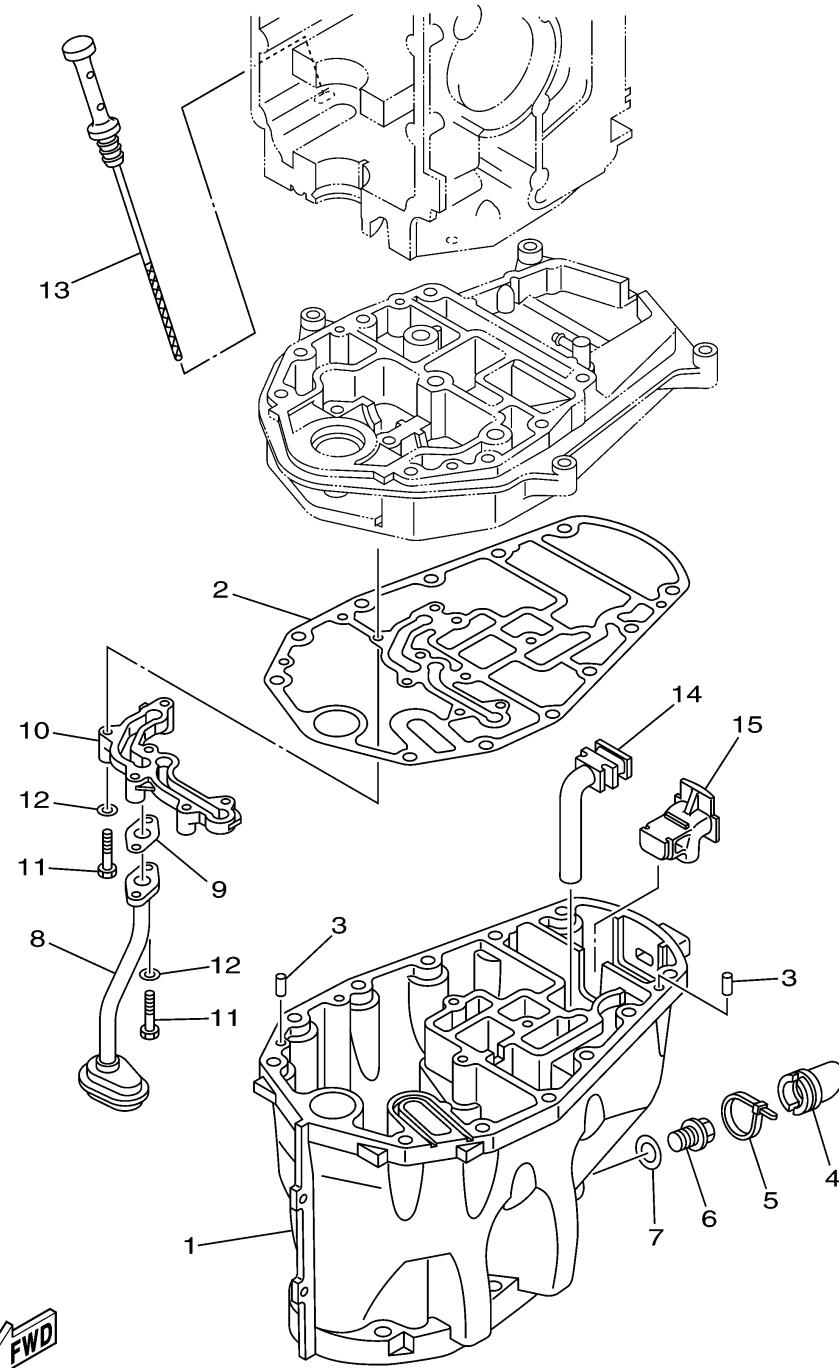

  
 6C11010-D300