

# INTAKE

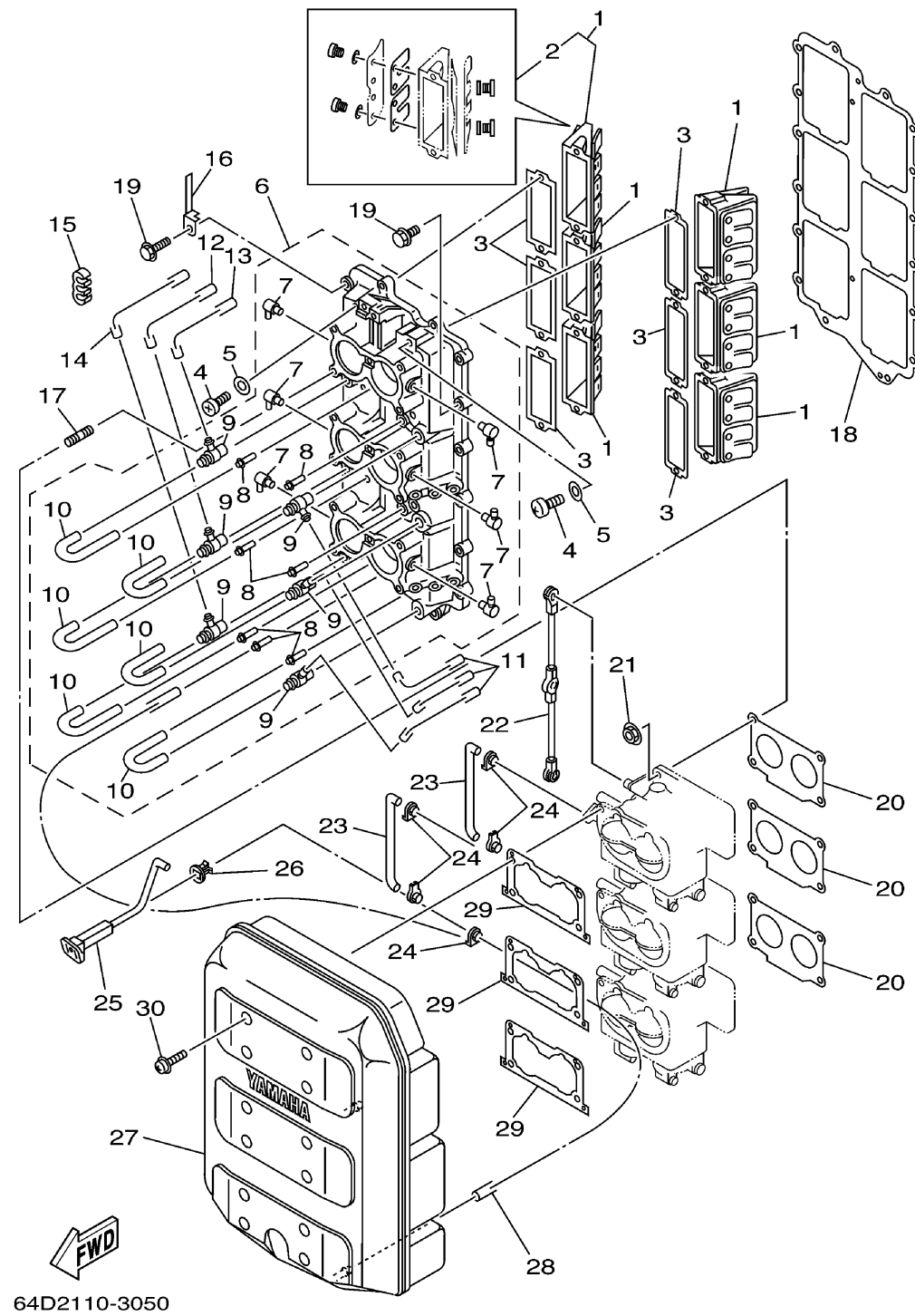

Ref No.	Part Number	Description	Qty	Remarks
1	6E5-13610-00-00	REED VALVE ASSY	6	
2	6E5-W0004-00-00	.REED SET	1	
3	6E5-13621-A1-00	.GASKET, VALVE SEAT	6	
4	97880-05016-00	SCREW, PAN HEAD	12	
5	92990-05600-00	WASHER, PLATE	12	
6	6G5-13641-11-1S	MANIFOLD 1	1	
7	6E5-13552-01-00	.NOZZLE	6	
8	624-14485-00-00	.PIPE, JOINT	7	
9	6E5-11370-01-00	.CHECK VALVE ASSY	6	
10	90445-07M28-00	.HOSE (L70)	6	
11	90445-07M45-00	HOSE (L340)	3	
12	90445-07M46-00	HOSE (L360)	1	
13	90445-07M09-00	HOSE (L380)	1	
14	90445-07M59-00	HOSE (L410)	1	
15	90464-07M05-00	CLAMP	2	
16	90465-10M91-00	CLAMP	2	
17	90116-06M30-00	BOLT, STUD	12	
18	6G5-13645-A2-00	.GASKET, MANIFOLD 1	1	
19	90119-06MA3-00	BOLT, WITH WASHER	16	
20	6E5-14198-A2-00	.GASKET	3	

CONTINUED ON NEXT FRAME >

# INTAKE

Ref No.	Part Number	Description	Qty	Remarks
21	90179-06M28-00	NUT	12	
22	6G5-41217-01-00	ROD, ACCEL. LEVER	1	
23	6E5-41256-01-00	ROD, CHOKE 1	2	
24	661-41262-02-00	JOINT, CHOKE LEVER	5	
25	6R3-41271-00-00	KNOB, CHOKE	1	
26	689-41273-00-00	GROMMET	1	
27	64D-14440-00-00	SILENCER ASSY, INTAKE	1	
28	90445-07MA3-00	HOSE (L200)	1	
29	6K7-14483-00-00	GASKET	3	
30	90159-06M08-00	SCREW, WITH WASHER	12	

