

63V8110-H160

BRACKET 2

Ref No.	Part Number	Description	Qty	Remarks
1	93700-06M03-00	NIPPLE, GREASE	1	
2	63V-42528-00-00	PLATE, FRICTION	1	
3	689-43373-01-00	SEAL, DAMPER	1	
4	90105-06M07-00	.BOLT, FLANGE	1	
5	63V-82127-00-00	WIRE, LEAD 2	1	
6	63V-42511-04-4D	BRACKET, STEERING	1	
7	90209-40008-00	WASHER	1	
8	65F-42537-00-00	BUSHING, PIVOT SHAFT	1	
9	90386-30048-00	BUSH	1	
10	93210-29M94-00	O-RING	1	
11	90386-30M60-00	BUSH	1	
12	90116-08M54-00	BOLT, STUD	2	
13	63V-44514-01-5B	MOUNT DAMPER, UPPER SIDE	1	
14	63V-44526-00-00	PLATE	1	
15	95380-08600-00	NUT	2	
16	90387-16002-00	COLLAR	1	
17	63V-44366-01-00	DAMPER, WATER SEAL	1	
18	63V-45114-A1-00	GASKET, UPPER CASING	1	
19	97095-06018-00	.BOLT	3	
20	92995-06600-00	WASHER	3	

CONTINUED ON NEXT FRAME >

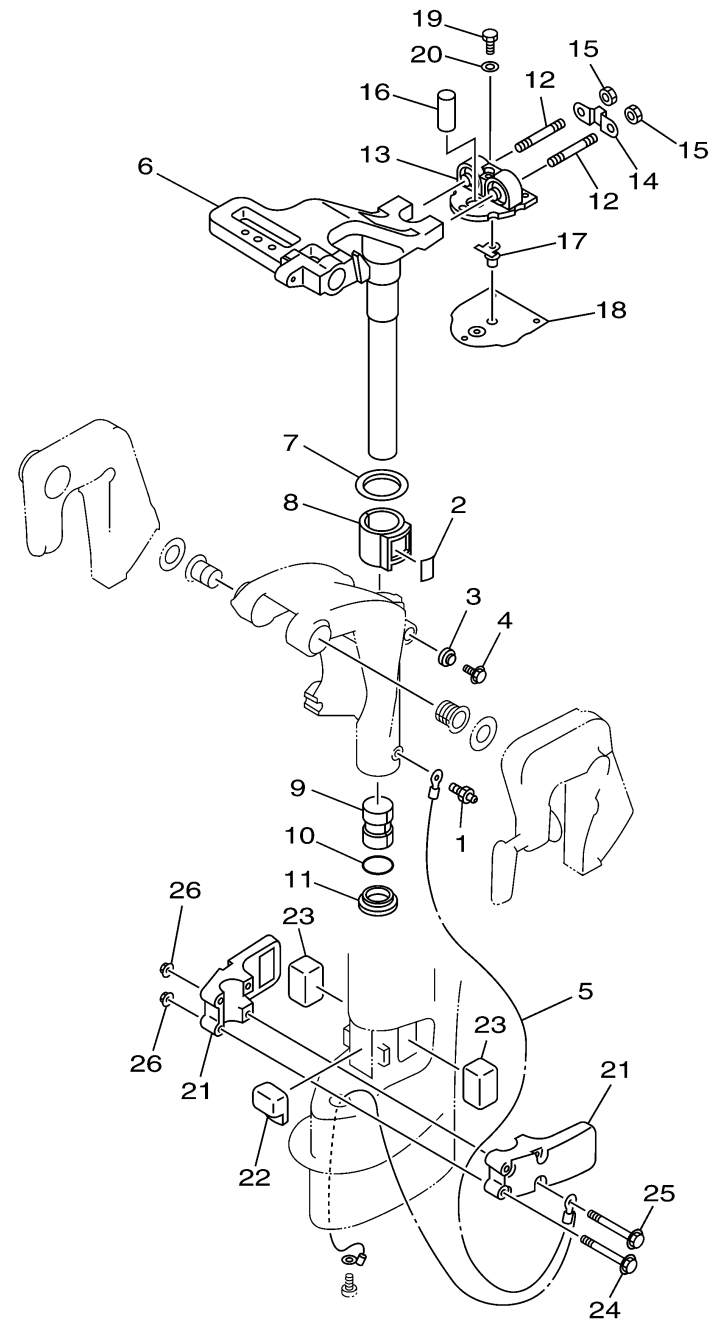

BRACKET 2

Ref No.	Part Number	Description	Qty	Remarks
21	63V-44551-01-4D	HOUSING, LOWER MOUNT RUBBER	2	
22	63V-44557-00-00	MOUNT DAMPER, LOWER FRONT	1	
23	682-44555-00-00	MOUNT DAMPER, LOWER SIDE	2	
24	97575-06555-00	BOLT, WITH WASHER	2	
25	97575-06575-00	BOLT, WITH WASHER	2	
26	90179-06M28-00	NUT	4	



63V8110-H160