

CRANKSHAFT PISTON

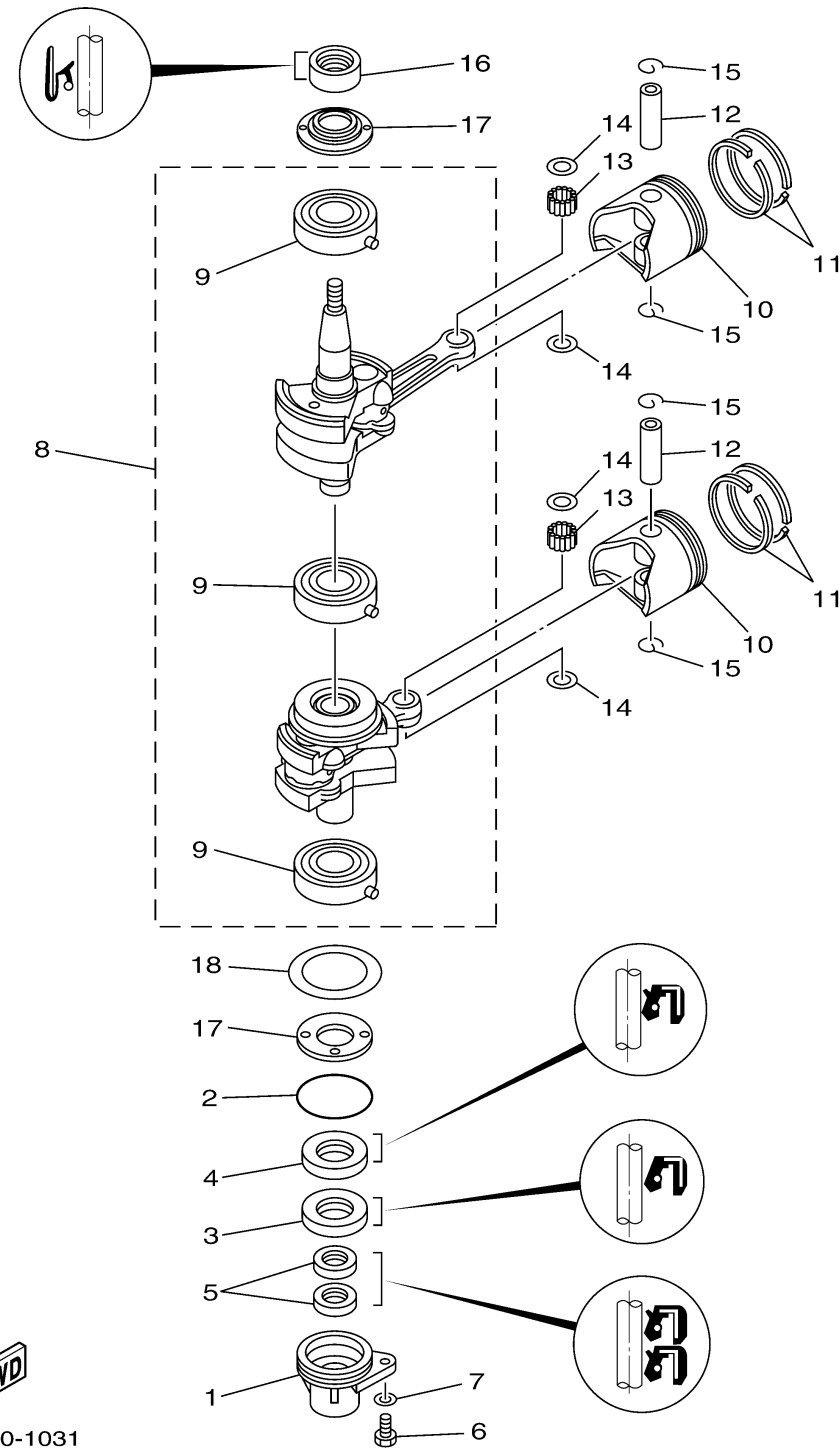

Ref No.	Part Number	Description	Qty	Remarks
1	63V-15396-01-94	HOUSING, OIL SEAL	1	
2	93210-46M16-00	.O-RING	1	
3	93101-25018-00	.OIL SEAL	1	
4	93102-25M48-00	.OIL SEAL	1	
5	93101-13018-00	.OIL SEAL	2	
6	97095-06016-00	BOLT	1	
7	92995-06600-00	WASHER	1	
8	63V-11400-01-00	CRANKSHAFT ASSY	1	
9	93306-205U7-00	. .BEARING	3	
10	6E7-11635-00-00	PISTON (0.25MM O/S)	2	AP
10	6E7-11636-00-00	PISTON (0.50MM O/S)	2	AP
10	6E7-11631-00-97	PISTON (STD)	2	
11	682-11610-01-00	PISTON RING SET (STD)	2	
11	682-11610-21-00	PISTON RING SET (0.50MM O/S)	2	AP
11	682-11610-11-00	PISTON RING SET (0.25MM O/S)	2	AP
12	634-11633-00-00	PIN, PISTON	2	
13	93602-14104-00	PIN, DOWEL	50	
14	90201-14377-00	WASHER, PLATE	4	
15	93450-15023-00	CIRCLIP	4	
16	93110-23M00-00	.OIL SEAL	1	

CONTINUED ON NEXT FRAME >

63V0110-1031

CRANKSHAFT PISTON

Ref No.	Part Number	Description	Qty	Remarks
17	63V-11445-00-00	.SPACER	2	
18	90201-46M29-00	.WASHER, PLATE	1	

