

CRANKSHAFT PISTON

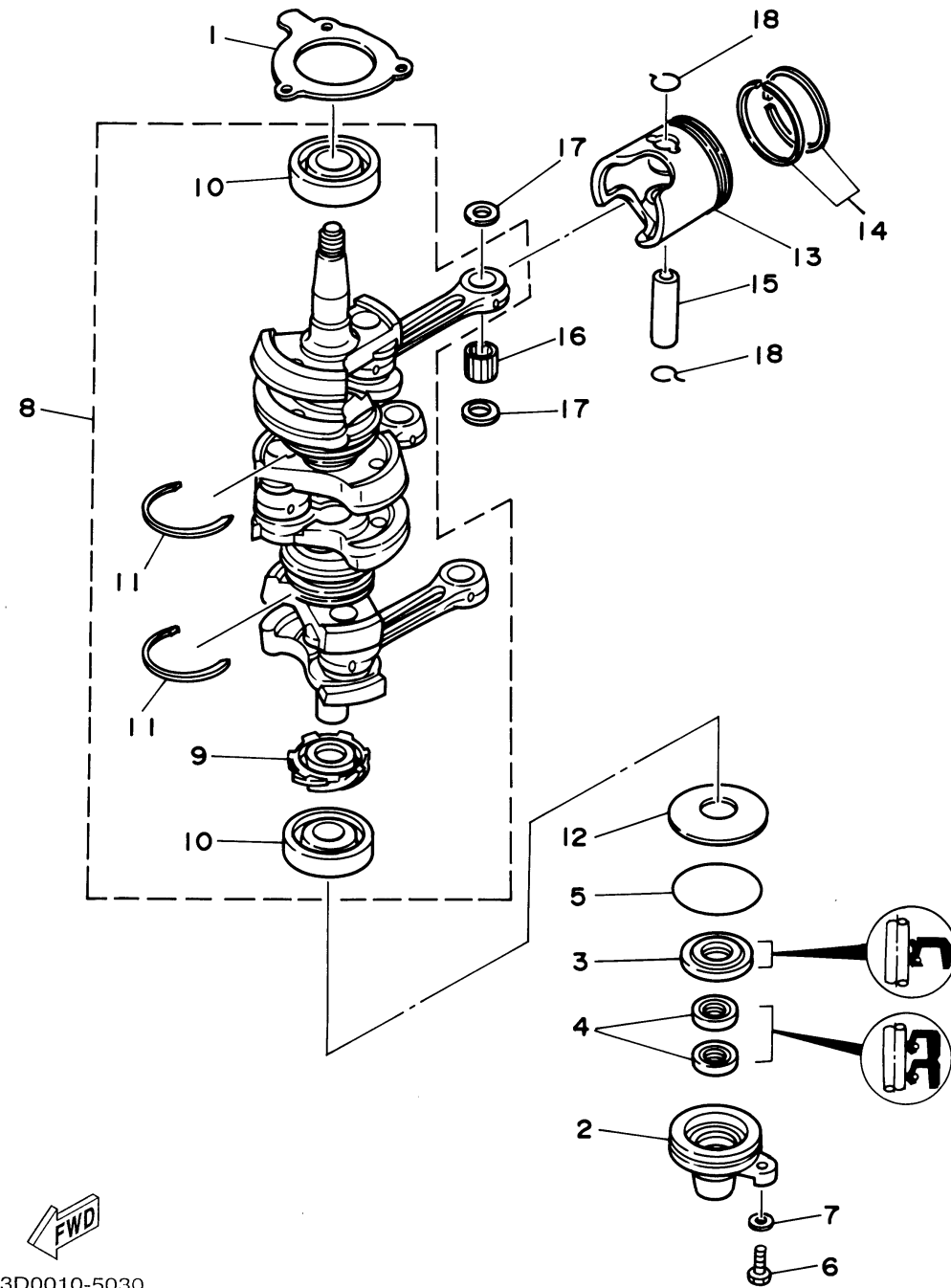

Ref No.	Part Number	Description	Qty	Remarks
1	6H4-15369-A1-00	GASKET, OIL SEAL HOUSING	1	
2	6H4-15396-03-5B	HOUSING, OIL SEAL	1	
3	93102-25M28-00	OIL SEAL	1	
4	93104-16M01-00	.OIL SEAL	2	
5	93210-58M21-00	.O-RING	1	
6	97095-06020-00	BOLT	1	
7	92995-06600-00	WASHER	1	
8	6H4-11400-14-00	CRANKSHAFT ASSY	1	
9	6H4-11536-00-00	.GEAR, DRIVE	1	
10	93306-305U8-00	.BEARING	2	
11	93440-62057-00	.CIRCLIP	2	
12	90201-50306-00	WASHER, PLATE	1	
13	6H4-11635-01-00	PISTON (0.25MM O/S)	3	AP
13	6H4-11631-01-95	PISTON (STD)	3	
13	6H4-11636-01-00	PISTON (0.50MM O/S)	3	AP
14	63D-11605-00-00	PISTON RING SET (0.50MM O/S)	3	AP
14	63D-11604-00-00	PISTON RING SET (0.25MM O/S)	3	AP
14	63D-11603-00-00	PISTON RING SET (STD)	3	
15	648-11633-00-00	PIN, PISTON	3	
16	93602-20M02-00	PIN, DOWEL	93	

CONTINUED ON NEXT FRAME >

63D0010-5030

CRANKSHAFT PISTON

Ref No.	Part Number	Description	Qty	Remarks
17	6H4-11641-00-00	WASHER, PISTON PIN	6	
18	6H4-11634-01-00	CLIP, PISTON PIN	6	

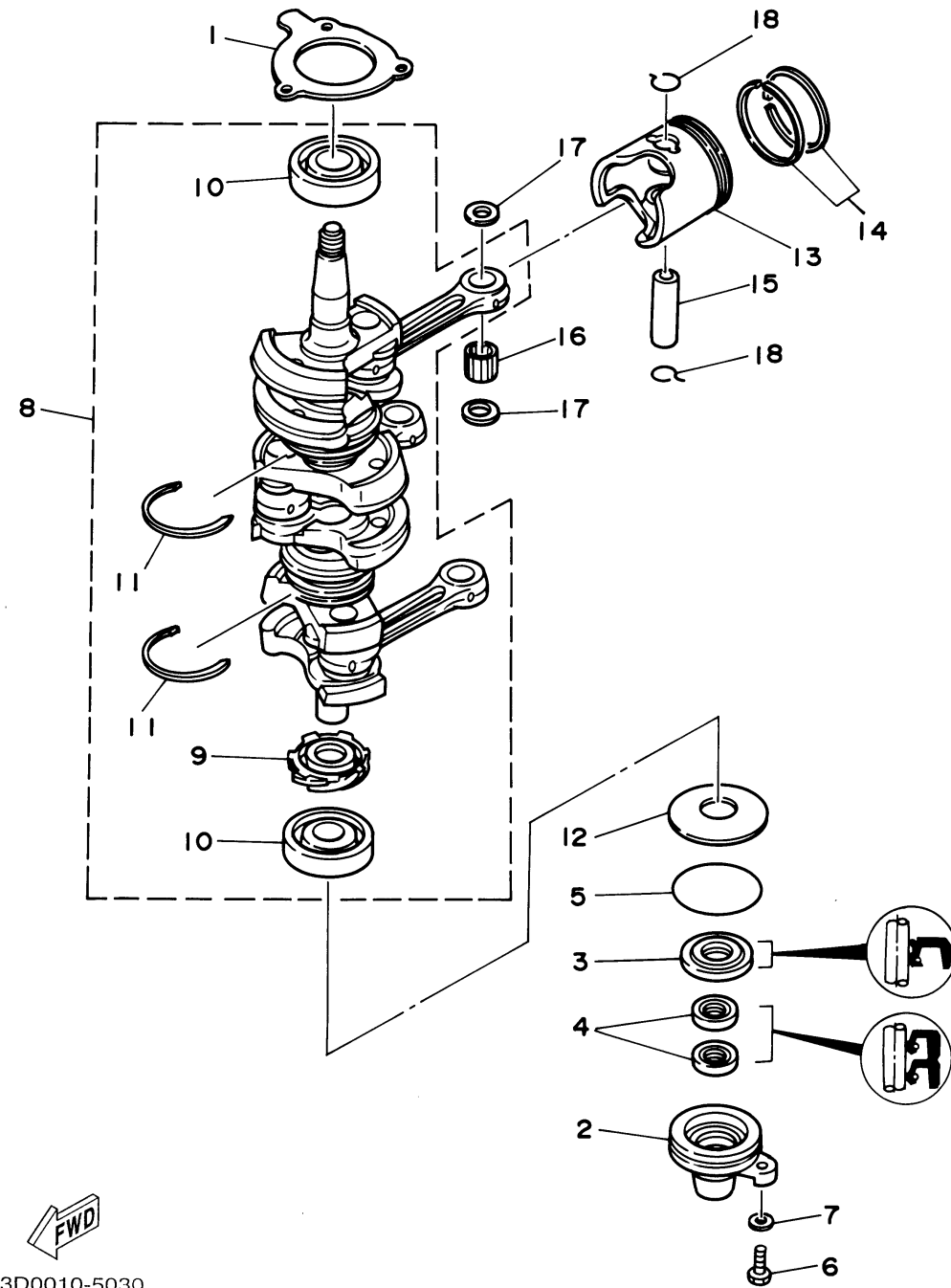

63D0010-5030