

ELECTRICAL

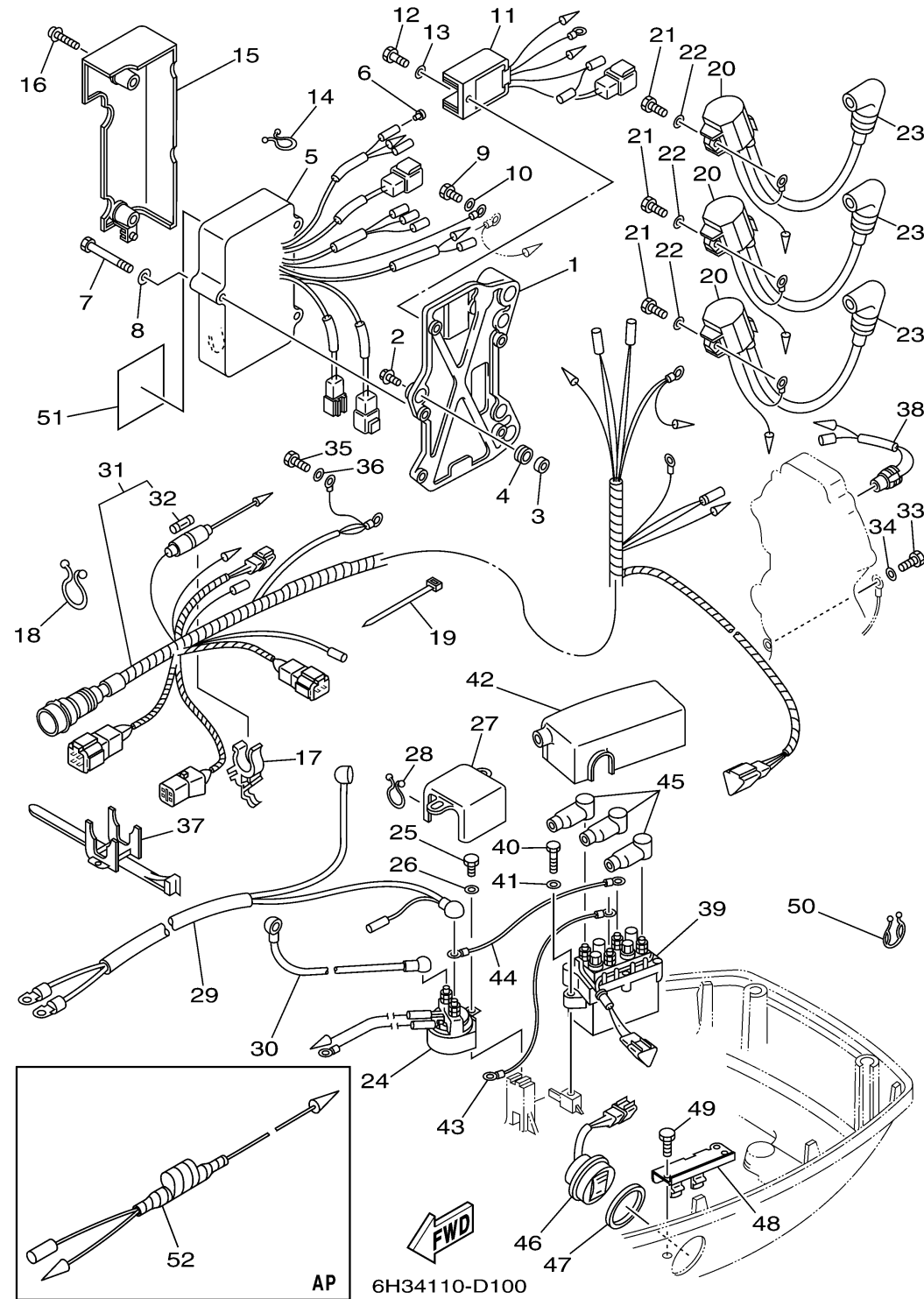

Ref No.	Part Number	Description	Qty	Remarks
1	6H3-85542-11-94	BRACKET	1	
2	90105-06M14-00	BOLT FLANGE	3	
3	90387-06M43-00	COLLAR	3	
4	90480-13M54-00	GROMMET	3	
5	6H2-85540-13-00	C.D.I. PUSH TO OPEN THROTTLE	1	
6	703-82119-00-00	COVER, LEAD WIRE	1	
7	97095-06045-00	.BOLT	3	
8	92995-06600-00	WASHER	3	
9	97013-06012-00	BOLT	1	
10	92903-06600-00	WASHER, PLATE	1	
11	6H2-81960-10-00	RECTIFIER & REGULATOR ASSY	1	
12	97095-06016-00	BOLT	1	
13	92995-06600-00	WASHER	1	
14	90464-05M16-00	CLAMP	1	
15	6H3-81916-10-00	COVER, TERMINAL	1	
16	90159-06M01-00	SCREW, WITH WASHER	2	
17	6G5-82152-00-00	HOLDER, FUSE	1	
18	90464-23M22-00	CLAMP	1	
19	90465-13M11-00	CLAMP	1	
20	697-85570-00-00	IGNITION COIL ASSY	3	

CONTINUED ON NEXT FRAME >

ELECTRICAL

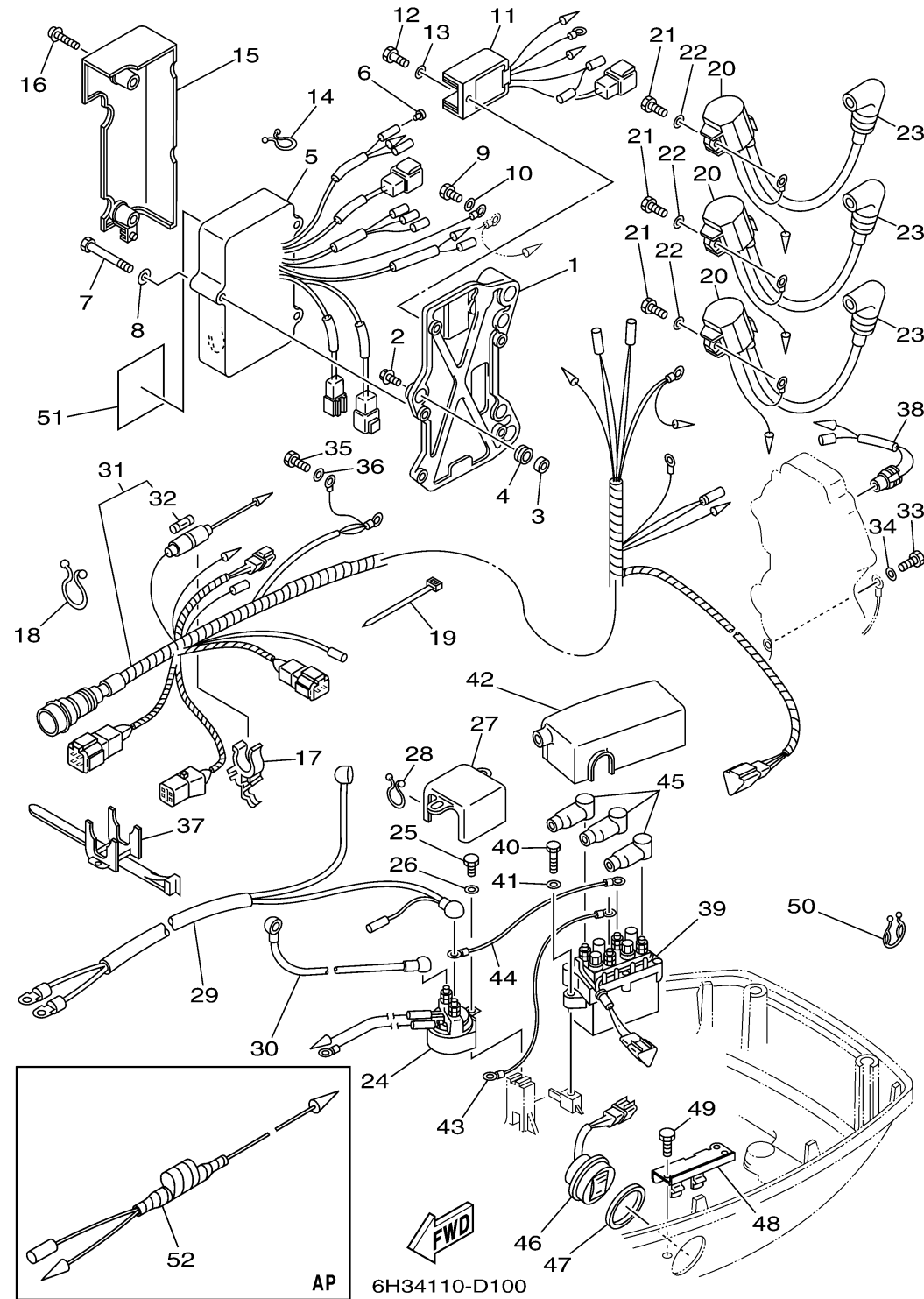

Ref No.	Part Number	Description	Qty	Remarks
21	97013-06020-00	BOLT	3	
22	92903-06600-00	WASHER, PLATE	3	
23	6G1-82370-21-00	PLUG CAP ASSY	3	
24	688-81950-10-00	RELAY ASSY	1	
25	97013-06016-00	BOLT	1	
26	92903-06600-00	WASHER, PLATE	1	
27	6H3-82164-00-00	CASE 2	1	
28	90464-15M11-00	CLAMP	1	
29	6H3-82105-U0-00	BATTERY CABLE	1	
30	6H3-82117-00-00	WIRE, LEAD	1	
31	6H2-82590-80-00	WIRE HARNESS ASSY (10P)	1	
32	663-82151-00-00	. . FUSE (12V-20A)	1	
33	97013-06012-00	BOLT	1	
34	92903-06600-00	WASHER, PLATE	1	
35	97013-06012-00	BOLT	2	
36	92903-06600-00	WASHER, PLATE	2	
37	688-82594-00-00	CLAMP	1	
38	688-82560-10-00	THERMO SWITCH ASSY	1	
39	61A-81950-00-00	RELAY ASSY	1	
40	97095-06025-00	.BOLT	2	

CONTINUED ON NEXT FRAME >

ELECTRICAL

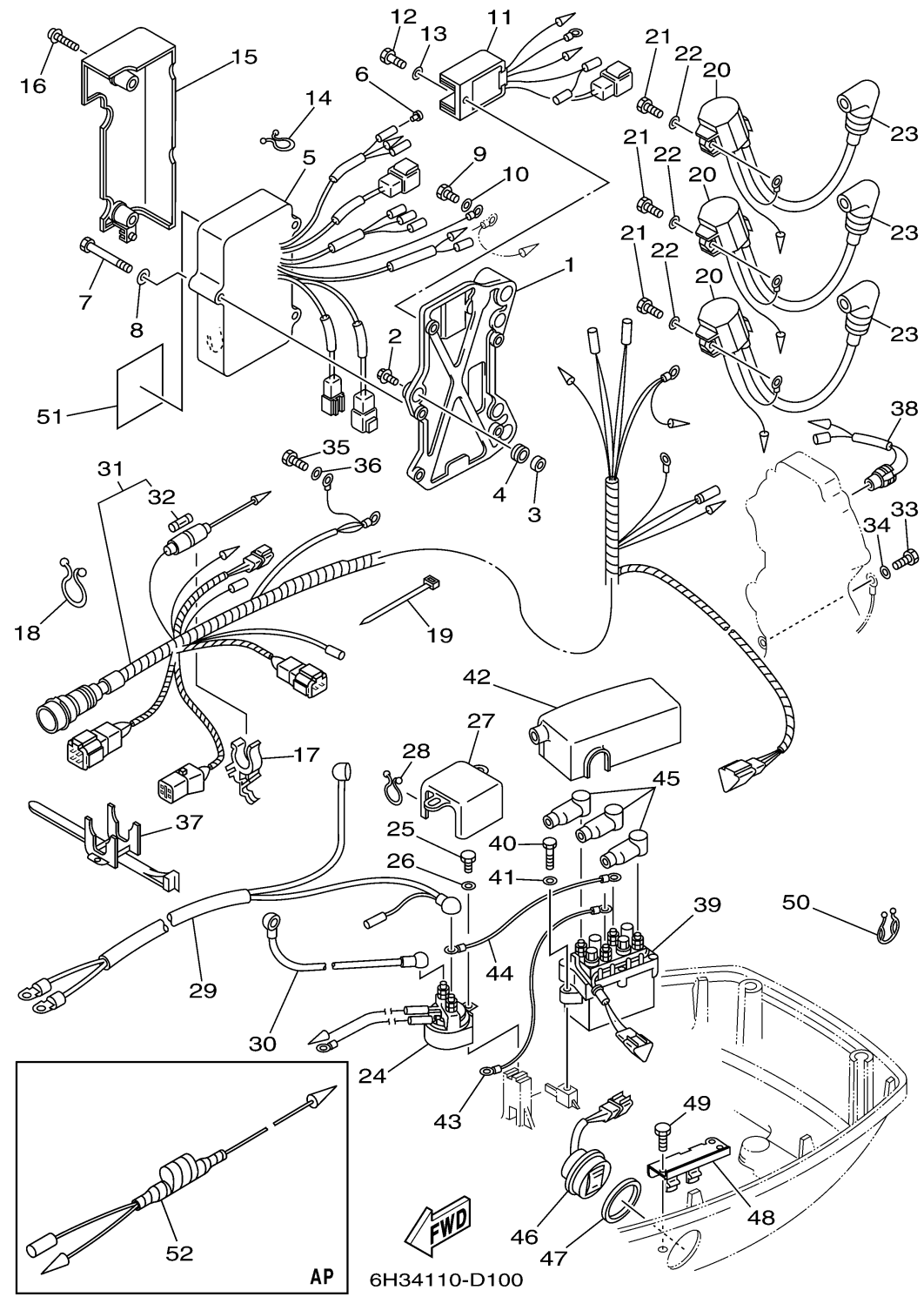

Ref No.	Part Number	Description	Qty	Remarks
41	92995-06600-00	WASHER	2	
42	6H3-82154-11-00	CASE	1	
43	6H2-81949-11-00	WIRE, LEAD	1	
44	6H2-81949-01-00	WIRE, LEAD	1	
45	682-82119-01-00	COVER, LEAD WIRE	3	
46	6H1-82563-10-00	TRIM & TILT SWITCH ASSY	1	
47	6E5-82587-00-00	GASKET	1	
48	6E5-83614-01-00	BRACKET	1	
49	97095-06016-00	BOLT	1	
50	90464-18M14-00	CLAMP	1	
51	6R5-85711-60-00	MARK, CAUTION	1	
52	6H4-81315-11-00	LEAD WIRE ASSY	1	AP