

CONTROL

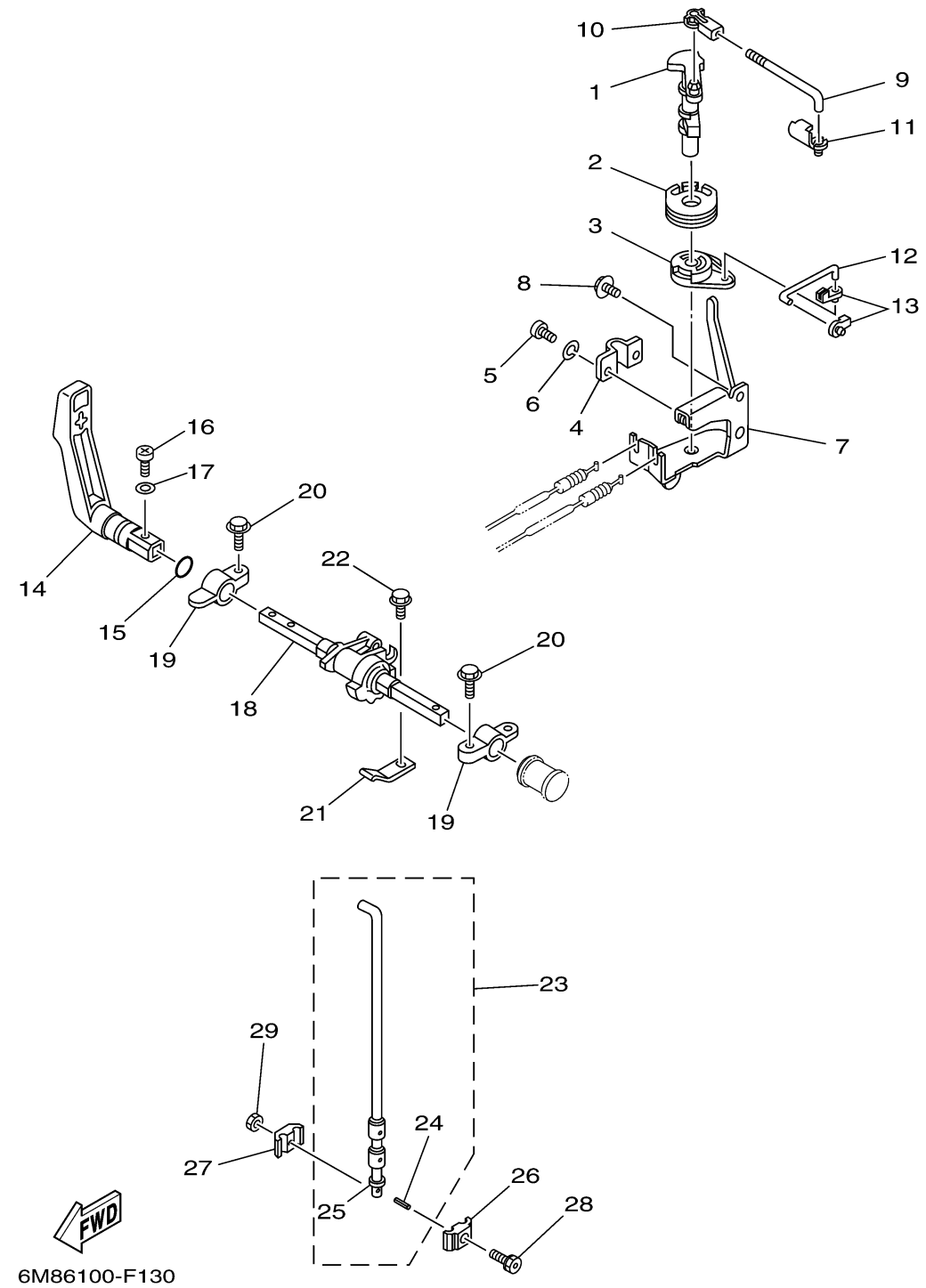

Ref No.	Part Number	Description	Qty	Remarks
1	6G1-41631-00-00	LEVER, MAGNETO CONTROL	1	
2	6G1-41638-00-00	PULLEY	1	
3	6G1-41283-01-00	LEVER, FREE ACCEL.	1	
4	6G1-41661-00-00	BRACKET 1	1	
5	97880-05010-00	SCREW, PAN HEAD	2	
6	92990-05100-00	WASHER, SPRING	2	
7	6G1-14497-81-00	STAY, THROTTLE WIRE	1	
8	95895-06010-00	BOLT, FLANGE	2	
9	6G1-41238-00-00	JOINT, LINK	1	
10	662-41237-01-00	JOINT, LINK	1	
11	6E9-41237-00-00	JOINT, LINK	1	
12	6G1-41211-00-00	LINK, ACCEL.	1	
13	661-41262-02-00	JOINT, CHOKE LEVER	2	
14	6N0-G4111-00-00	HANDLE, GEAR SHIFT	1	
15	93210-12327-00	.O-RING	1	
16	97880-05016-00	SCREW, PAN HEAD	1	
17	92990-05600-00	WASHER, PLATE	1	
18	6G1-44121-02-94	LEVER, SHIFT ROD	1	
19	6G1-41662-01-94	BRACKET 2	2	
20	90105-06M14-00	BOLT FLANGE	2	

CONTINUED ON NEXT FRAME >

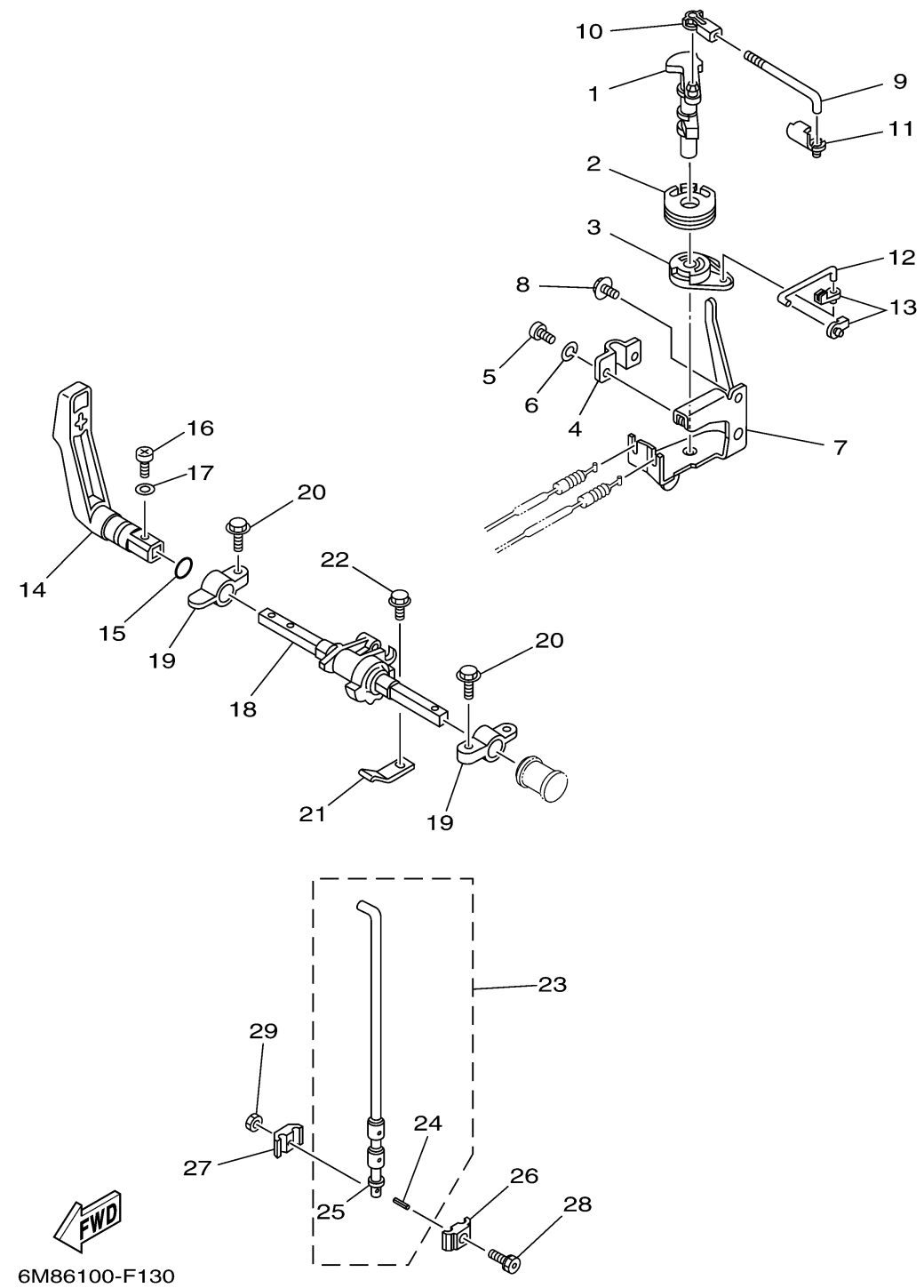

CONTROL

Ref No.	Part Number	Description	Qty	Remarks
21	6G1-44116-01-00	SPRING	1	
22	95895-06012-00	BOLT, FLANGE	1	
23	6N0-G4110-00-00	SHIFT ROD ASSY	1	
24	91690-20010-00	. PIN, SPRING	3	
25	92990-05600-00	. WASHER, PLATE	1	
26	6N0-G4145-10-00	CONNECTOR, SHIFT ROD 1	1	UR
26	6N0-G4145-00-00	CONNECTOR, SHIFT ROD	1	UR
27	6N0-G4146-10-00	CONNECTOR, SHIFT ROD 2	1	UR
27	6N0-G4146-00-00	CONNECTOR, SHIFT ROD	1	UR
28	90109-06M17-00	BOLT	1	
29	95380-06600-00	NUT, HEXAGON	1	