

68V2010-3262

OIL PAN

Ref No.	Part Number	Description	Qty	Remarks
1	68V-15311-00-CA	OIL PAN	1	
2	63P-15316-00-00	DAMPER 1	1	
3	90340-14M06-00	PLUG, STRAIGHT SCREW	1	
4	90430-14M09-00	.GASKET	1	
5	97075-06025-00	BOLT	12	
6	92995-06600-00	WASHER	12	
7	93606-12019-00	PIN, DOWEL	2	
8	68V-15312-00-00	.GASKET, OIL PAN	1	
9	67F-13411-00-00	STRAINER, OIL	1	
10	97027-06025-00	BOLT, HEXAGON	3	
11	92907-06600-00	WASHER, PLATE	3	
12	90387-06M64-00	COLLAR	3	
13	67F-13415-00-00	.SEAL, OIL STRAINER	1	
14	67F-13300-10-00	OIL PUMP ASSY	1	
15	67F-13314-02-00	.SHAFT, PUMP	1	
16	67F-13473-01-00	.O-RING	1	
17	67F-13329-00-00	.GASKET, PUMP COVER	1	
18	67F-13495-00-00	.SCREW	10	
19	67F-13119-01-00	.OIL SEAL	1	
20	67F-13769-00-00	.O-RING	1	

CONTINUED ON NEXT FRAME >

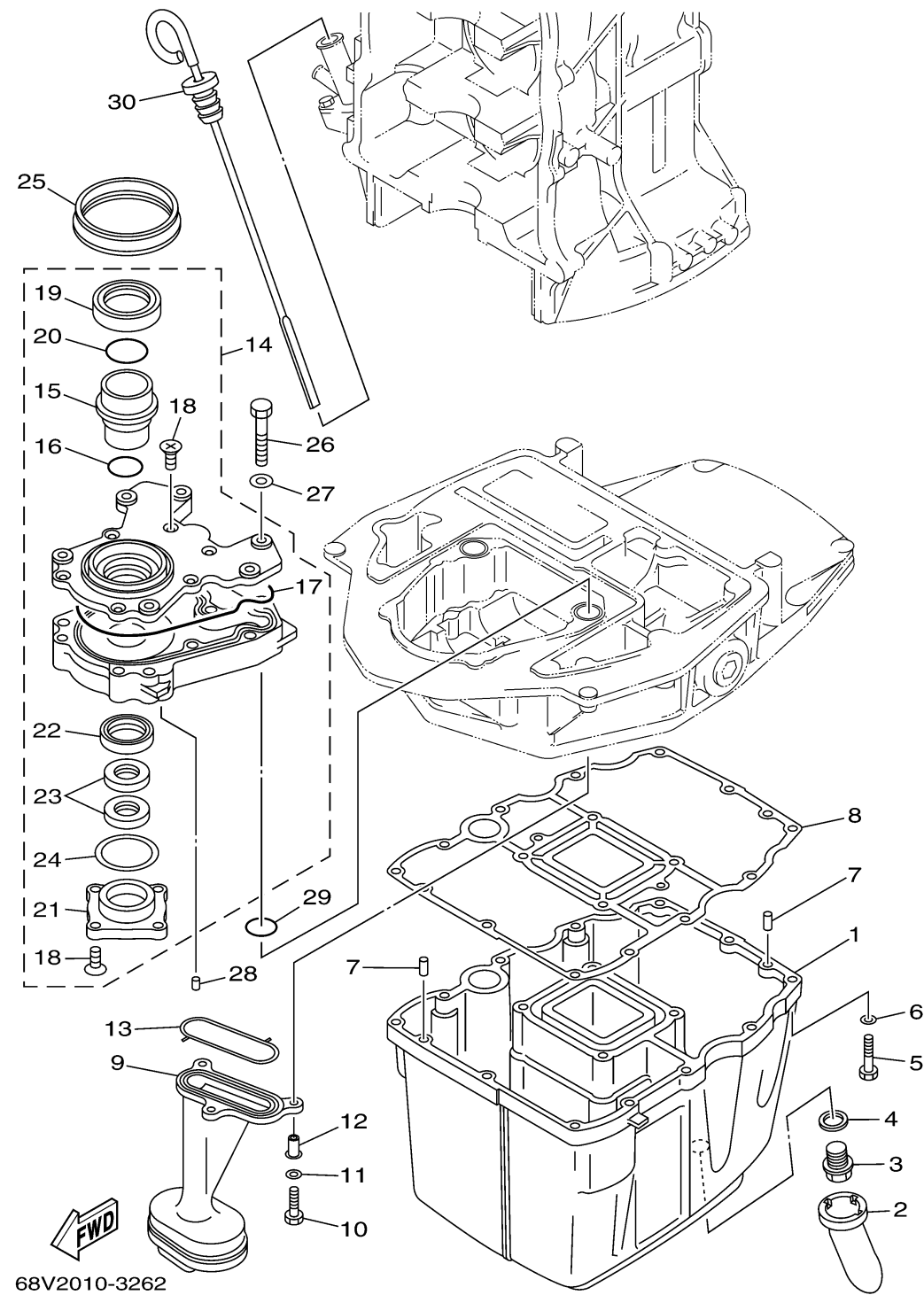

68V2010-3262

OIL PAN

Ref No.	Part Number	Description	Qty	Remarks
21	67F-13914-00-00	.HOUSING, PUMP	1	
22	67F-13631-03-00	.OIL SEAL	1	
23	67F-13149-00-00	.OIL SEAL	2	
24	67F-13339-00-00	.GASKET, PUMP COVER	1	
25	67F-13338-00-00	SEAL	1	
26	97095-06045-00	.BOLT	6	
27	92995-06600-00	WASHER	6	
28	93604-12M07-00	PIN, DOWEL	2	
29	93210-19MJ1-00	.O-RING	2	
30	6D8-15362-00-00	PLUG, OIL LEVEL	1	