

CONTROL

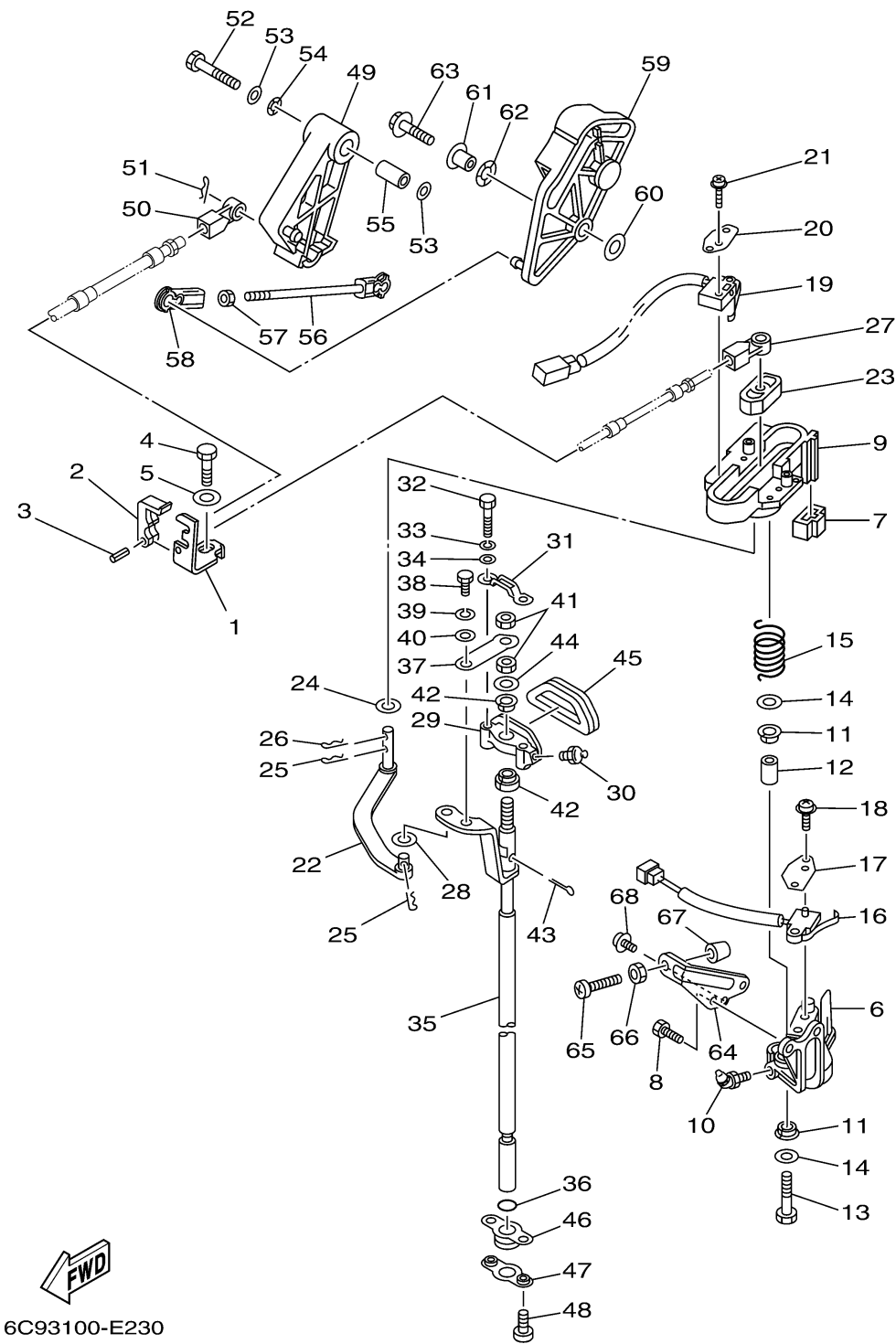

Ref No.	Part Number	Description	Qty	Remarks
1	60V-48531-20-00	BRACKET, REMOTE CONTROL 1	1	
2	663-48538-00-00	CLAMP, CABLE 1	1	
3	91690-30010-00	PIN, SPRING	1	
4	97095-08016-00	BOLT	1	
5	92995-08600-00	WASHER	1	
6	6D0-44117-00-94	BRACKET	1	
7	60V-44194-00-00	CAP	1	
8	97095-06020-00	BOLT	2	
9	60V-44176-01-94	BRACKET	1	
10	93700-06M01-00	NIPPLE, GREASE	1	
11	90386-12069-00	BUSH	2	
12	90387-08M09-00	COLLAR	1	
13	97095-08035-00	BOLT	1	
14	92995-08200-00	WASHER	2	
15	90508-20M31-00	SPRING, TORSION	1	
16	61A-8259F-00-00	SWITCH ASSY	1	
17	61A-82588-01-00	PLATE	1	
18	97985-04116-00	SCREW, WITH WASHER	2	
19	60V-8259F-00-00	SWITCH ASSY	1	
20	61A-82588-01-00	PLATE	1	

CONTINUED ON NEXT FRAME >

6C93100-E230

CONTROL

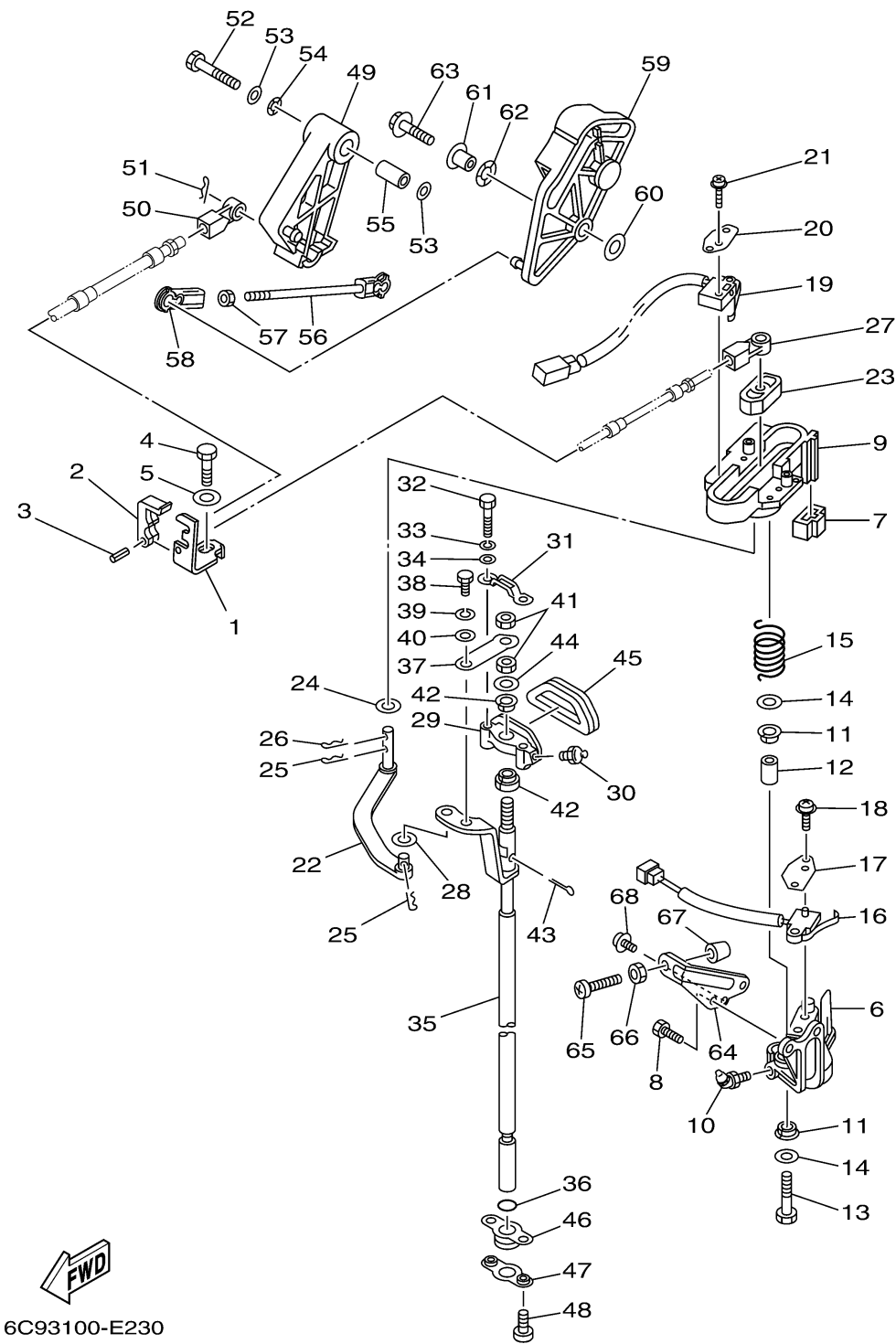

Ref No.	Part Number	Description	Qty	Remarks
21	97985-04116-00	SCREW, WITH WASHER	2	
22	61A-44121-00-00	LEVER, SHIFT ROD	1	
23	68J-44122-01-00	BUSHING, SHIFT ROD LEVER	1	
24	90202-08M20-00	WASHER, PLATE	1	
25	90468-18008-00	CLIP	2	
26	90468-07M06-00	CLIP	1	
27	6E5-48344-00-00	CABLE END, REMOTE CONTROL	1	
28	90202-06007-00	WASHER, PLATE	1	
29	61A-44118-00-94	BRACKET	1	
30	93700-06M03-00	NIPPLE, GREASE	1	
31	61A-44116-00-00	SPRING	1	
32	97095-06030-00	BOLT	2	
33	92995-06100-00	WASHER, SPRING	2	
34	92995-06600-00	WASHER	2	
35	66K-44120-01-00	HANDLE GEAR SHIFT ASSY	1	
36	93210-09165-00	O-RING	1	
37	61A-44112-00-00	STAY, HANDLE GEAR SHIFT	1	
38	97013-06012-00	BOLT	1	
39	92903-06100-00	WASHER, SPRING	1	
40	92903-06600-00	WASHER, PLATE	1	

CONTINUED ON NEXT FRAME >

6C93100-E230

CONTROL

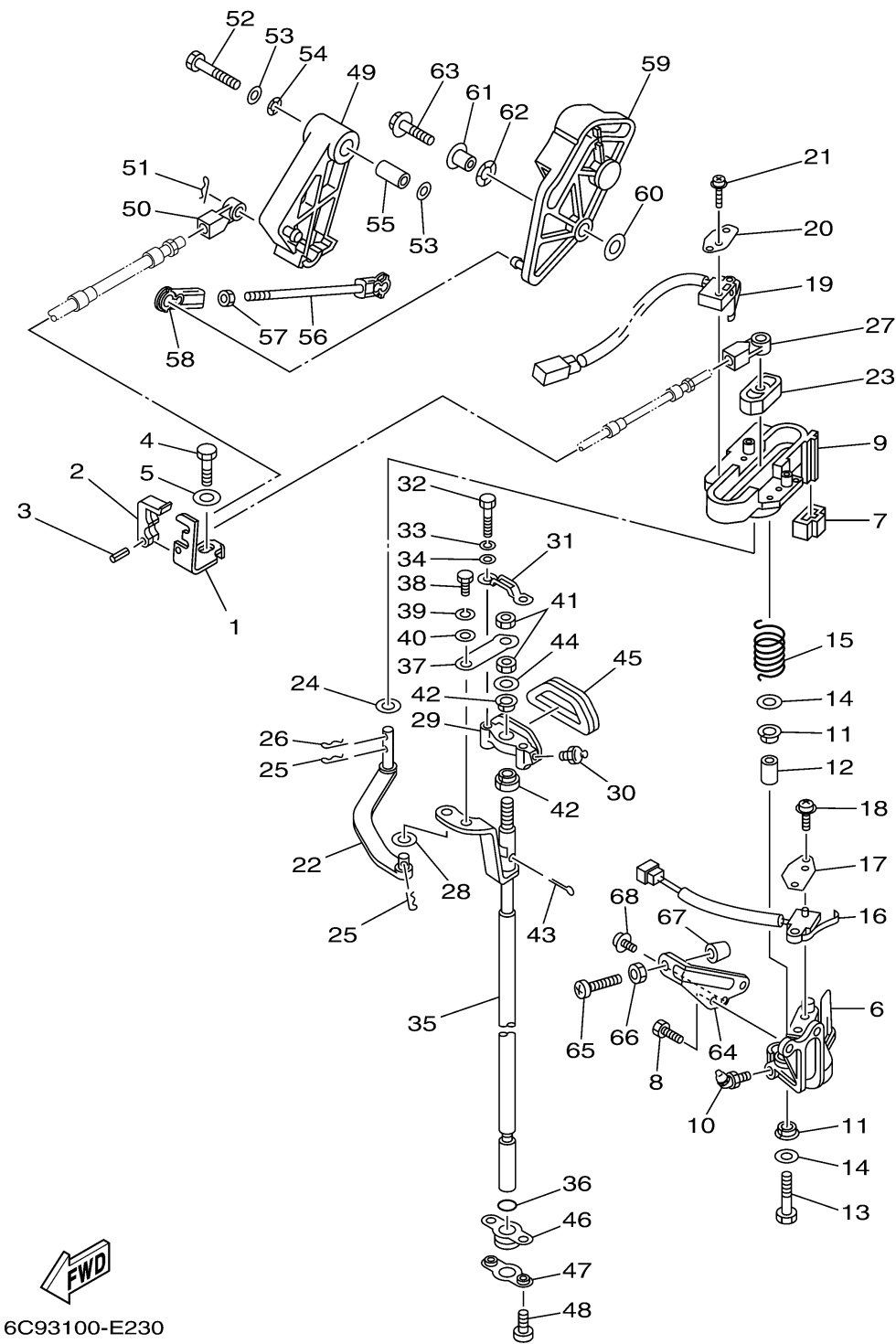

6C93100-E230

Ref No.	Part Number	Description	Qty	Remarks
41	95313-08600-00	NUT	2	
42	90386-90M90-00	BUSH	2	
43	91490-20012-00	PIN. COTTER	1	
44	90201-09M02-00	WASHER, PLATE	1	
45	61A-15315-00-00	SEAL, CRANKCASE	1	
46	61A-42724-00-00	GROMMET	1	
47	61A-44138-00-00	WASHER	1	
48	97885-06008-00	SCREW, PAN HEAD	2	
49	65L-41632-01-00	LEVER, MAGNETO CONTROL	1	
50	6E5-48344-00-00	CABLE END, REMOTE CONTROL	1	
51	90468-18008-00	CLIP	1	
52	97013-08045-00	BOLT	1	
53	92990-08200-00	WASHER, PLAIN	2	
54	90206-12M00-00	WASHER, WAVE	1	
55	90387-08M16-00	COLLAR	1	
56	61A-41237-00-00	JOINT, LINK	1	
57	95380-05600-00	NUT	1	
58	6H4-41237-00-00	JOINT, LINK	1	
59	6D0-41230-00-00	CAM ACCELERATOR COMP	1	
60	90201-06M31-00	WASHER, PLATE	1	

CONTINUED ON NEXT FRAME >

CONTROL

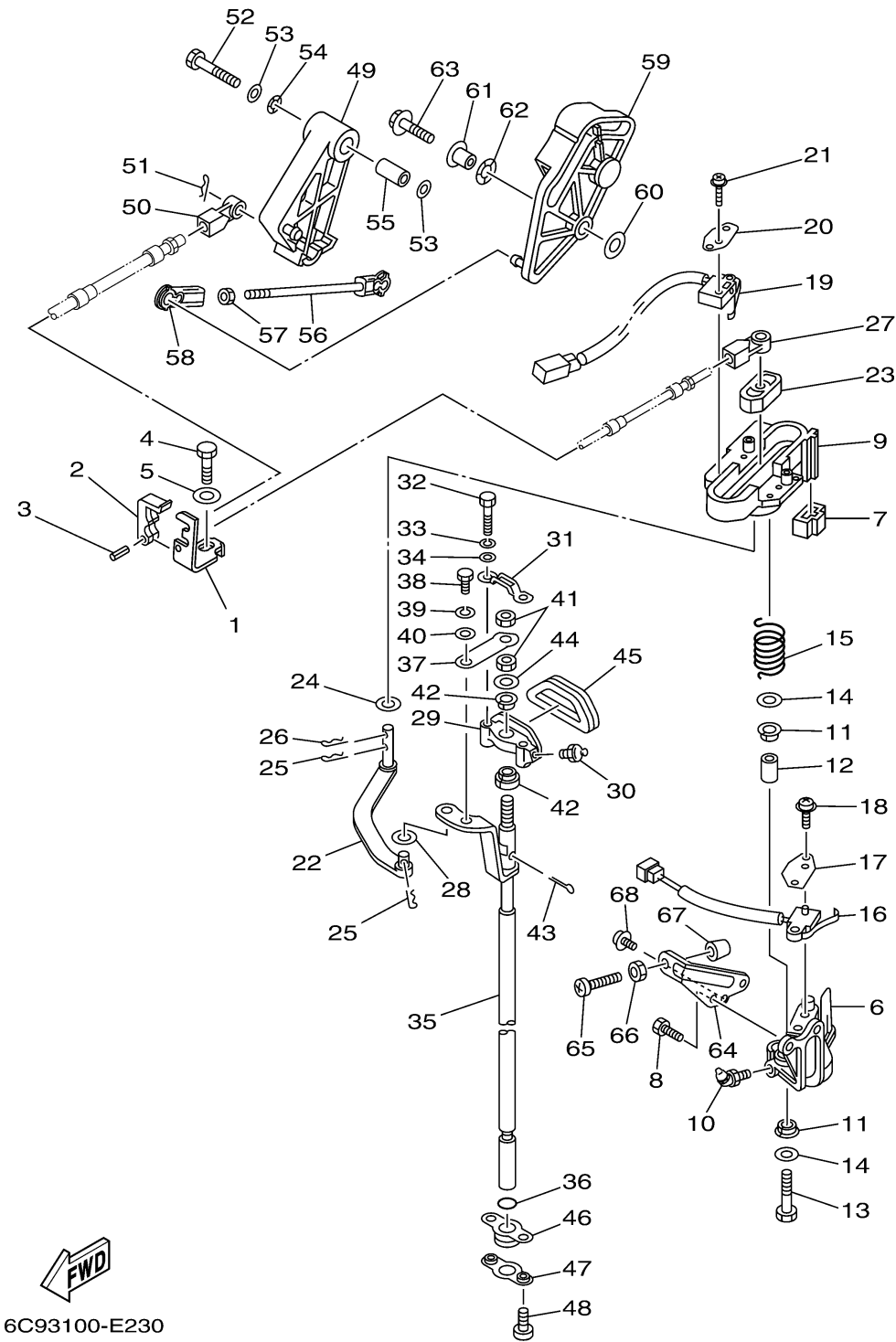

6C93100-E230

Ref No.	Part Number	Description	Qty	Remarks
61	90387-06M29-00	COLLAR	1	
62	90206-10M04-00	WASHER, WAVE	1	
63	90119-06MA4-00	BOLT, WITH WASHER	1	
64	69L-42744-00-00	STAY	1	
65	90157-06006-00	SCREW, PAN HEAD	1	
66	95380-06600-00	NUT, HEXAGON	1	
67	688-44194-00-00	CAP	1	
68	90159-05M25-00	.SCREW, WITH WASHER	1	