

CYLINDER CRANKCASE 1

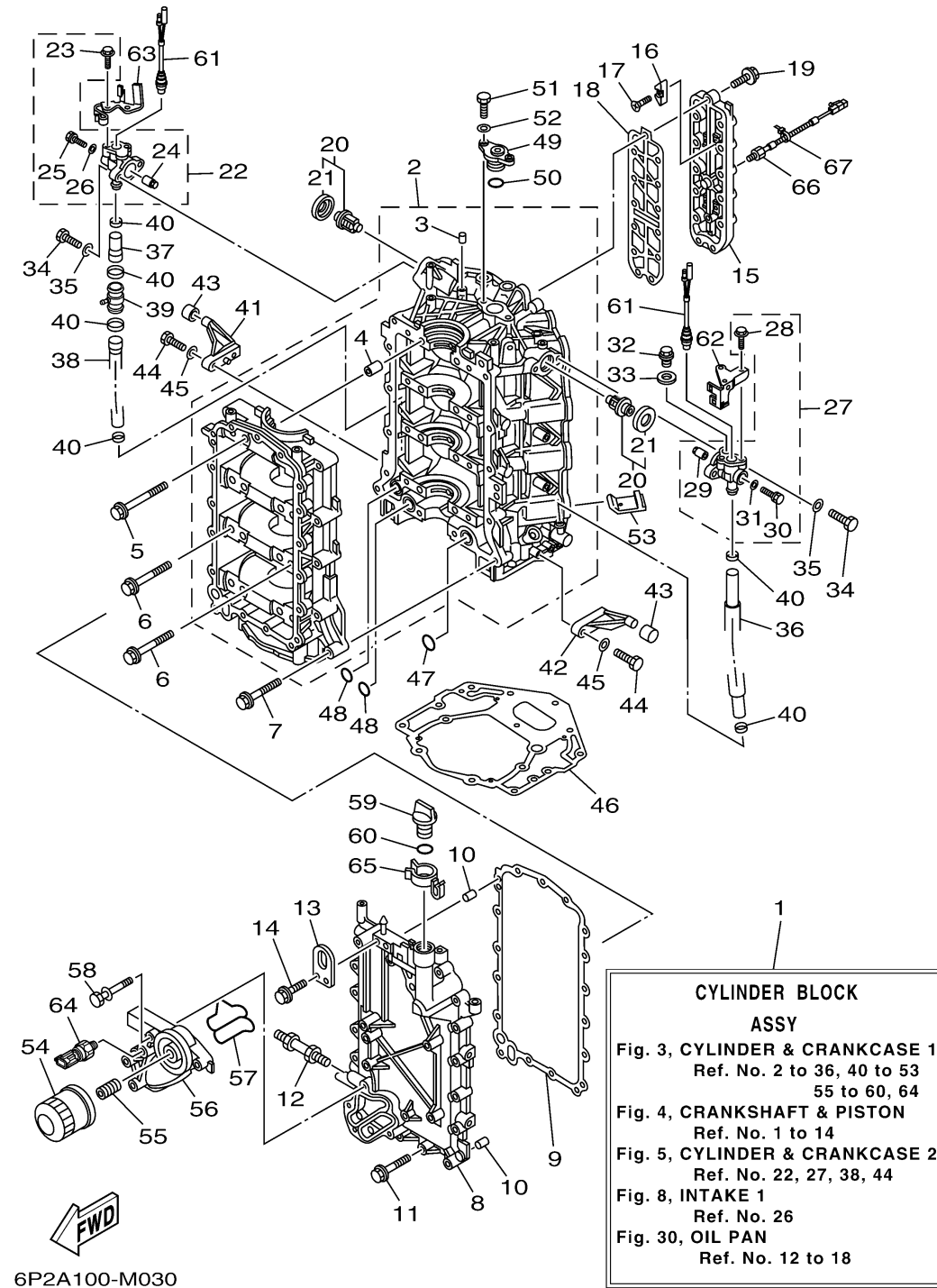

Ref No.	Part Number	Description	Qty	Remarks
1	6P2-W009B-07-9S	CYLINDER BLOCK ASSY	1	UR 6AL: -1004846
1	6P2-W009B-10-9S	CYLINDER BLOCK ASSY	1	UR 6AL: 1004847-
2	6P2-15100-10-00	CRANKCASE ASSY	1	
3	93606-12019-00	. PIN, DOWEL	1	
4	91814-18002-00	. .PIN, DOWEL	8	
5	6P2-15187-00-00	BOLT	8	
6	6P2-15481-00-00	BOLT 1	8	
7	90119-08M66-00	BOLT, WITH WASHER	13	
8	6P2-15411-01-9S	COVER, CRANKCASE 1	1	
9	69J-15451-00-00	.GASKET, CRANKCASE COVER 1	1	
10	93606-12019-00	PIN, DOWEL	2	
11	90119-08009-00	BOLT, WITH WASHER	17	
12	90116-10027-00	BOLT, STUD	1	
13	69J-11119-00-00	HANGER, ENGINE	1	
14	90105-06M09-00	BOLT, FLANGE	2	
15	6P2-1131C-00-9S	COVER, JOINT	1	
16	6E5-11325-00-00	ANODE	4	
17	98780-04015-00	SCREW, FLAT HEAD	4	
18	6P2-1131B-00-00	.GASKET, COVER	1	
19	90119-06MA4-00	BOLT, WITH WASHER	13	

CONTINUED ON NEXT FRAME >

CYLINDER CRANKCASE 1

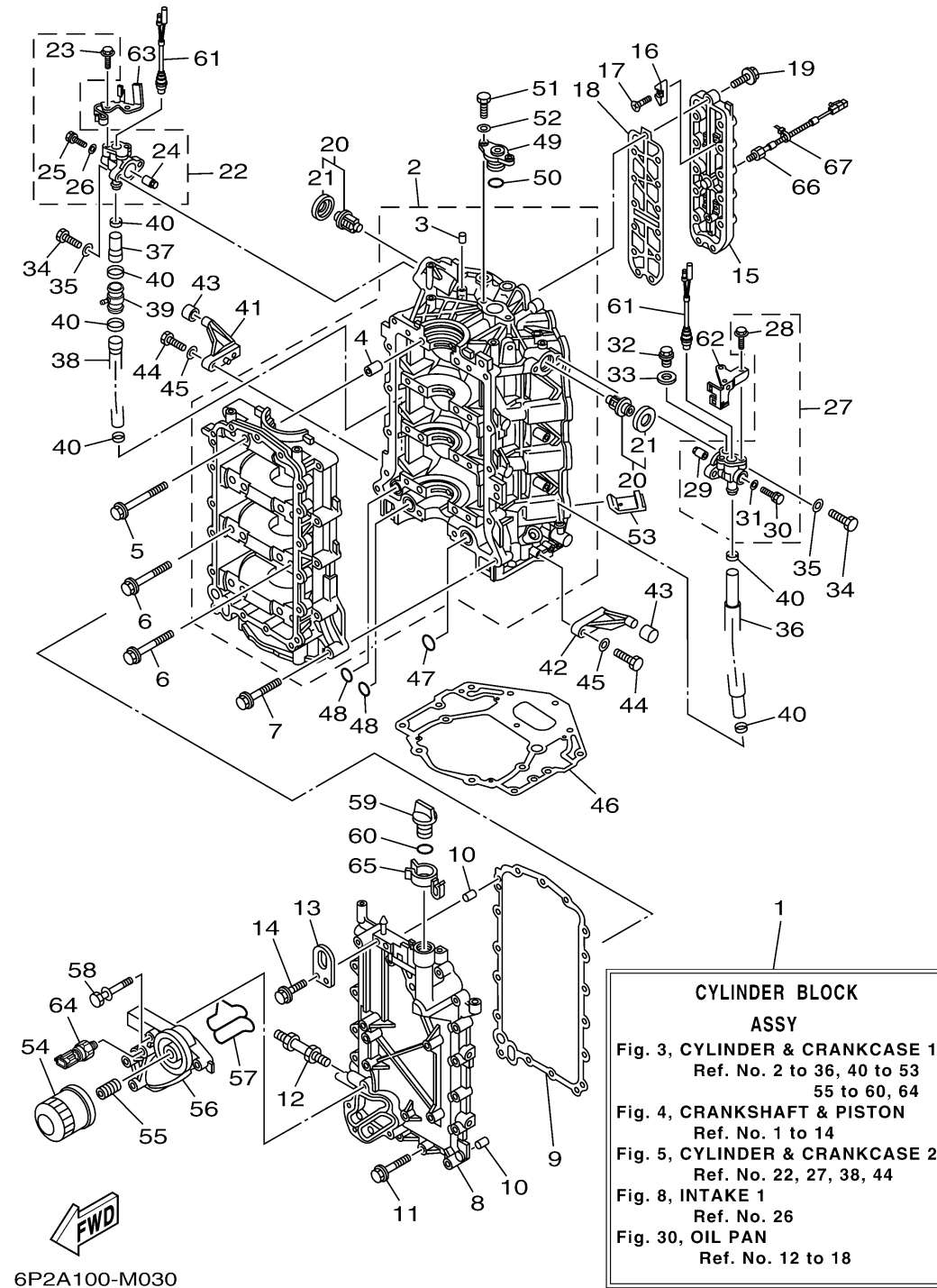

Ref No.	Part Number	Description	Qty	Remarks
20	67F-12411-01-00	THERMOSTAT	2	
21	67F-12412-00-00	. .SEAL, THERMOSTAT	1	
22	6P2-1240H-00-9S	ANODE ASSY	1	
23	90109-06M80-00	. BOLT	2	
24	6P3-11325-00-00	. .ANODE	1	
25	90105-05012-00	. BOLT, FLANGE	1	
26	90430-05002-00	. .GASKET	1	
27	6P3-1240H-00-9S	ANODE ASSY	1	
28	90109-06M80-00	. BOLT	2	
29	6P3-11325-00-00	. .ANODE	1	
30	90105-05012-00	. BOLT, FLANGE	1	
31	90430-05002-00	. .GASKET	1	
32	90340-14M06-00	PLUG, STRAIGHT SCREW	1	
33	90430-14115-00	.GASKET	1	
34	97095-06025-00	.BOLT	4	
35	92995-06600-00	WASHER	4	
36	6P2-1243A-00-00	HOSE 1	1	
37	6P2-1243E-00-00	HOSE 2	1	
38	6P2-1243F-00-00	HOSE,3	1	
39	6CE-24378-00-00	PIPE, JOINT 3	1	

CONTINUED ON NEXT FRAME >

CYLINDER CRANKCASE 1

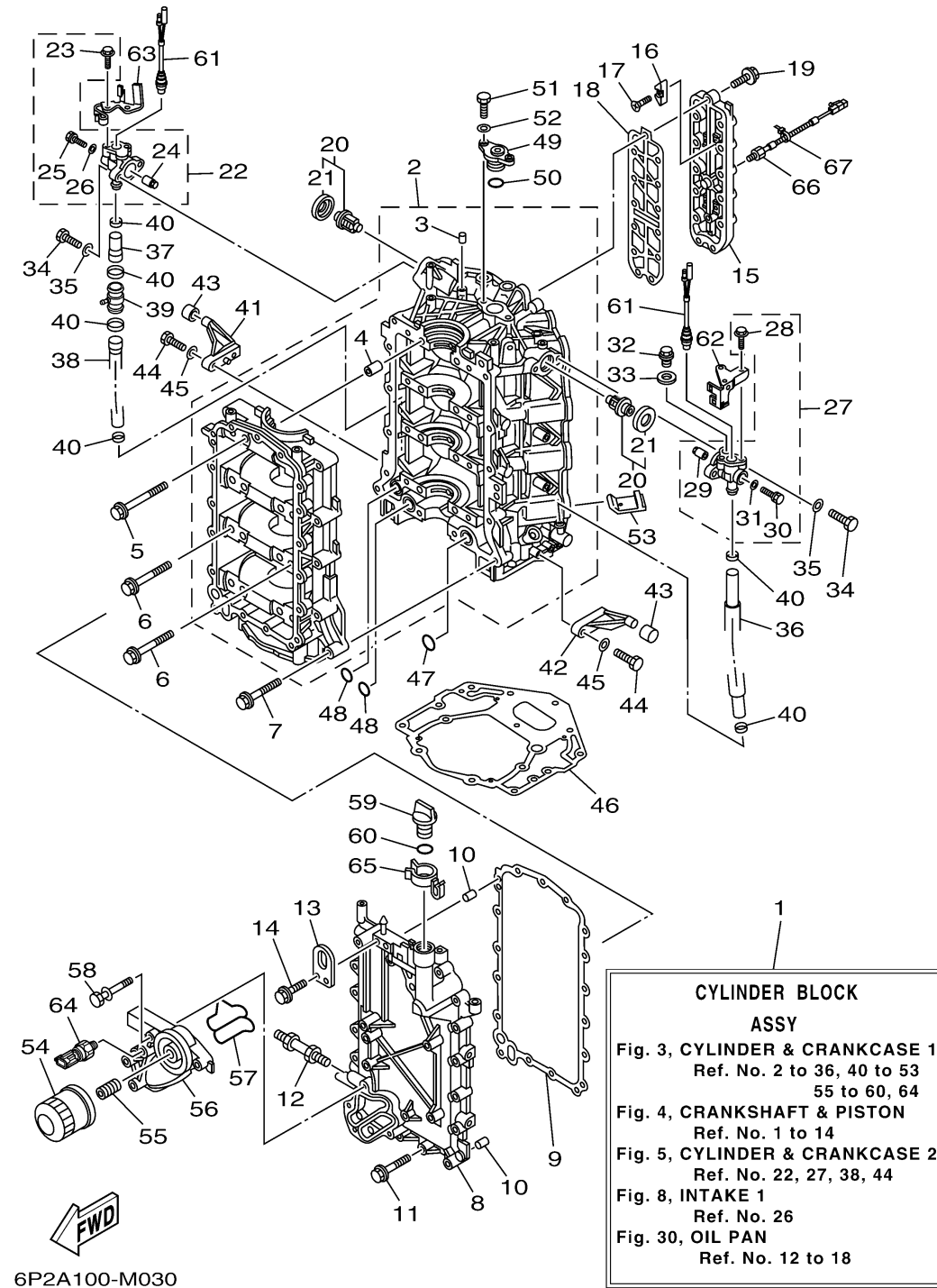

Ref No.	Part Number	Description	Qty	Remarks
40	90465-11M59-00	CLAMP	6	
41	67F-42761-01-00	STOPPER	1	
42	6P2-42761-00-00	STOPPER	1	
43	68F-44533-01-00	DAMPER, UPPER MOUNT RUBBER	2	
44	97095-06025-00	.BOLT	4	
45	92995-06600-00	WASHER	4	
46	69J-11351-11-00	.GASKET, CYLINDER	1	
47	93210-25552-00	O-RING	1	
48	93210-19MJ1-00	.O-RING	2	
49	69J-11313-00-00	PLUG, BLIND	1	
50	93210-25647-00	.O-RING	1	
51	97095-06020-00	BOLT	2	
52	92995-06600-00	WASHER	2	
53	69J-14664-00-00	.GROMMET, WATER SHUT	2	
54	69J-13440-01-00	ELEMENT ASSY, OIL CLEANER	1	
55	6S5-12858-00-00	BOLT, UNION	1	
56	6P2-13446-00-9S	CONNECTOR	1	
57	6P2-13477-00-00	.GASKET	1	
58	90119-06025-00	BOLT, WITH WASHER	5	
59	6G8-15363-00-00	PLUG, OIL	1	

CONTINUED ON NEXT FRAME >

CYLINDER CRANKCASE 1

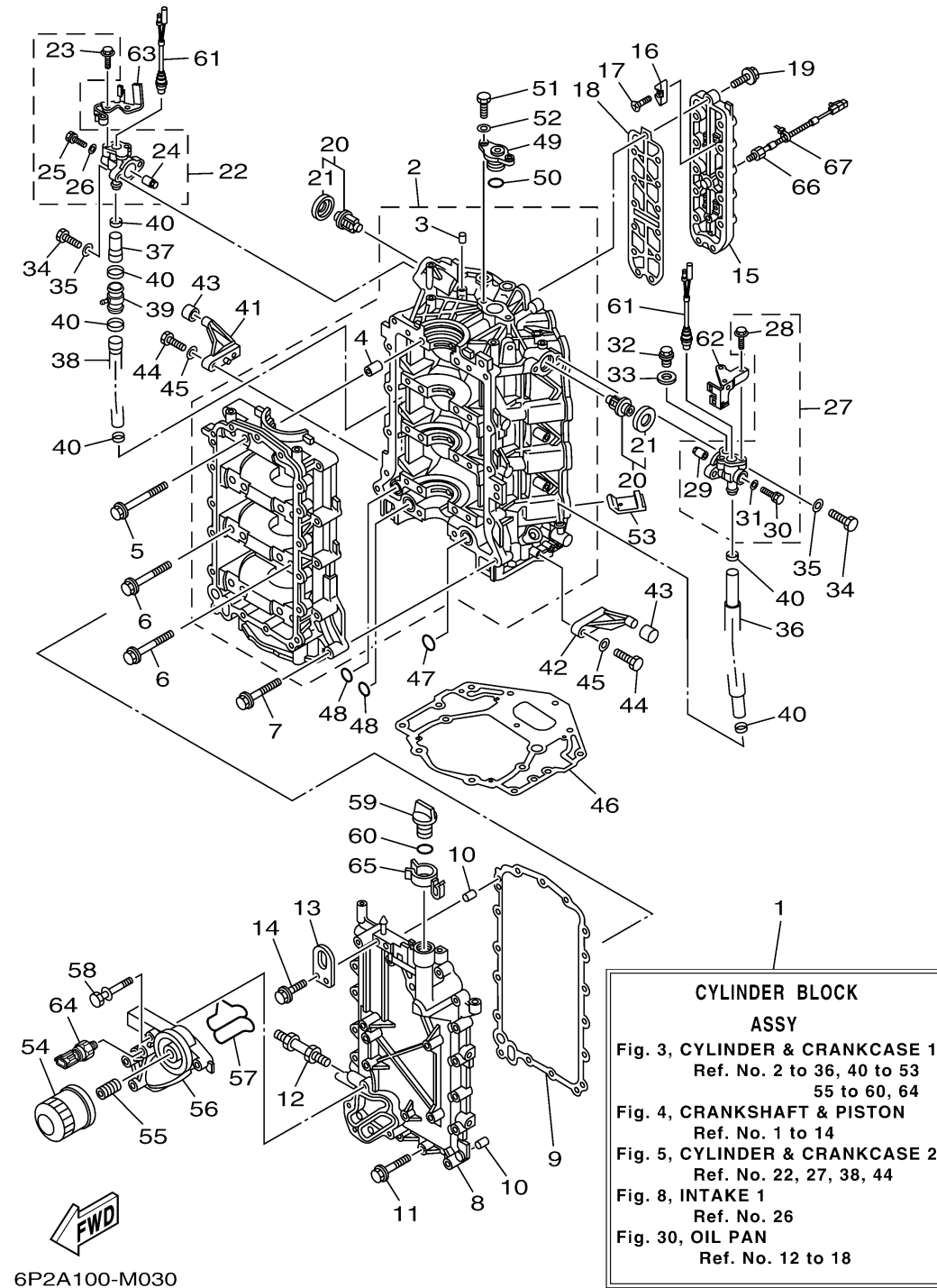

Ref No.	Part Number	Description	Qty	Remarks
60	93210-24M79-00	.O-RING	1	
61	6P2-82560-01-00	THERMO SWITCH ASSY	2	
62	6P2-82588-01-00	PLATE	1	
63	6P2-82389-00-00	PLATE 2	1	
64	6AW-83651-00-00	SENDER, OIL PRESSURE	1	
65	6P2-83597-00-00	CLAMP	1	
66	6P2-85780-00-00	SENSOR, KNOCK	1	
67	90465-11M10-00	.CLAMP	1	