

BOTTOM COWLING

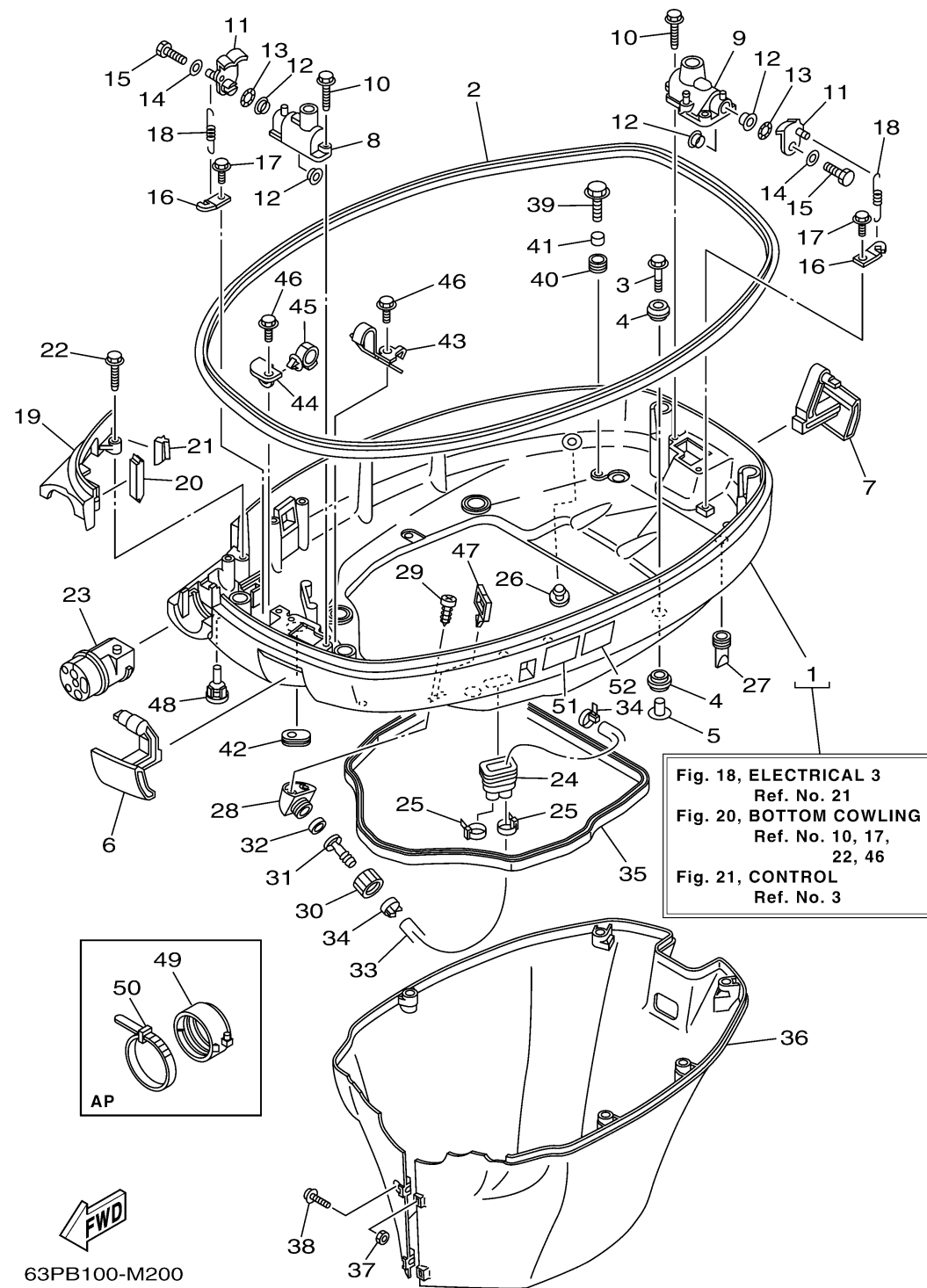

Ref No.	Part Number	Description	Qty	Remarks
1	63P-42710-01-8D	BOTTOM COWLING ASSY	1	
2	63P-42615-00-00	SEAL	1	
3	90119-08M22-00	BOLT, WITH WASHER	4	
4	90480-22M81-00	GROMMET	8	
5	90387-08M37-00	COLLAR	4	
6	63P-42815-00-8D	LEVER, CLAMP	1	
7	63P-42816-00-8D	LEVER, CLAMP	1	
8	68F-42828-03-9S	PLATE, CLAMP	1	
9	63P-42828-00-9S	PLATE, CLAMP	1	
10	90109-06M82-00	BOLT	4	
11	63P-42818-01-00	LEVER, CLAMP	2	
12	90386-15M73-00	BUSH	4	
13	90206-15M18-00	WASHER, WAVE	2	
14	90201-06068-00	WASHER, PLATE	2	
15	97095-06020-00	BOLT	2	
16	64D-43144-00-00	HOOK, SPRING	2	
17	90109-06M86-00	BOLT	2	
18	90506-16M34-00	SPRING, TENSION	2	
19	63P-42738-00-8D	PLATE, FITTING	1	
20	63P-42717-00-00	RUBBER, SEAL 2	1	

CONTINUED ON NEXT FRAME >

BOTTOM COWLING

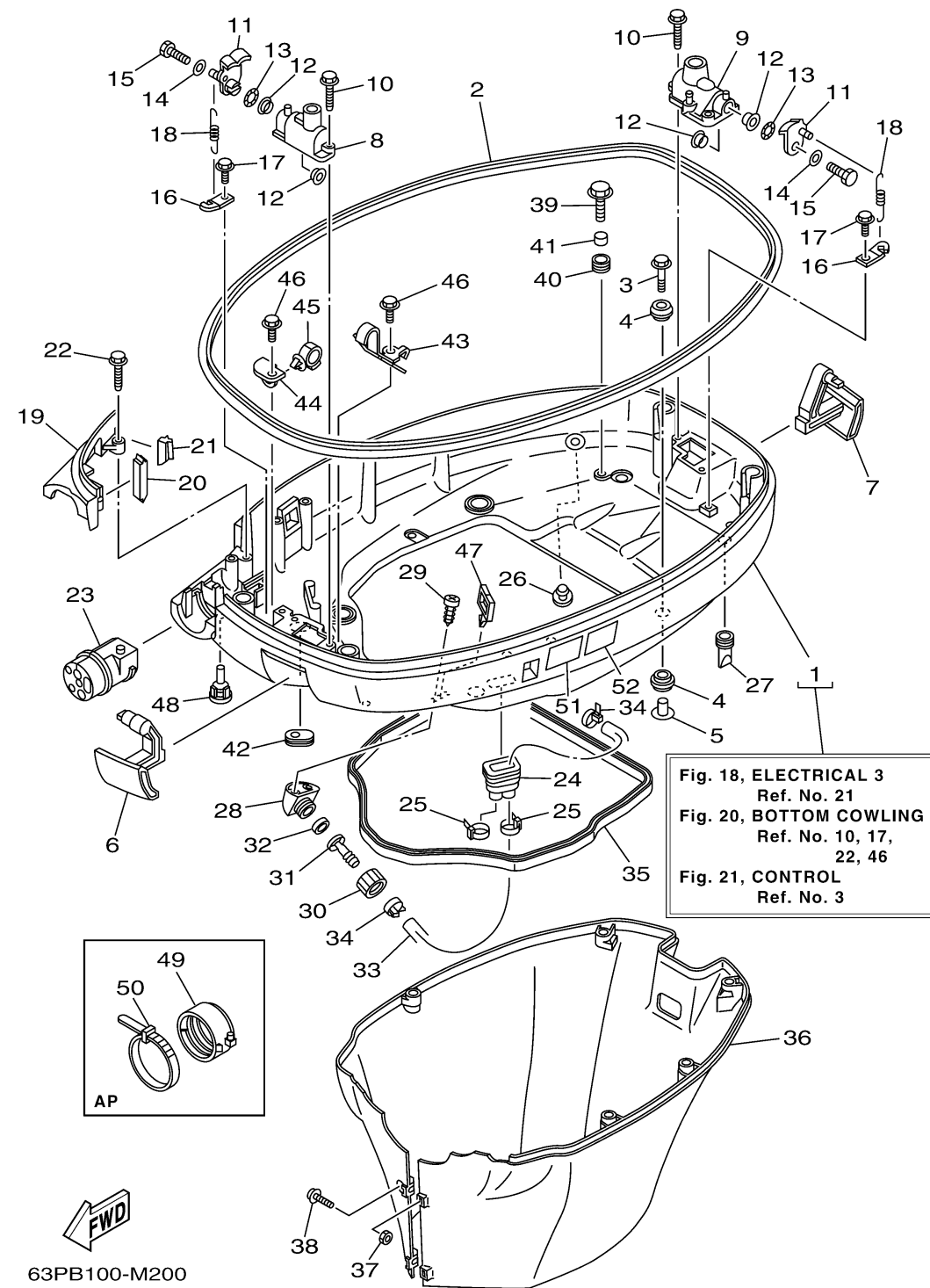

Ref No.	Part Number	Description	Qty	Remarks
21	63P-42718-00-00	RUBBER, SEAL 3	1	
22	90109-06M82-00	BOLT	2	
23	63P-42725-00-00	GROMMET	1	
24	6H1-42726-21-00	GROMMET	1	
25	90465-11M10-00	CLAMP	2	
26	6P2-44391-00-00	NIPPLE, HOSE	1	
27	61A-42717-00-00	RUBBER, SEAL 2	4	
28	68T-12572-00-00	ADAPTER	1	
29	97780-60520-00	SCREW, TAPPING	2	
30	6R3-12581-00-00	JOINT, HOSE 1	1	
31	6R3-12582-00-00	JOINT, HOSE 2	1	
32	6R3-12583-00-00	GASKET, HOSE JOINT	1	
33	63P-42541-00-00	PIPE 1	1	
34	90465-11M10-00	CLAMP	2	
35	63P-42716-00-00	RUBBER, SEAL 1	1	
36	63P-42741-01-8D	APRON	1	
37	95380-06600-00	NUT, HEXAGON	2	
38	90159-06M28-00	SCREW, WITH WASHER	2	
39	90109-06M80-00	BOLT	4	
40	90480-13M24-00	GROMMET	4	

CONTINUED ON NEXT FRAME >

BOTTOM COWLING

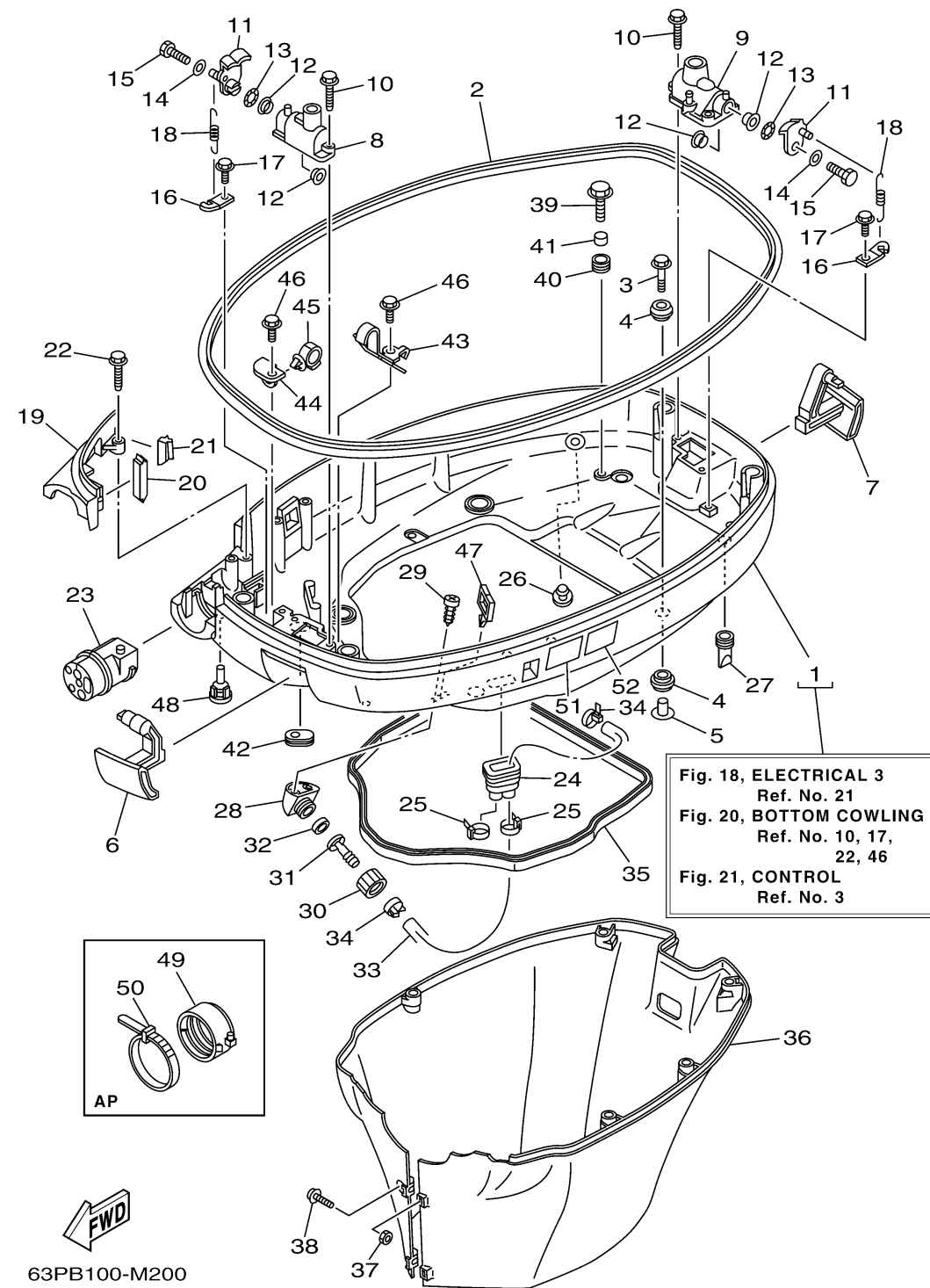

Ref No.	Part Number	Description	Qty	Remarks
41	90387-06M43-00	COLLAR	4	
42	61A-42727-00-00	GROMMET	1	
43	63P-42811-01-00	STAY	1	
44	63P-42756-00-00	STAY, CLAMP	1	
45	90464-20181-00	CLAMP	1	
46	90109-06M86-00	BOLT	2	
47	90464-23199-00	CLAMP	1	
48	6H4-42748-00-00	GROMMET	2	
49	68F-42753-00-00	FASTNER	1	AP
50	90464-20258-00	CLAMP	1	AP
51	6AH-42794-40-00	LABEL, WARNING (GENERAL)	1	
52	6AH-42794-50-00	LABEL, WARNING (GENERAL)	1	