

ELECTRICAL 3

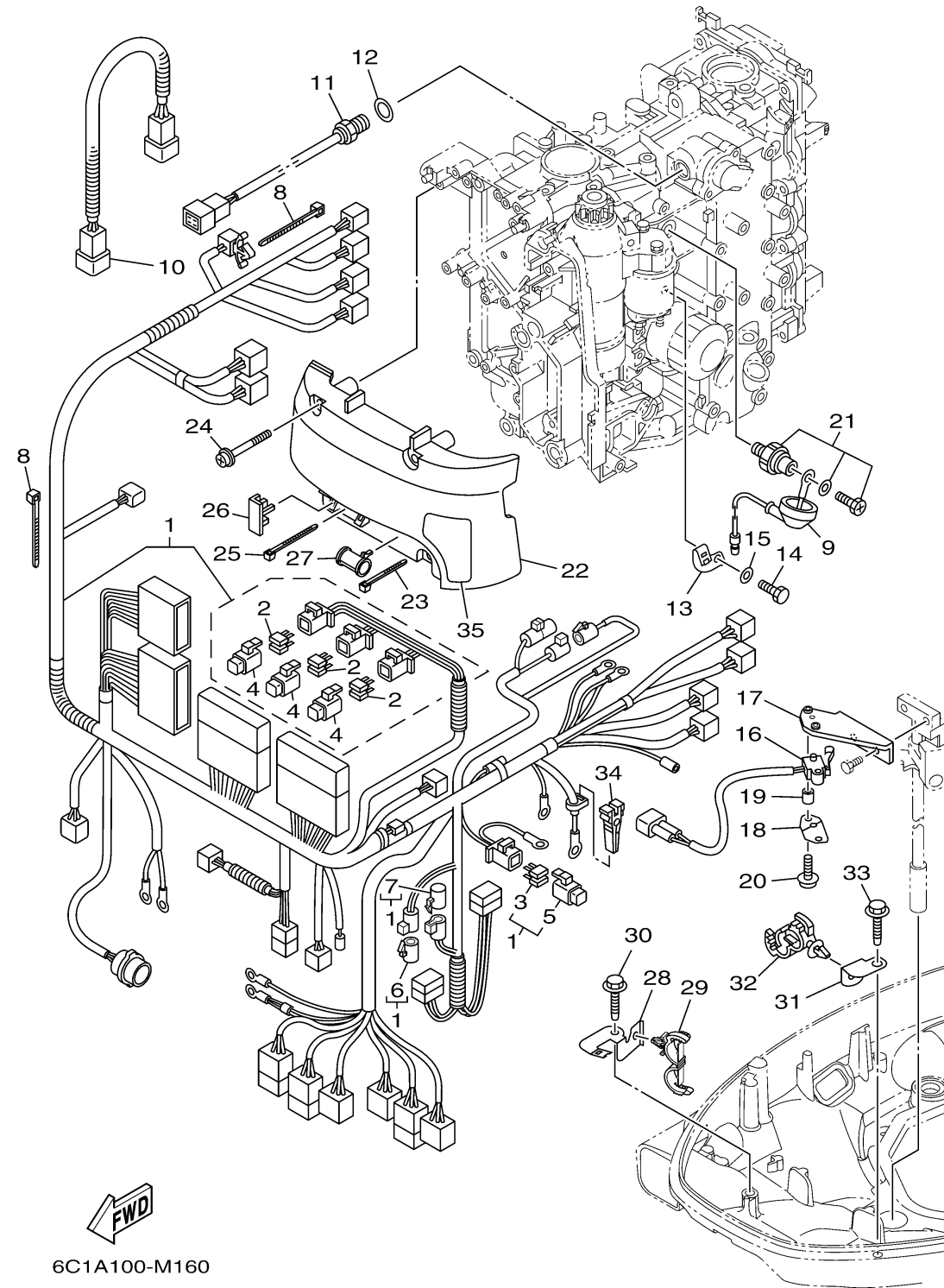

Ref No.	Part Number	Description	Qty	Remarks
1	6C5-82590-D0-00	WIRE HARNESS ASSY	1	FOR TILT LIMIT
2	67F-82151-00-00	..FUSE (20A)	6	
3	67F-82151-10-00	..FUSE (30A)	2	
4	67F-8215B-10-00	..CAP (YELLOW)	3	
5	67F-8215B-20-00	..CAP (GREEN)	1	
6	6DA-82582-00-00	..CAP 1 (FEMALE)	1	
7	6DA-82582-10-00	..CAP 1 (MALE)	1	
8	90465-13M11-00	CLAMP	2	
9	68V-81315-00-00	LEAD WIRE ASSY	1	
10	6C5-82553-00-00	EXTENSION, WIRE LEAD	1	
11	6CJ-85790-00-00	THERMOSENSOR ASSY	1	
12	90430-14115-00	..GASKET	1	
13	6C5-82388-10-00	PLATE	1	
14	97095-06014-00	BOLT	1	
15	92995-06600-00	WASHER	1	
16	60V-8259F-00-00	SWITCH ASSY	1	
17	6CJ-82554-00-00	STAY, NEUTRAL SWITCH	1	
18	61A-82588-01-00	PLATE	1	
19	90387-04001-00	COLLAR	1	
20	97985-04116-00	SCREW, WITH WASHER	2	

CONTINUED ON NEXT FRAME >

ELECTRICAL 3

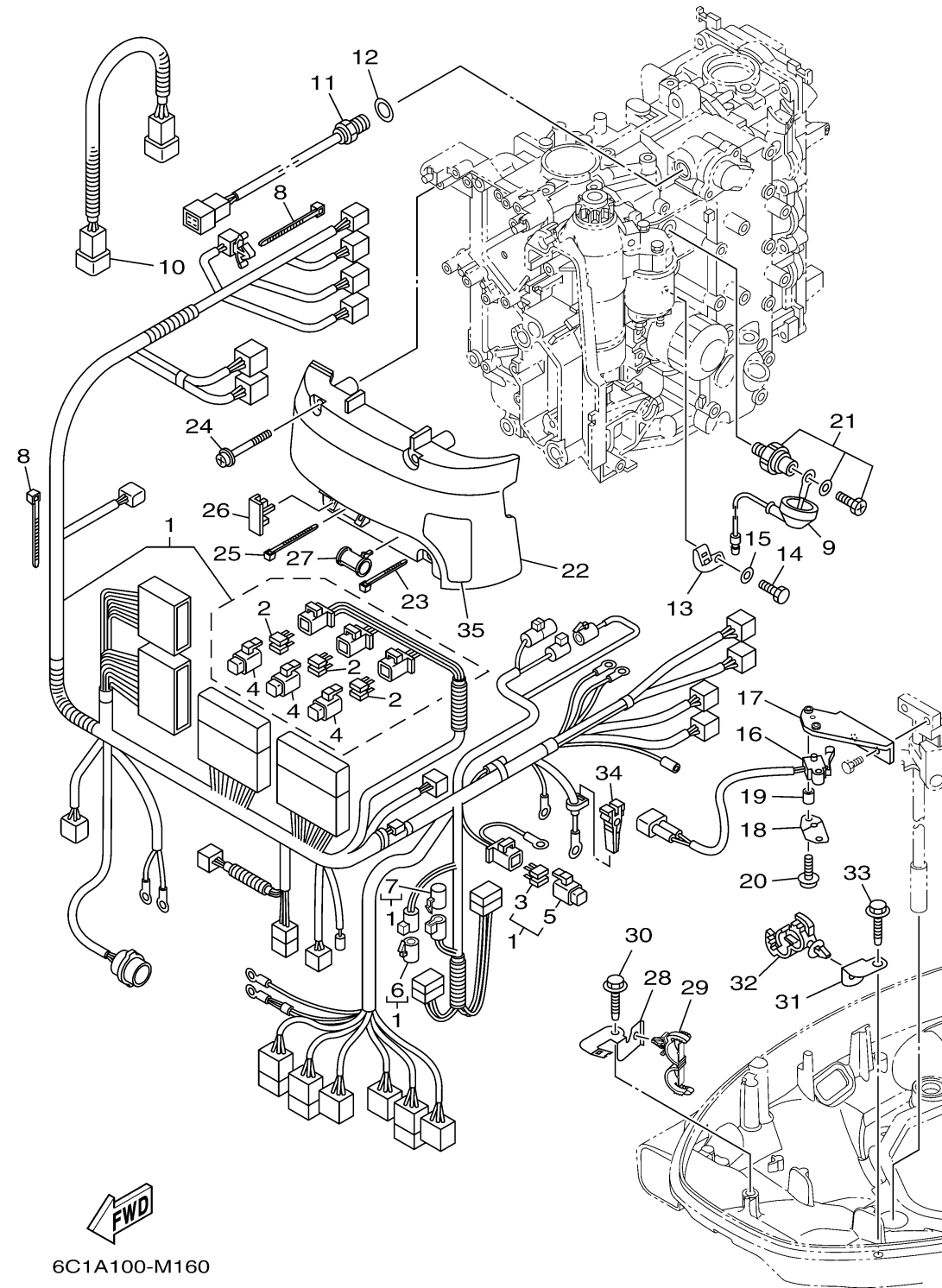

Ref No.	Part Number	Description	Qty	Remarks
21	64J-82504-00-00	OIL PRESSURE SWITCH ASSY	1	
22	6C5-81942-00-00	COVER	1	
23	90465-13M39-00	CLAMP	1	
24	90159-06M14-00	SCREW, WITH WASHER	4	
25	90465-13M24-00	CLAMP	1	
26	6C5-82176-00-00	DAMPER	2	
27	6C5-8252R-00-00	DAMPER	1	
28	6BG-42811-01-00	STAY	1	
29	90464-18205-00	CLAMP	1	
30	90109-06M86-00	BOLT	1	
31	63P-42756-00-00	STAY, CLAMP	1	
32	90464-12183-00	CLAMP	1	
33	90109-06M86-00	BOLT	1	
34	67F-2812A-00-00	.PULLER, FUSE	1	
35	6C5-81919-00-00	GRAPHIC, REGULATOR	1	