

OIL PAN

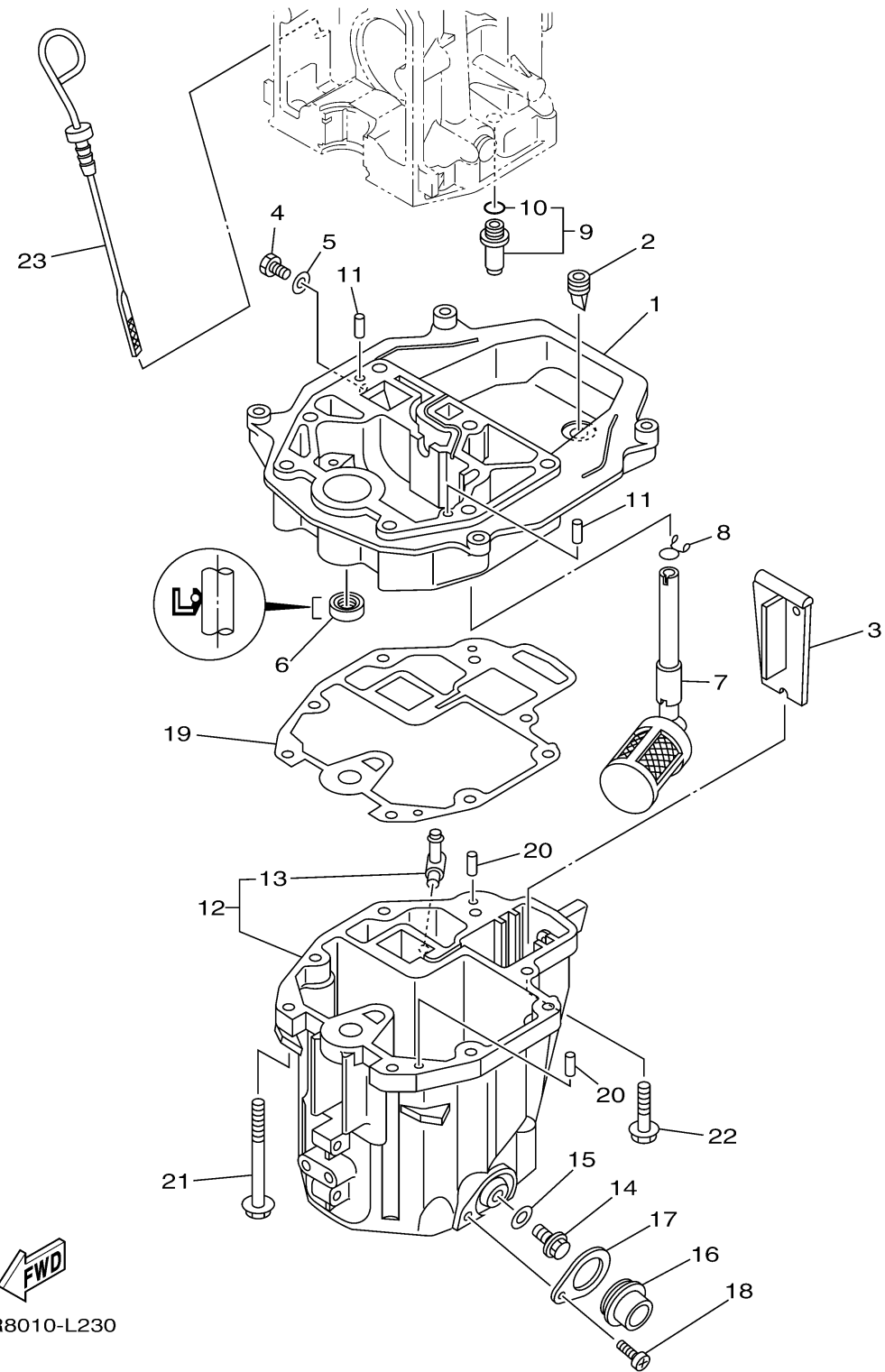

Ref No.	Part Number	Description	Qty	Remarks
1	60R-G1137-00-94	GUIDE, EXHAUST	1	
2	60S-G2717-00-00	RUBBER, SEAL 2	1	
3	60R-G5181-00-00	PLATE	1	
4	97095-08014-00	BOLT	1	
5	90430-08800-00	.GASKET	1	
6	93101-12M70-00	OIL SEAL	1	
7	68T-13421-01-00	STRAINER 2	1	
8	90467-11M08-00	CLIP	1	
9	6G8-11575-00-00	RELIEF VALVE ASSY	1	
10	93210-12M62-00	.O-RING	1	
11	93606-19M23-00	PIN, DOWEL	2	
12	60R-E5311-00-5B	OIL PAN	1	
13	6H1-11372-00-00	.NIPPLE, HOSE	1	
14	90340-10M10-00	PLUG, STRAIGHT SCREW	1	
15	90430-10M11-00	GASKET	1	
16	60R-E5316-00-00	DAMPER 1	1	
17	68T-15317-00-00	SPACER, ENGINE MOUNT	1	
18	97885-05008-00	SCREW, PAN HEAD	1	
19	68T-13475-00-00	.GASKET	1	
20	93604-12M07-00	PIN, DOWEL	2	

CONTINUED ON NEXT FRAME >

FWD
60R8010-L230

OIL PAN

Ref No.	Part Number	Description	Qty	Remarks
21	90119-08005-00	BOLT, WITH WASHER	6	
22	97575-08530-00	BOLT, WITH WASHER	2	
23	68T-15362-00-00	PLUG, OIL LEVEL	1	

