

ELECTRICAL 2

Ref No.	Part Number	Description	Qty	Remarks
1	63P-8591A-38-00	ENGINE CONTROL UNIT ASSY	1	
2	97095-06016-00	BOLT	4	
3	92995-06600-00	WASHER	4	
4	68V-8194A-00-00	RELAY	1	
5	68V-81953-00-00	STAY, RELAY	1	
6	97780-60620-00	SCREW, TAPPING	1	
7	97595-06610-00	BOLT, WITH WASHER	2	
8	6G5-82119-00-00	COVER, LEAD WIRE	2	
9	63P-81950-00-00	RELAY ASSY	1	
10	97595-06610-00	BOLT, WITH WASHER	2	
11	97013-06020-00	BOLT	2	
12	92903-06600-00	WASHER, PLATE	2	
13	63P-81948-00-00	BRACKET	1	
14	68F-85516-01-00	SPACER	3	
15	90387-06176-00	COLLAR	3	
16	68F-85119-00-00	BOLT	3	
17	90480-10627-00	GROMMET	1	
18	90464-23199-00	CLAMP	1	
19	90465-13M18-00	CLAMP	3	
20	68V-85548-01-00	HOLDER	1	

CONTINUED ON NEXT FRAME >

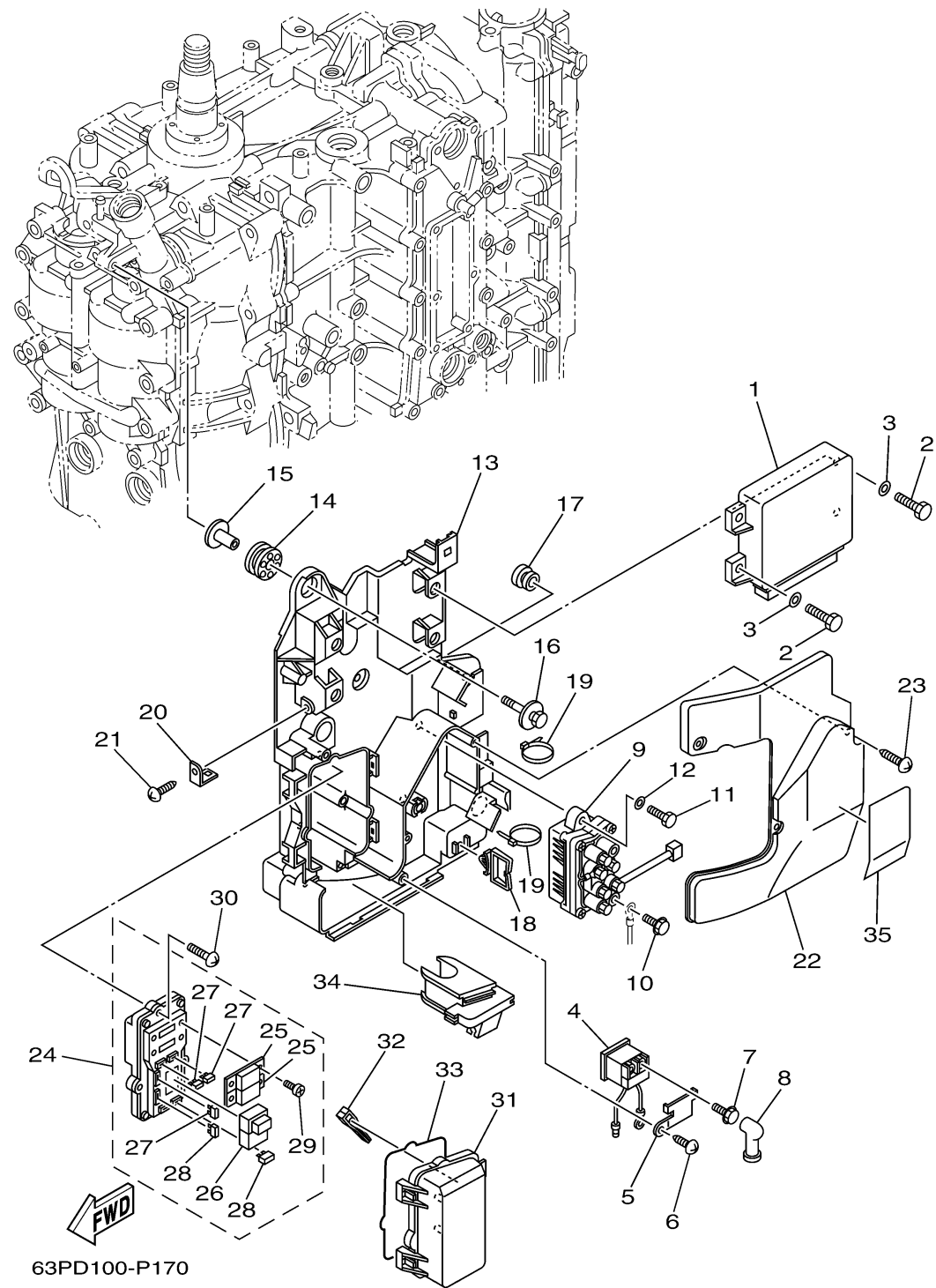

ELECTRICAL 2

Ref No.	Part Number	Description	Qty	Remarks
21	97780-60620-00	SCREW, TAPPING	1	
22	63P-81942-00-00	COVER	1	
23	90169-05M00-00	SCREW, TRUSS HEAD TAPPING	3	
24	63P-82170-02-00	FUSE BOX ASSY	1	
25	63P-82151-00-00	..FUSE (50A)	2	
26	6AW-8195A-00-00	..RELAY ASSY	1	
27	67F-82151-00-00	..FUSE (20A)	3	
28	67F-82151-10-00	..FUSE (30A)	2	
29	68F-82846-00-00	..SCREW, PAN HEAD (M5)	4	
30	97780-50620-00	SCREW, TAPPING	3	
31	60V-85544-00-00	CASE	1	
32	67F-2812A-00-00	PULLER, FUSE	1	
33	68F-82176-00-00	DAMPER	1	
34	63P-81336-00-00	GROMMET	1	
35	63P-81919-00-00	GRAPHIC, REGULATOR	1	