

OIL PAN

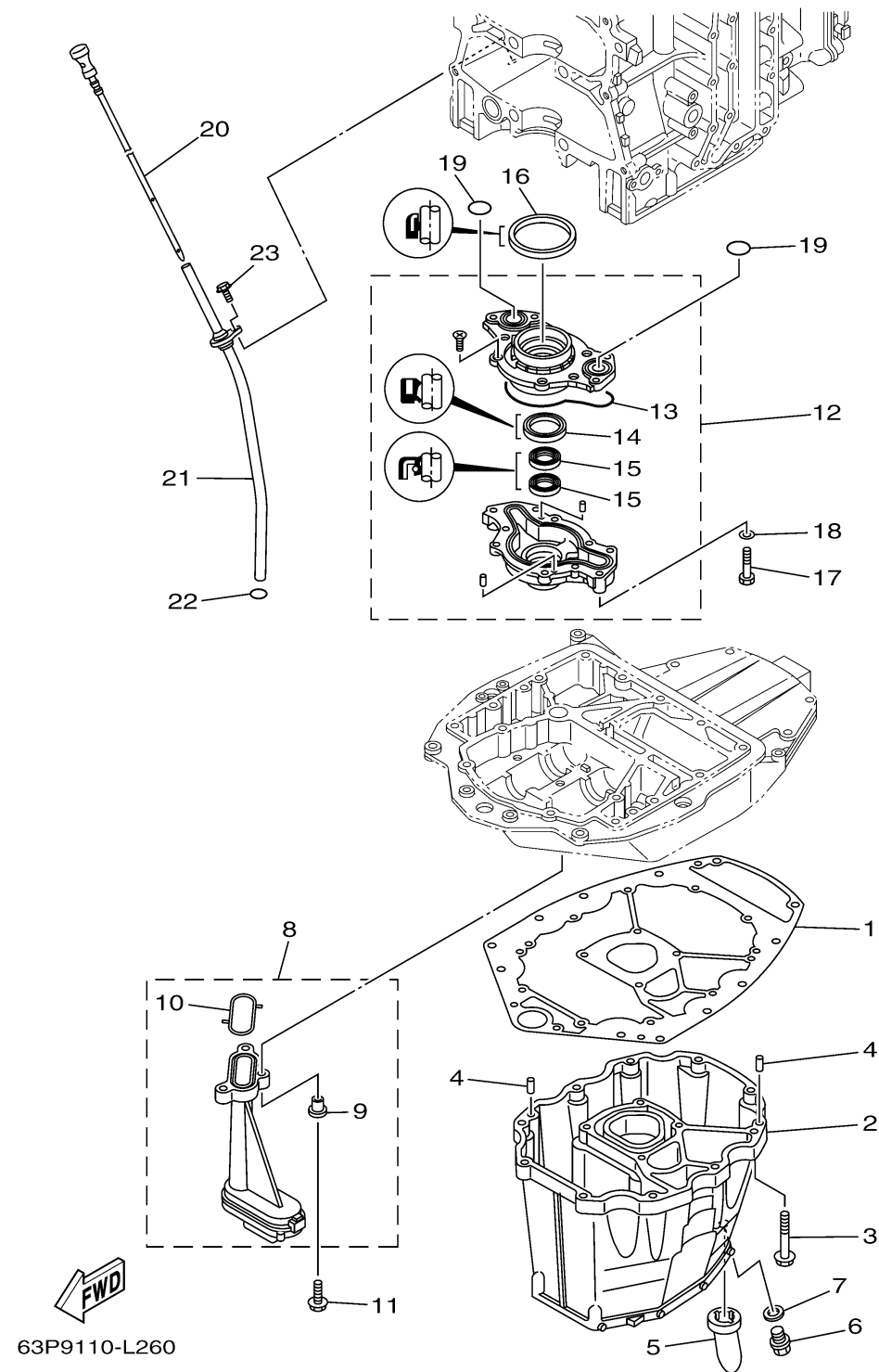

Ref No.	Part Number	Description	Qty	Remarks
1	63P-15312-01-00	.GASKET, OIL PAN	1	
2	63P-15311-02-CA	OIL PAN	1	
3	97575-08535-00	BOLT, WITH WASHER	10	
4	93608-16M16-00	PIN, DOWEL	2	
5	63P-15316-00-00	DAMPER 1	1	
6	90340-14M06-00	PLUG, STRAIGHT SCREW	1	
7	90430-14M09-00	.GASKET	1	
8	63P-13411-00-00	STRAINER, OIL	1	
9	90387-06263-00	. .COLLAR	3	
10	63P-13415-00-00	. .SEAL, OIL STRAINER	1	
11	95812-06025-00	BOLT, FLANGE	3	
12	63P-13300-02-00	OIL PUMP ASSY	1	
13	63P-13329-00-00	. .GASKET, PUMP COVER	1	
14	6AW-13119-00-00	. .OIL SEAL	1	
15	69J-13631-00-00	. .OIL SEAL	2	
16	69J-11355-00-00	.SEAL, CYLINDER 1	1	
17	97095-06040-00	.BOLT	4	
18	92995-06600-00	WASHER	4	
19	93210-25552-00	O-RING	2	
20	63P-15362-10-00	PLUG, OIL LEVEL	1	

CONTINUED ON NEXT FRAME >

OIL PAN

Ref No.	Part Number	Description	Qty	Remarks
21	63P-15377-10-00	GUIDE, INLET	1	
22	93210-19MJ3-00	.O-RING	1	
23	95895-06016-00	BOLT, FLANGE	1	

