

POWER TRIM TILT ASSY 2

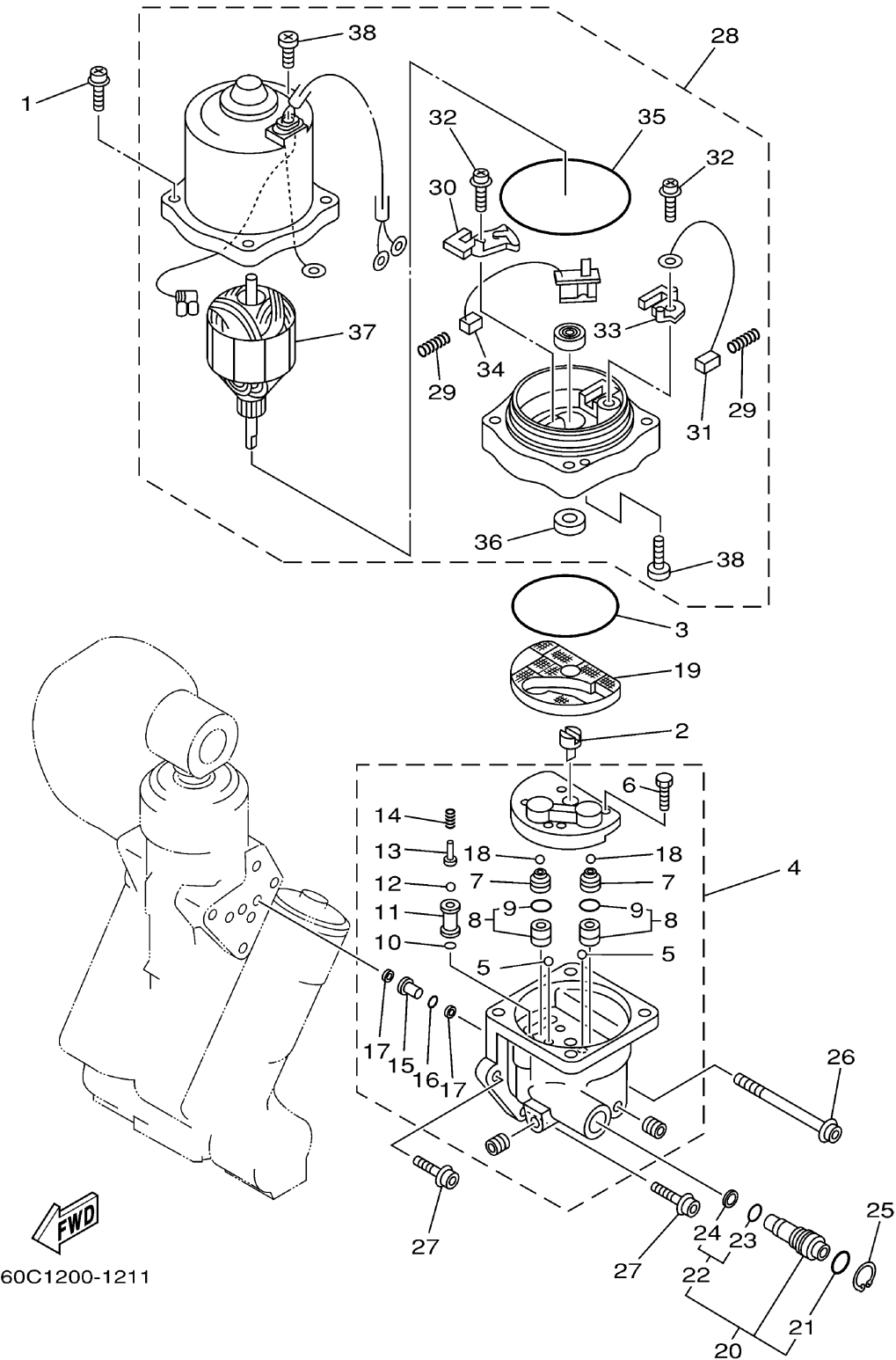

60C1200-1211

Ref No.	Part Number	Description	Qty	Remarks
1	64E-4388E-11-00	BOLT ,SCREW (L:34.7MM)	4	
2	64E-43831-00-00	CONNECTOR, SHAFT	1	
3	64E-43868-00-00	O-RING	1	
4	64E-43830-01-00	GEAR PUMP ASSY	1	
5	72X-43858-00-00	..BALL	2	
6	64E-43843-00-00	..SCREW, VALVE LOCK	4	
7	6AW-43841-00-00	..PISTON, SHUTTLE	2	
8	64E-43802-00-00	..VALVE SUB ASSY	2	
9	6E5-43896-00-00	...O-RING	1	
10	6G5-43863-00-00	..O-RING	1	
11	64E-43851-00-00	..SEAT, RELIEF VALVE	1	
12	64E-43858-00-00	..BALL	1	
13	64E-43859-00-00	..PIN, VALVE SUPPORT	1	
14	64E-43855-00-00	..SPRING, UP RELIEF	1	
15	64E-43850-00-00	..VALVE SUB ASSY	1	
16	64E-43865-00-00	..O-RING	1	
17	64E-43816-00-00	..FILTER 1	2	
18	6AW-43858-00-00	..BALL	2	
19	64E-43817-11-00	FILTER 2	1	
20	64E-43860-01-00	MANUAL VALVE SUB-ASSY	1	

CONTINUED ON NEXT FRAME >

POWER TRIM TILT ASSY 2

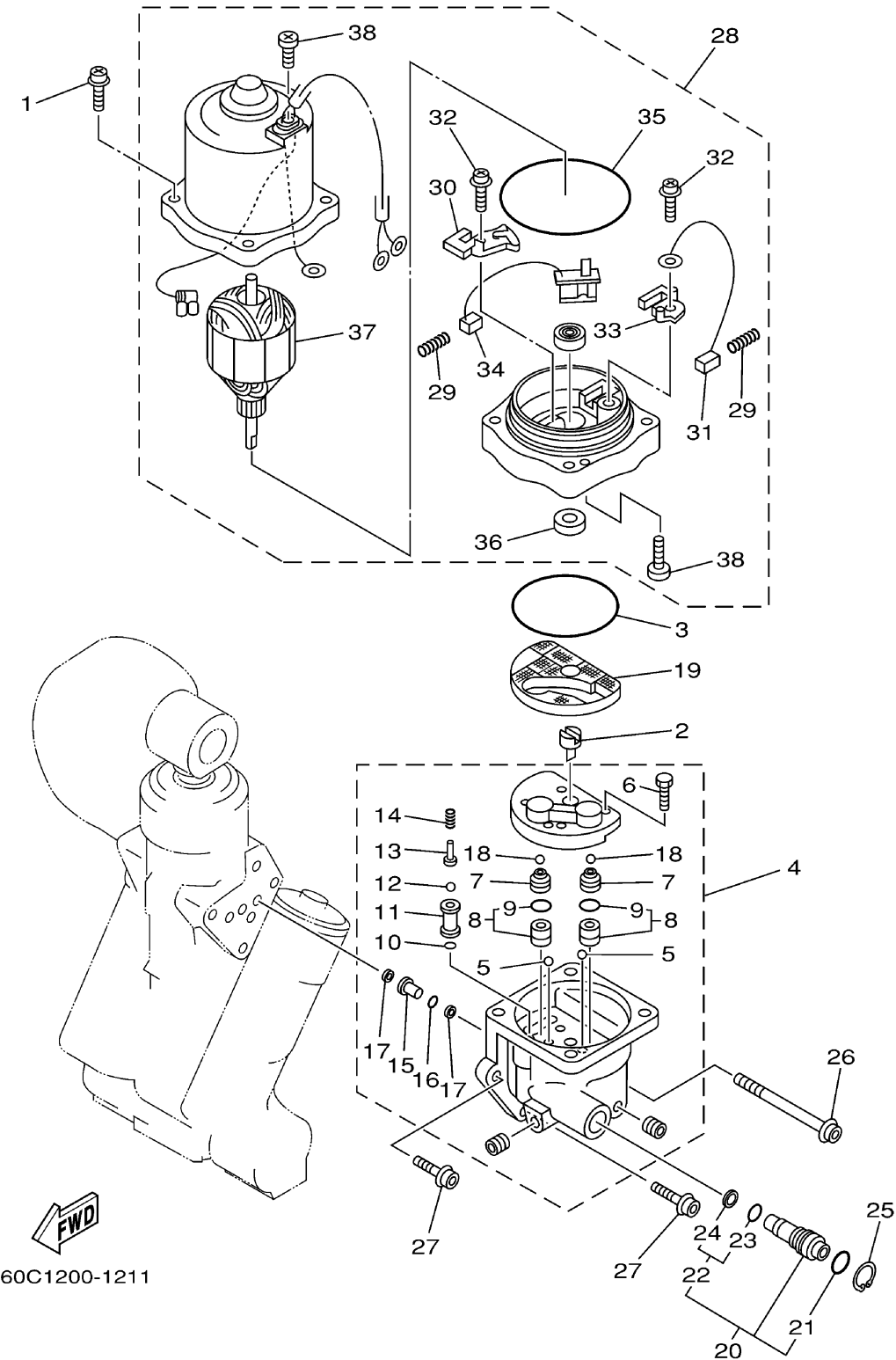

Ref No.	Part Number	Description	Qty	Remarks
21	72X-85075-L0-00	..O-RING	1	
22	64E-43827-00-00	..RING SET	1	
23	64E-4387A-00-00	...O-RING	1	
24	64E-43873-00-00	...RING, BACK UP	1	
25	6AW-43875-00-00	RING, SNAP	1	
26	64E-43879-11-00	SCREW, WITH WASHER	1	
27	64E-43879-01-00	SCREW, WITH WASHER	2	
28	67H-43880-04-00	MOTOR ASSY	1	
29	6H1-4386K-10-00	..SPRING, BRUSH	2	
30	64E-4380J-00-00	..HOLDER, BRUSH	1	
31	64E-43891-00-00	..BRUSH 1	1	
32	97607-04310-00	..SCREW, WITH WASHER	2	
33	64E-4380F-00-00	..HOLDER, BRUSH 2	1	
34	64E-43892-00-00	..BREAKER COMP. (BRUSH 2)	1	
35	6G5-43865-01-00	..O-RING	1	
36	93102-08M43-00	..OIL SEAL	1	
37	64E-43805-01-00	..ARMATURE ASSY	1	
38	64E-43843-10-00	..SCREW, VALVE LOCK	3	