

ELECTRICAL 4

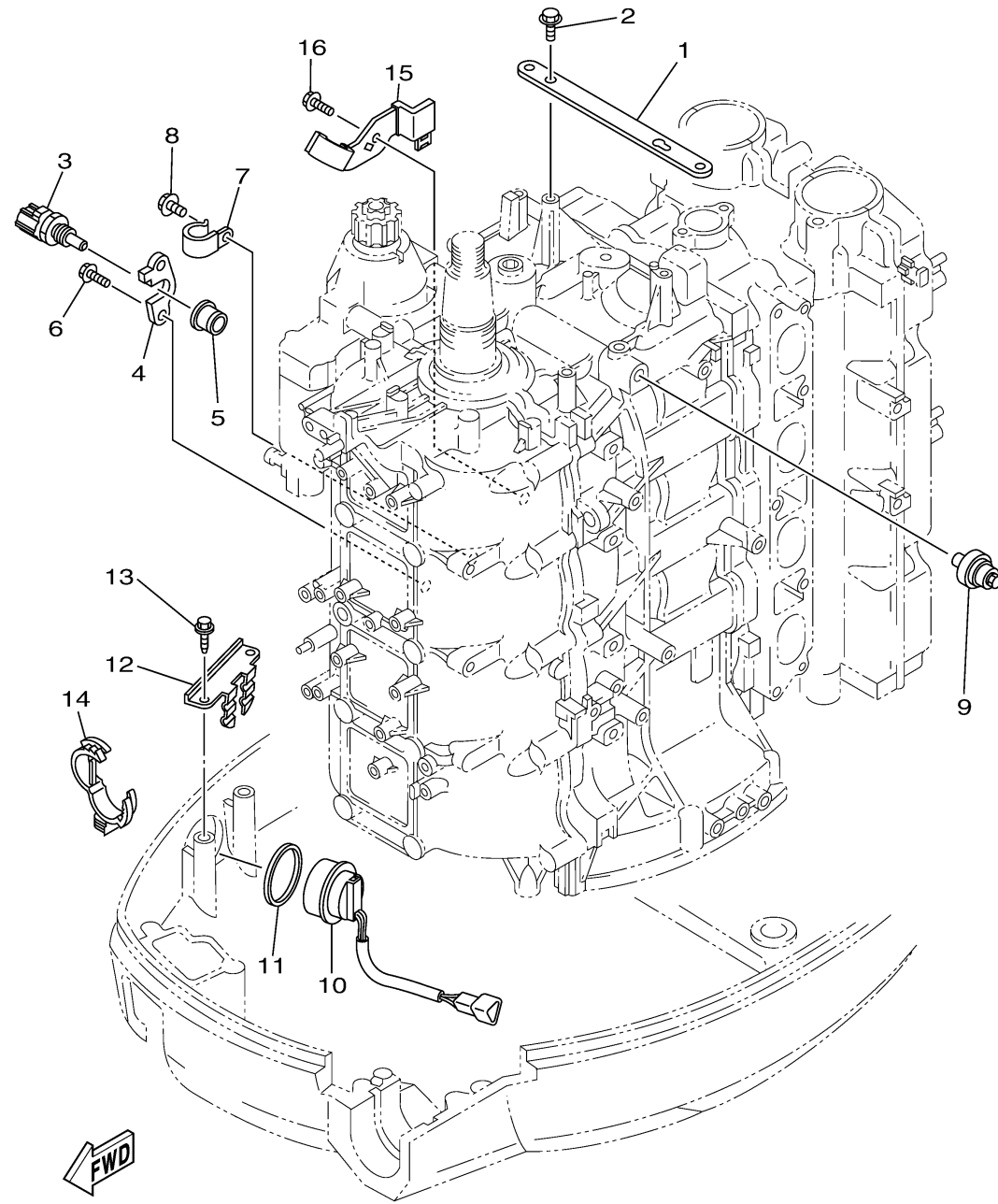

6D6C100-P170

Ref No.	Part Number	Description	Qty	Remarks
1	6D8-8132G-10-00	PLATE	1	
2	97595-06516-00	BOLT, WITH WASHER	2	
3	6D8-85790-00-00	THERMOSENSOR ASSY	1	
4	67F-85757-00-00	RETAINER	1	
5	68V-85753-00-00	.GASKET, SENDER UNIT	1	
6	97595-06516-00	BOLT, WITH WASHER	2	
7	90465-06M86-00	CLAMP	1	
8	97595-06512-00	BOLT, WITH WASHER	1	
9	68V-82504-00-00	OIL PRESSURE SWITCH ASSY	1	
10	63D-82563-11-00	TRIM & TILT SWITCH ASSY	1	
11	6E5-82587-00-00	GASKET	1	
12	67F-83614-00-00	BRACKET	1	
13	90109-06M86-00	BOLT	2	
14	90464-30003-00	CLAMP	2	
15	6D8-8252H-01-00	PLATE, HOLDER	1	
16	97595-06512-00	BOLT, WITH WASHER	1	