

# OIL PAN

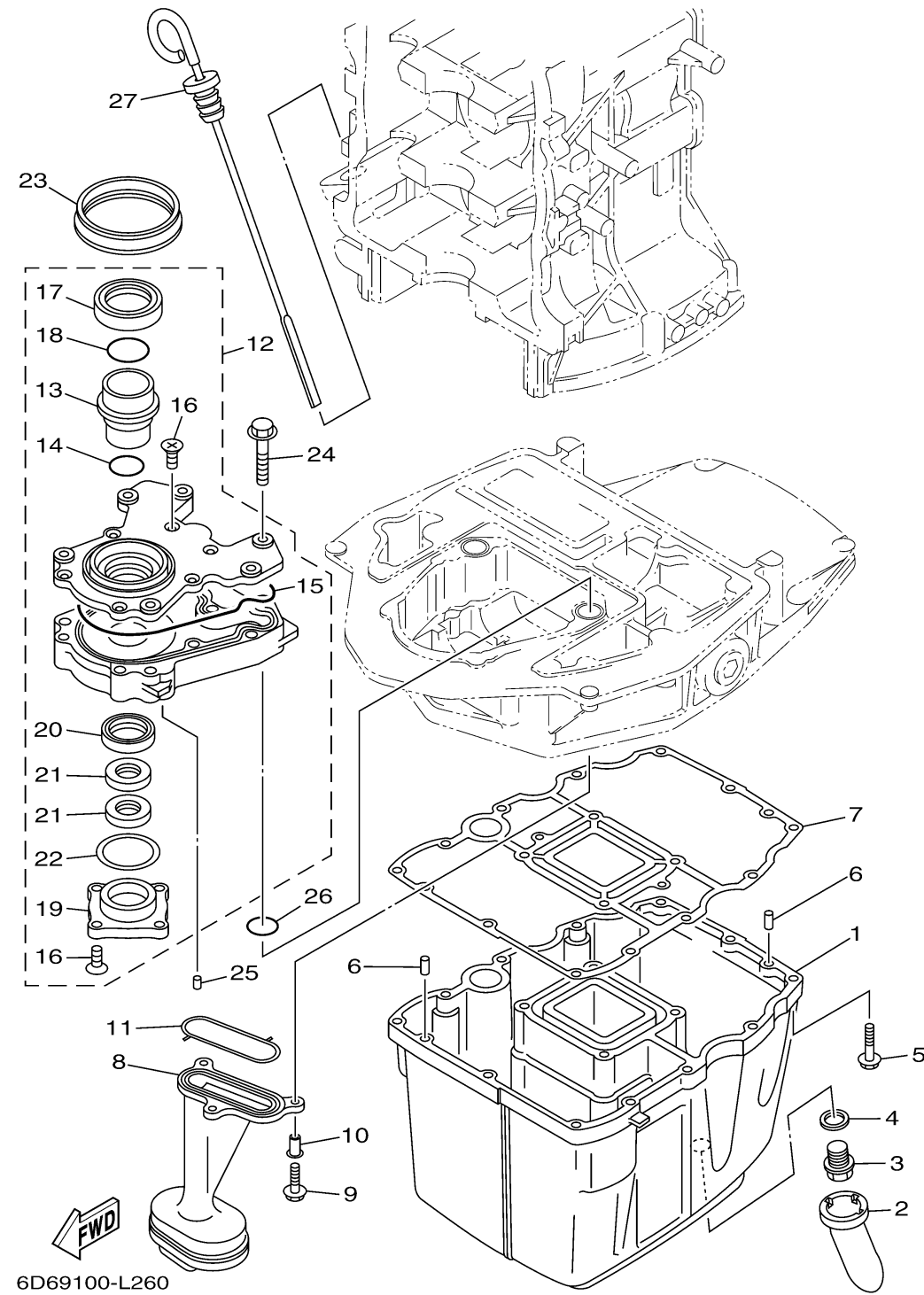

Ref No.	Part Number	Description	Qty	Remarks
1	67F-15311-03-CA	OIL PAN	1	
2	63P-15316-00-00	DAMPER 1	1	
3	90340-14M06-00	PLUG, STRAIGHT SCREW	1	
4	90430-14M09-00	.GASKET	1	
5	97575-06525-00	BOLT, WITH WASHER	12	
6	93606-12019-00	.PIN, DOWEL	2	
7	68V-15312-00-00	.GASKET, OIL PAN	1	
8	67F-13411-00-00	STRAINER, OIL	1	
9	95812-06025-00	BOLT, FLANGE	3	
10	90387-06263-00	.COLLAR	3	
11	67F-13415-00-00	.SEAL, OIL STRAINER	1	
12	67F-13300-10-00	OIL PUMP ASSY	1	
13	67F-13314-02-00	.SHAFT, PUMP	1	
14	67F-13473-01-00	.O-RING	1	
15	67F-13329-00-00	.GASKET, PUMP COVER	1	
16	67F-13495-00-00	.SCREW	10	
17	67F-13119-01-00	.OIL SEAL	1	
18	67F-13769-00-00	.O-RING	1	
19	67F-13914-00-00	.HOUSING, PUMP	1	
20	67F-13631-03-00	.OIL SEAL	1	

CONTINUED ON NEXT FRAME >

# OIL PAN

Ref No.	Part Number	Description	Qty	Remarks
21	67F-13149-00-00	. .OIL SEAL	2	
22	67F-13339-00-00	. .GASKET, PUMP COVER	1	
23	67F-13338-00-00	SEAL	1	
24	97595-06545-00	BOLT, WITH WASHER	6	
25	93604-12M07-00	PIN, DOWEL	2	
26	93210-19MJ1-00	.O-RING	2	
27	6D8-15362-00-00	PLUG, OIL LEVEL	1	

