

6FM2100DS130

*1: CUT FROM 50M ROLLS (PART NO. 90790-48193), CUTTING LENGTH: 1.95M

STARTER

Ref No.	Part Number	Description	Qty	Remarks
1	6FM-15710-02-00	STARTER ASSY	1	
2	6FM-15711-01-00	..CASE, STARTER	1	
3	6FM-15764-00-00	...COLLAR 1	3	
4	6AH-15795-00-00	...GUIDE, ROPE	1	
5	63V-15713-00-00	..SPRING, STARTER	1	
6	6FM-15714-01-00	..DRUM, SHEAVE	1	
7	6FM-15741-00-00	..PAWL, DRIVE	2	
8	6FM-15734-00-00	..SPRING, RETURN	2	
9	6FM-15705-00-00	..SPRING, DRIVE PAWL	1	
10	6FM-15735-01-00	..GUIDE, CAM	1	
11	6FM-15726-00-00	..WASHER, FLAT	1	
12	6FM-15793-00-00	..SCREW	1	
13	6G1-15755-00-00	..HANDLE, STARTER	1	
15	6G1-15779-00-00	..COVER	1	
16	6A0-15789-00-00	..DAMPER	1	
17	6FM-15721-00-00	..SHIM	1	
18	6FM-15753-00-00	..BUSH	1	
19	6FM-15752-00-00	..ROLLER, WIRE	1	
20	6FM-15768-00-00	..BOLT	1	
21	63V-15794-00-00	..STOPPER	1	

CONTINUED ON NEXT FRAME >

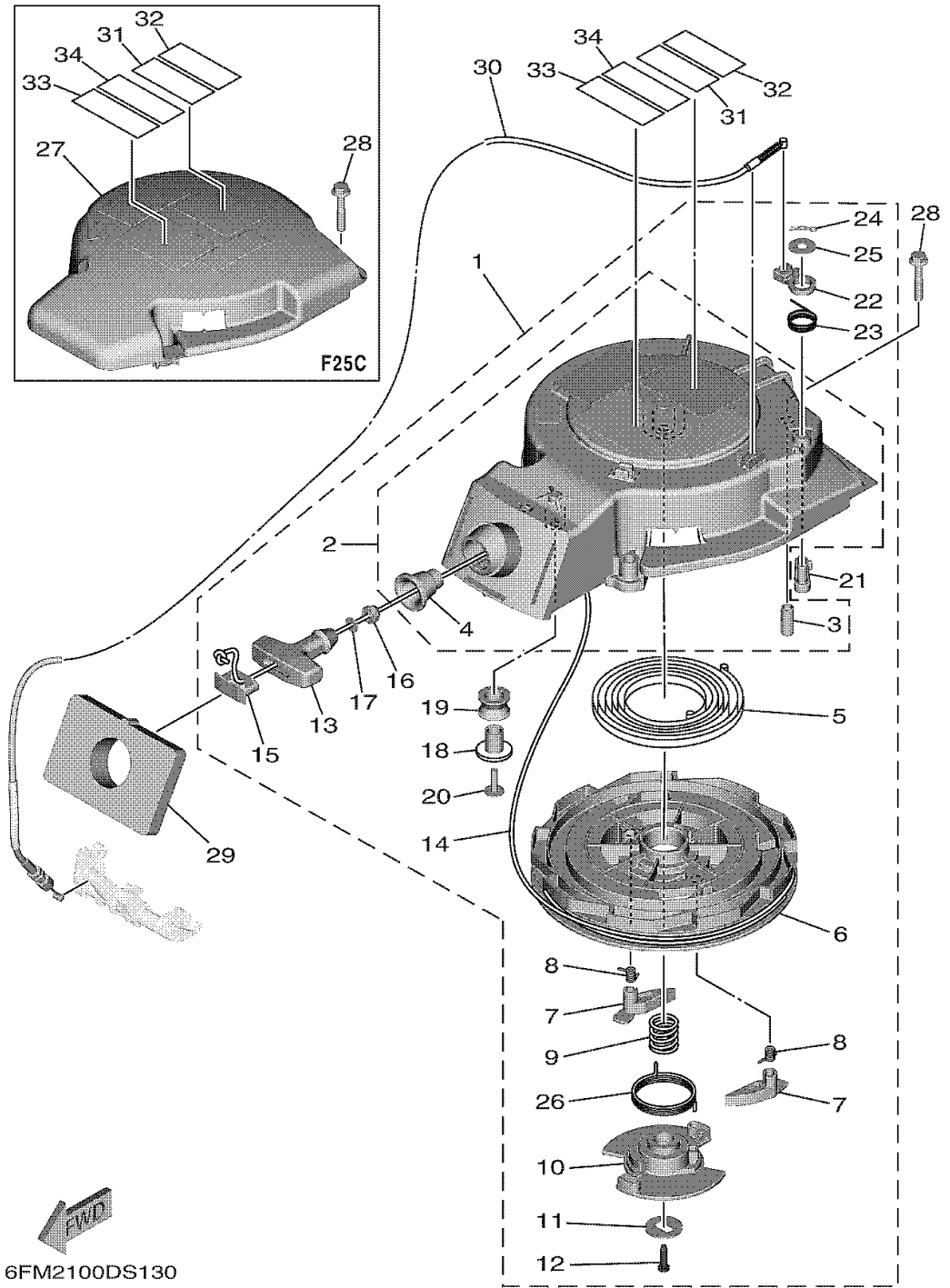

*1: CUT FROM 50M ROLLS (PART NO. 90790-48193), CUTTING LENGTH: 1.95M

STARTER

Ref No.	Part Number	Description	Qty	Remarks
22	6FM-15748-00-00	. .PLUNGER, STARTER STOP	1	
23	63V-15734-00-00	. .SPRING, RETURN	1	
24	6FM-15799-01-00	. .CLIP	1	
25	63V-15726-00-00	. .WASHER, FLAT	1	
26	6FM-15767-00-00	. .SPRING	1	
27	6FM-81337-00-00	COVER, FLYWHEEL	0	
28	97595-06520-00	BOLT, WITH WASHER	0	
28	90105-06035-00	BOLT, FLANGE	3	
29	6FM-15762-00-00	SEAL, RUBBER 2	1	
30	6FM-15770-08-00	CABLE COMP., STARTER STOP	1	
31	6EE-81995-40-00	LABEL, WARNING	1	
32	6EE-81995-50-00	LABEL, WARNING	1	
33	6EE-81994-40-00	LABEL, SAFETY	1	
34	6EE-81994-50-00	LABEL, SAFETY	1	