

CRANKSHAFT PISTON

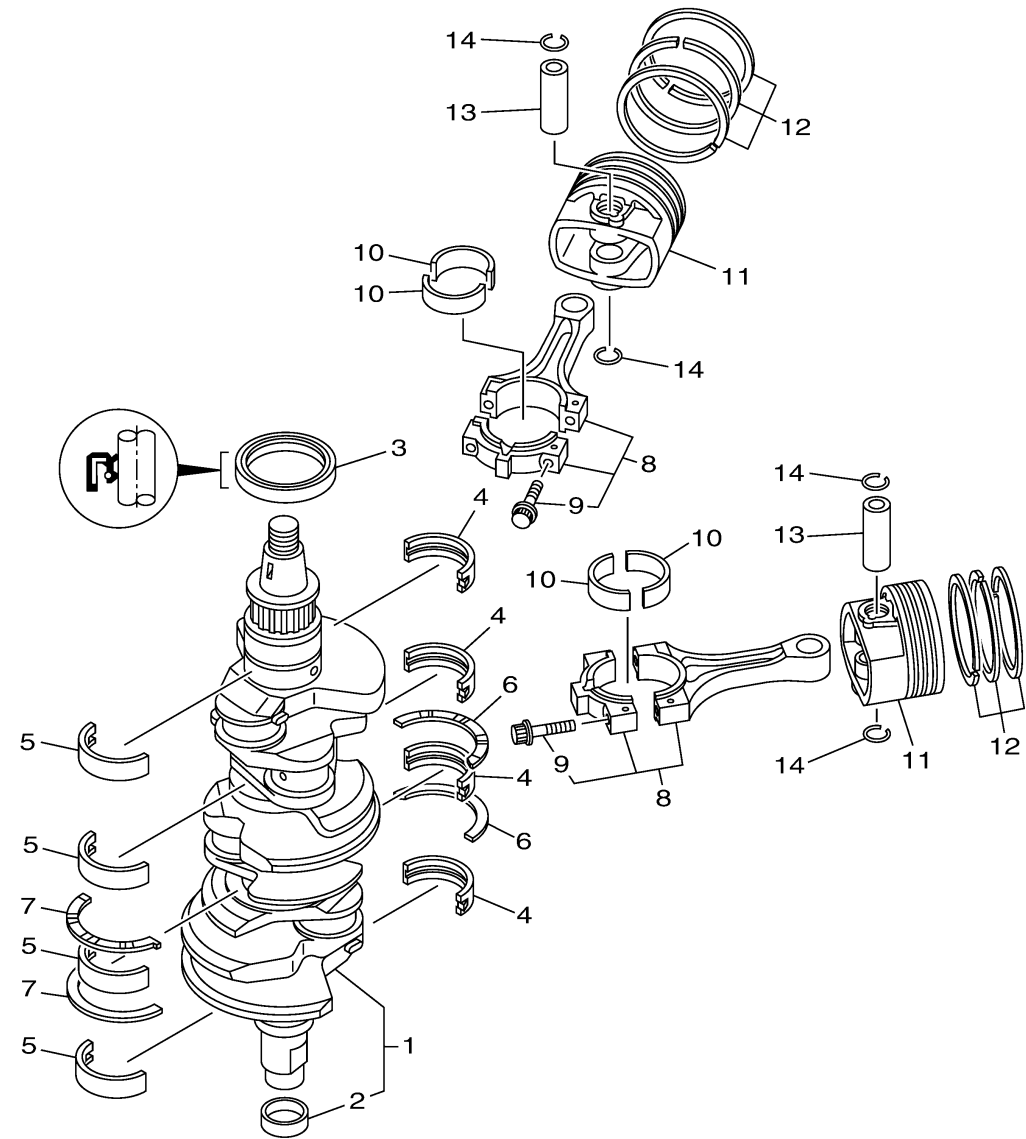

Ref No.	Part Number	Description	Qty	Remarks
1	6P2-11410-10-00	CRANKSHAFT	1	
2	6CB-11478-00-00	. .COLLAR	1	
3	93102-63004-00	.OIL SEAL	1	
4	6P2-11416-10-00	PLANE BEARING, CRANKSHAFT 1	4	UR GREEN
4	6P2-11416-20-00	PLANE BEARING, CRANKSHAFT 1	4	UR BLUE
4	6P2-11416-00-00	PLANE BEARING, CRANKSHAFT 1	4	UR YELLOW
5	6P2-11417-10-00	PLANE BEARING, CRANKSHAFT 2	4	UR GREEN
5	6P2-11417-20-00	PLANE BEARING, CRANKSHAFT 2	4	UR BLUE
5	6P2-11417-00-00	PLANE BEARING, CRANKSHAFT 2	4	UR YELLOW
6	6AW-11426-01-00	BEARING, THRUST 1	2	
7	6AW-11427-01-00	BEARING, THRUST 2	2	
8	6P2-11650-00-00	CONNECTING ROD ASSY	6	
9	63P-11654-10-00	. .BOLT, CONNECTING ROD	2	
10	6P2-11656-20-00	PLANE BEARING, CONNECTING ROD	12	UR BLUE
10	6P2-11656-00-00	PLANE BEARING, CONNECTING ROD	12	UR YELLOW
10	6P2-11656-10-00	PLANE BEARING, CONNECTING ROD	12	UR GREEN
11	6P2-11635-10-00	PISTON (0.25MM O/S)	6	AP
11	6P2-11631-10-93	PISTON (STD)	6	
12	63P-11603-01-00	PISTON RING SET (STD)	6	
12	63P-11604-00-00	PISTON RING SET (0.25MM O/S)	6	AP

CONTINUED ON NEXT FRAME >

6ALB100-P040

CRANKSHAFT PISTON

Ref No.	Part Number	Description	Qty	Remarks
13	63P-11633-10-00	PIN, PISTON	6	
14	63P-11634-00-00	CLIP, PISTON PIN	12	

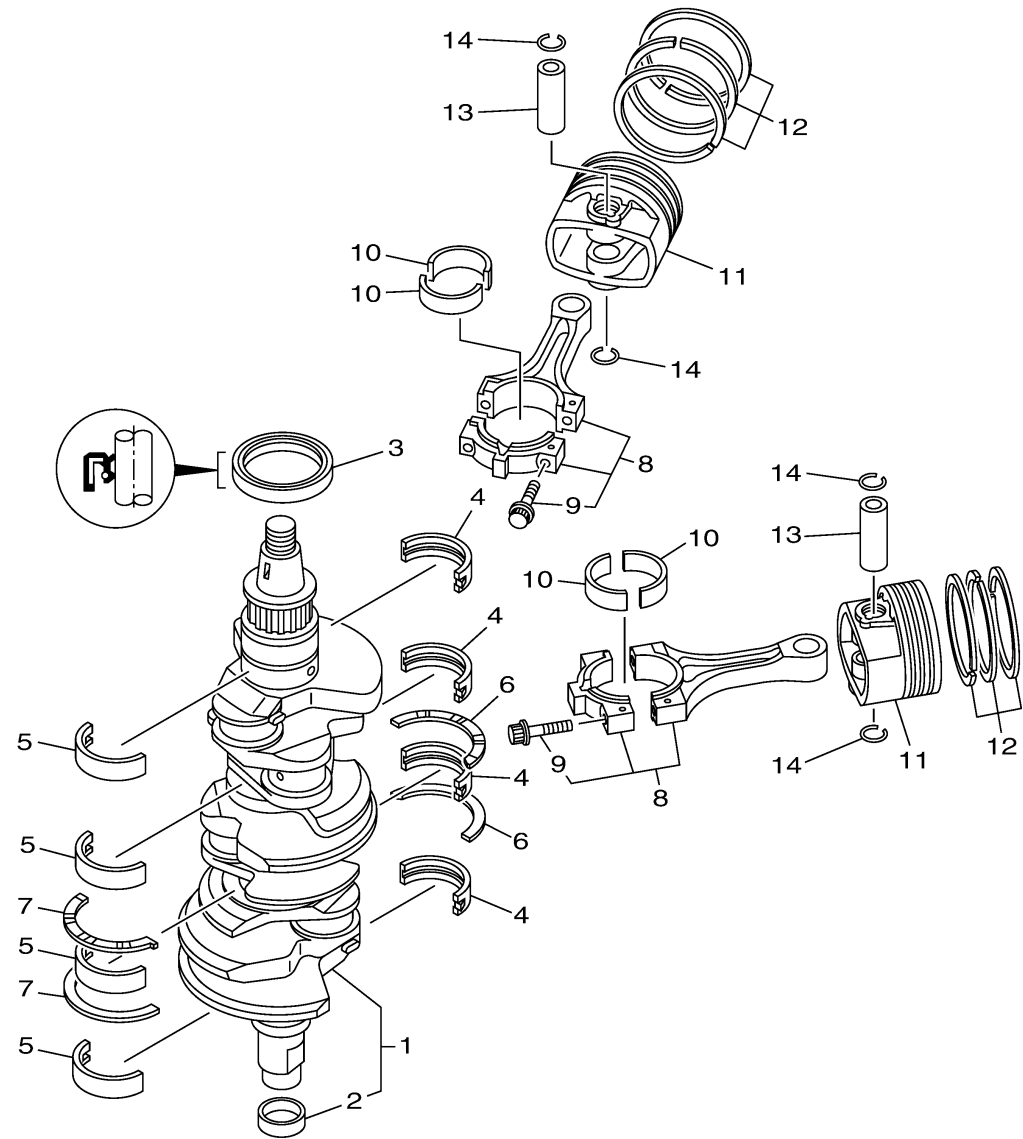

FWD
6ALB100-P040