

CYLINDER CRANKCASE 2

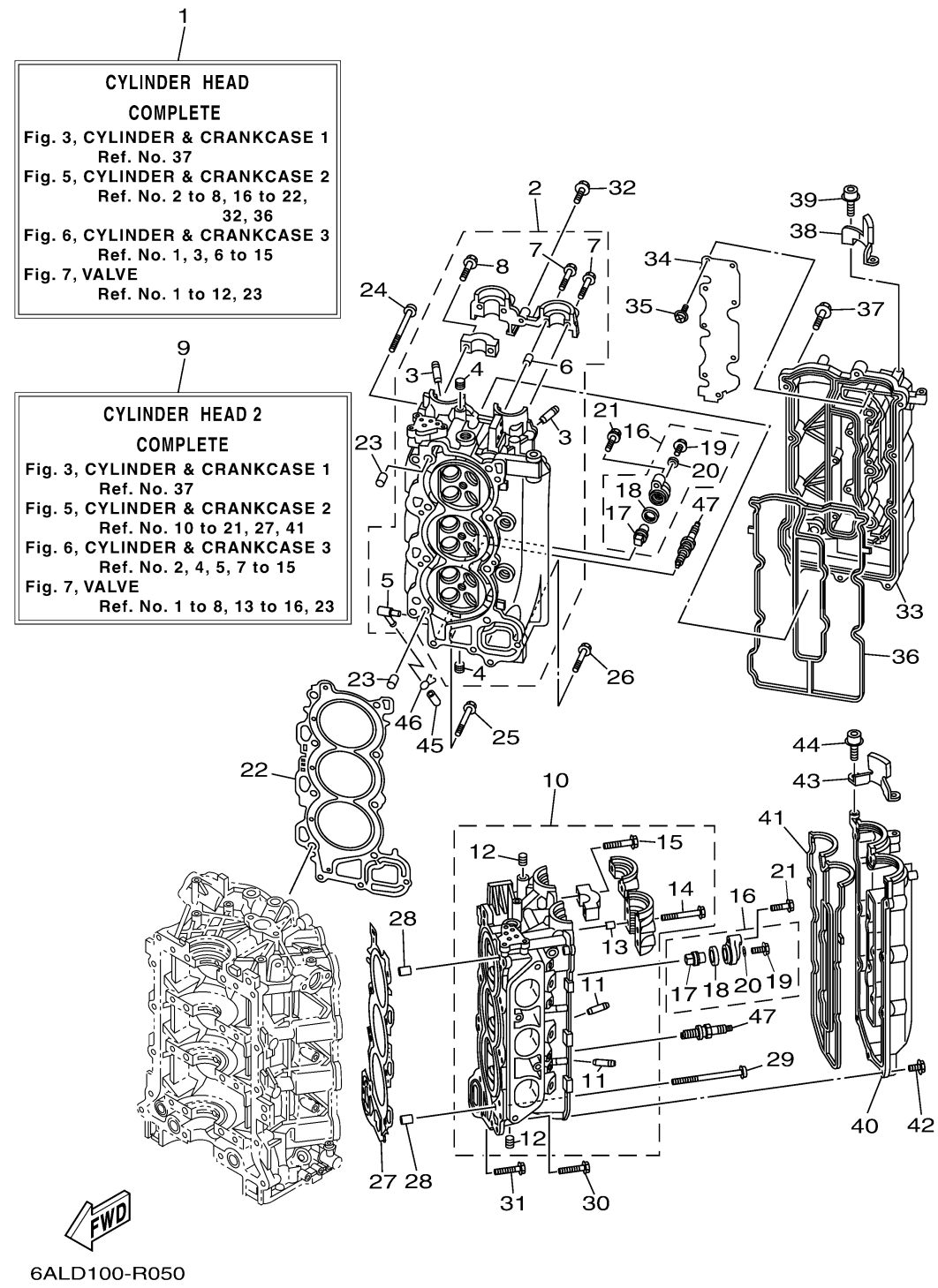

Ref No.	Part Number	Description	Qty	Remarks
1	6P2-W009A-05-9S	CYLINDER HEAD COMPLETE	1	
2	6P2-11110-12-9S	CYLINDER HEAD ASSY	1	
3	6S5-11133-10-00	..GUIDE, VALVE 1	12	
4	90344-51019-00	..PLUG, TAPER SCREW	7	
5	676-11372-00-00	..NIPPLE, HOSE	1	
6	91809-08006-00	..PIN, DOWEL	2	
7	90119-07001-00	..BOLT, WITH WASHER	4	
8	90119-07234-00	..BOLT, WITH WASHER	14	
9	6P2-W009C-05-9S	CYLINDER HEAD 2 COMPLETE	1	
10	6P2-11120-12-9S	CYLINDER HEAD ASSY 2	1	
11	6S5-11133-10-00	..GUIDE, VALVE 1	12	
12	90344-51019-00	..PLUG, TAPER SCREW	3	
13	91809-08006-00	..PIN, DOWEL	4	
14	90119-07235-00	..BOLT/WASHER-CAM CAPS	6	
15	90119-07234-00	..BOLT, WITH WASHER	12	
16	69J-11301-00-00	ANODE COVER ASSY	4	
17	67F-11325-01-00	..ANODE	1	
18	67F-11328-00-00	..GROMMET, ANODE	1	
19	90105-06M07-00	..BOLT, FLANGE	1	
20	90430-06M03-00	..GASKET	1	

CONTINUED ON NEXT FRAME >

CYLINDER CRANKCASE 2

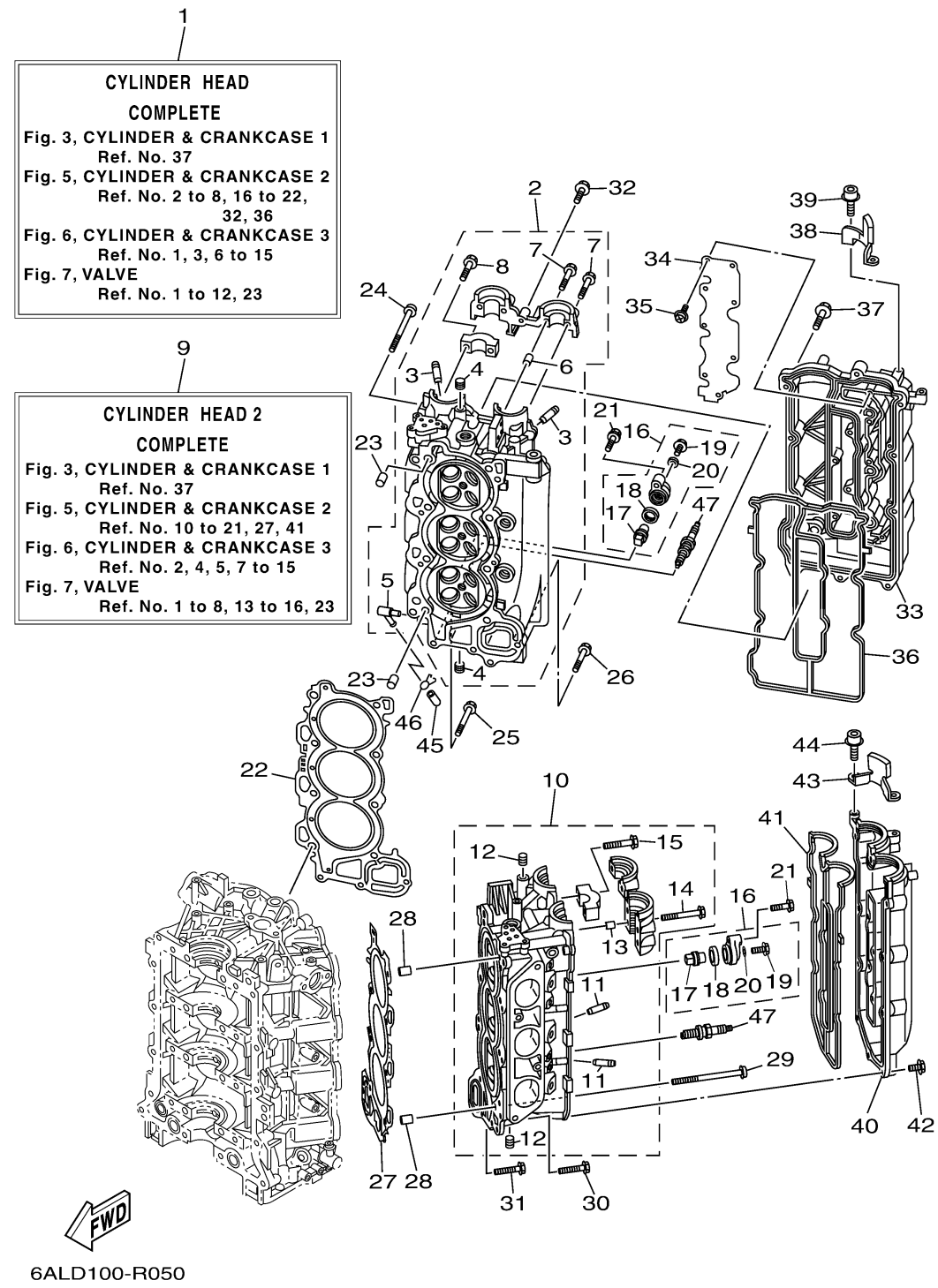

Ref No.	Part Number	Description	Qty	Remarks
21	97E75-08540-00	BOLT, HEXAGON W/W DEEP RECESS	4	
22	6P2-11181-00-00	.GASKET, CYLINDER HEAD 1	1	
23	99530-14016-00	PIN, DOWEL	2	
24	90155-10009-00	SCREW, FLAT FILLISTER	8	
25	90119-08M91-00	BOLT, WITH WASHER	2	
26	90119-08021-00	BOLT, WITH WASHER	1	
27	6P2-11182-00-00	.GASKET, CYLINDER HEAD 2	1	
28	99530-14016-00	PIN, DOWEL	2	
29	90155-10009-00	SCREW, FLAT FILLISTER	8	
30	90119-08M91-00	BOLT, WITH WASHER	2	
31	90119-08021-00	BOLT, WITH WASHER	1	
32	97E95-06530-00	BOLT, HEXAGON W/W DEEP RECESS	1	
33	6P2-11191-00-9S	COVER, CYLINDER HEAD 1	1	
34	6P2-11135-00-00	PLATE, BREATHER 3	1	
35	97607-04208-00	SCREW, WITH WASHER	8	
36	6P2-11193-00-00	.GASKET, HEAD COVER 1	1	
37	97E95-06530-00	BOLT, HEXAGON W/W DEEP RECESS	14	
38	6P2-15142-00-00	GUIDE 1	1	
39	90110-06150-00	BOLT, HEXAGON SOCKET HEAD	2	
40	6P2-11192-00-9S	COVER, CYLINDER HEAD 2	1	

CONTINUED ON NEXT FRAME >

CYLINDER CRANKCASE 2

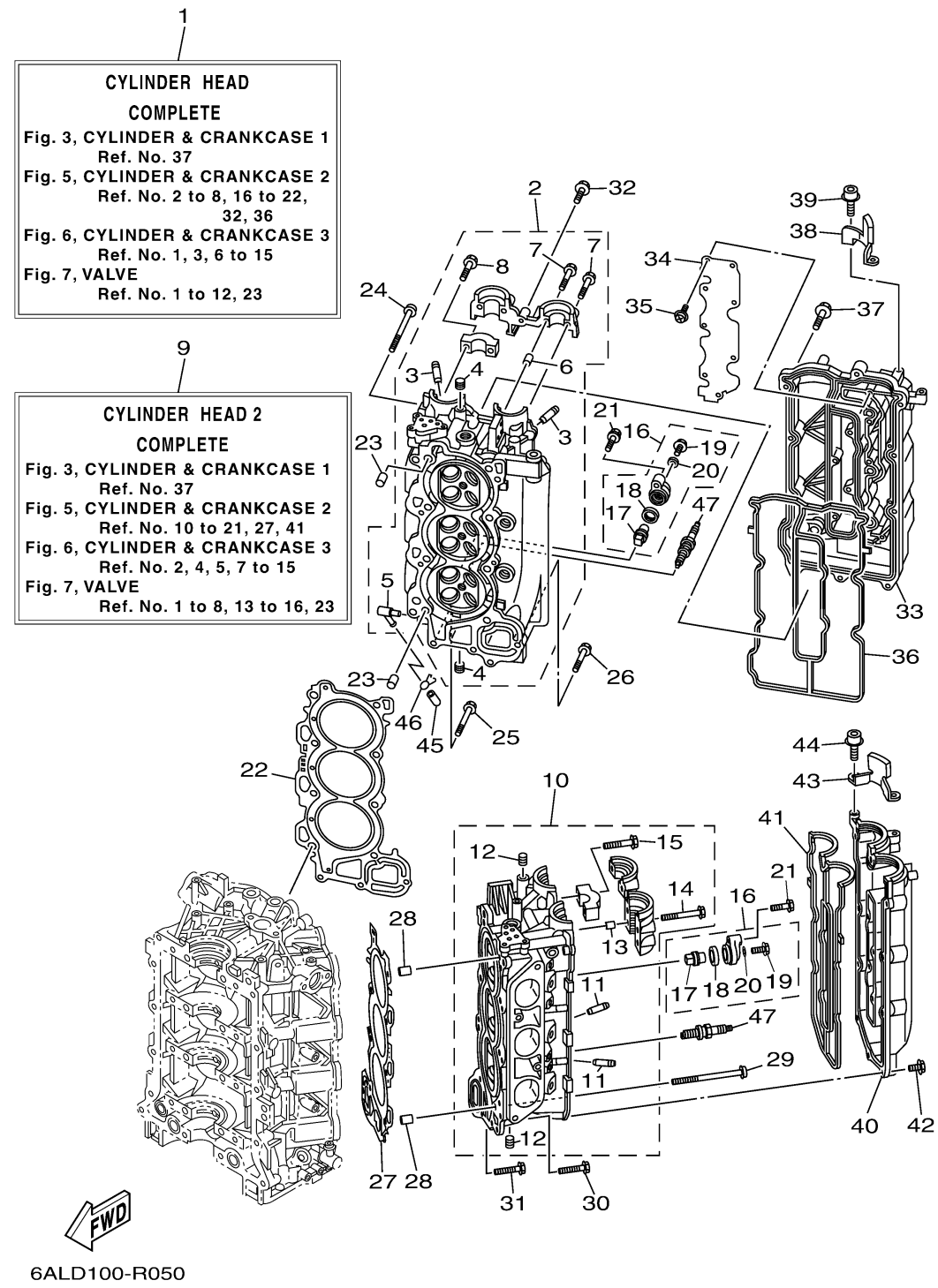

Ref No.	Part Number	Description	Qty	Remarks
41	6P2-11194-00-00	.GASKET, HEAD COVER 2	1	
42	97E95-06530-00	BOLT, HEXAGON W/W DEEP RECESS	14	
43	6P2-15143-00-00	GUIDE	1	
44	90110-06150-00	BOLT, HEXAGON SOCKET HEAD	2	
45	6P2-13448-00-00	CAP	1	
46	90467-08M18-00	CLIP	1	
47	LFR-6A110-00-00	PLUG, SPARK (NGK LFR6A-11)	6	