

# OIL PAN

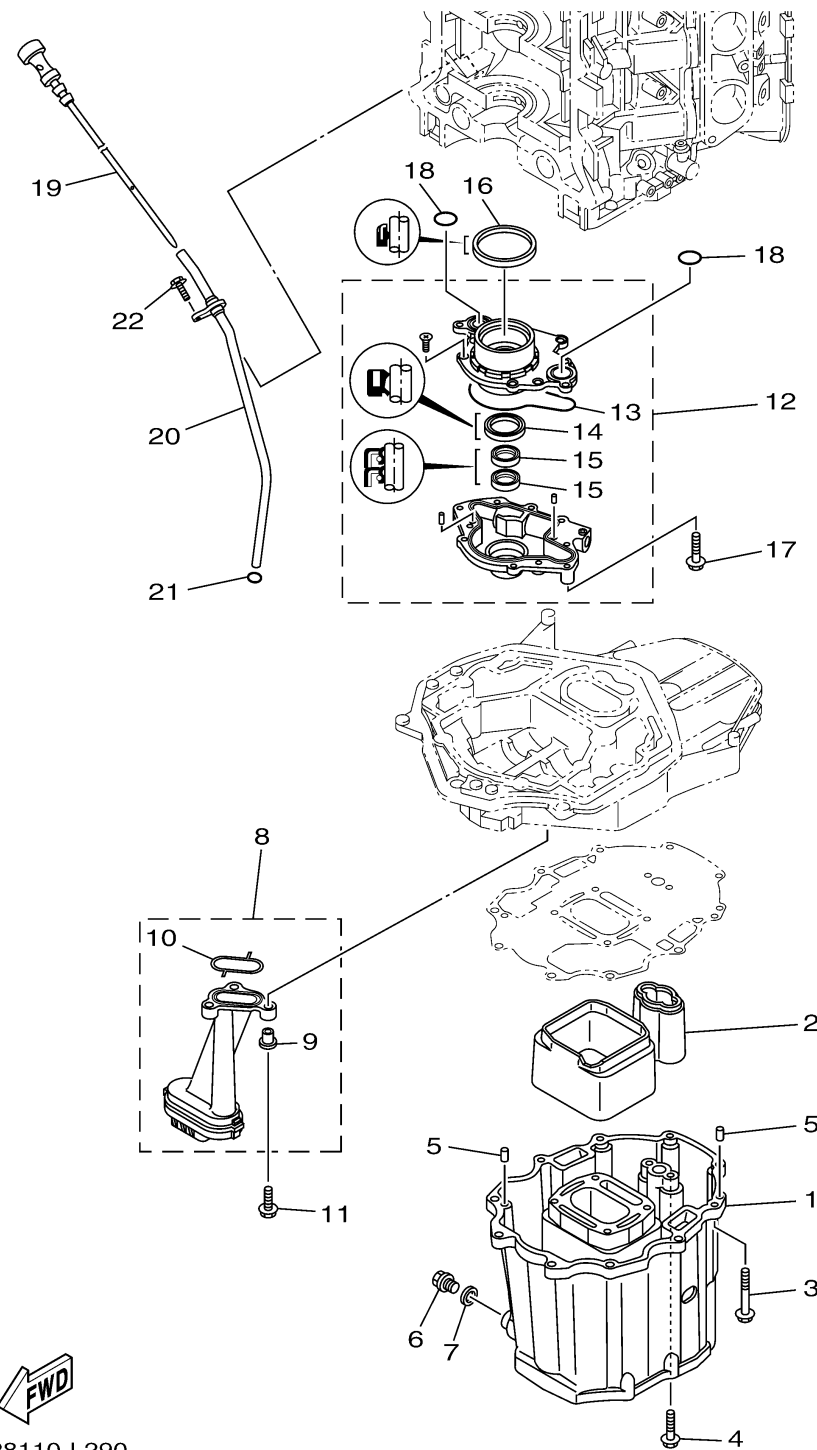

| Ref No. | Part Number     | Description                   | Qty | Remarks |
|---------|-----------------|-------------------------------|-----|---------|
| 1       | 69J-15311-10-CA | OIL PAN                       | 1   |         |
| 2       | 69J-15761-00-00 | SEAL, RUBBER 1                | 1   |         |
| 3       | 97E75-08560-00  | BOLT, HEXAGON W/W DEEP RECESS | 10  |         |
| 4       | 97E75-08535-00  | BOLT, HEXAGON W/W DEEP RECESS | 2   |         |
| 5       | 93608-16M16-00  | PIN, DOWEL                    | 2   |         |
| 6       | 90340-14M06-00  | PLUG, STRAIGHT SCREW          | 1   |         |
| 7       | 90430-14M09-00  | .GASKET                       | 1   |         |
| 8       | 69J-13411-00-00 | STRAINER, OIL                 | 1   |         |
| 9       | 90387-06263-00  | . .COLLAR                     | 3   |         |
| 10      | 69J-13415-00-00 | . .SEAL, OIL STRAINER         | 1   |         |
| 11      | 95812-06025-00  | BOLT, FLANGE                  | 3   |         |
| 12      | 6P2-13300-00-00 | OIL PUMP ASSY                 | 1   |         |
| 13      | 69J-13329-01-00 | . .GASKET, PUMP COVER         | 1   |         |
| 14      | 6AW-13119-00-00 | . .OIL SEAL                   | 1   |         |
| 15      | 69J-13631-00-00 | . .OIL SEAL                   | 2   |         |
| 16      | 69J-11355-00-00 | .SEAL, CYLINDER 1             | 1   |         |
| 17      | 97E75-06540-00  | BOLT, HEXAGON W/W DEEP RECESS | 4   |         |
| 18      | 93210-25552-00  | O-RING                        | 2   |         |
| 19      | 6P2-15362-10-00 | PLUG, OIL LEVEL               | 1   |         |
| 20      | 6P2-15377-10-00 | GUIDE, INLET                  | 1   |         |

CONTINUED ON NEXT FRAME >

# OIL PAN

| Ref No. | Part Number    | Description              | Qty | Remarks |
|---------|----------------|--------------------------|-----|---------|
| 21      | 93210-19MJ3-00 | .O-RING                  | 1   |         |
| 22      | 95D95-06016-00 | BOLT, FLANGE DEEP RECESS | 1   |         |

