

# CYLINDER CRANKCASE 2

Ref No.	Part Number	Description	Qty	Remarks
1	6HY-W009A-00-1S	CYLINDER HEAD COMPLETE	1	
2	6FM-11111-00-1S	HEAD, CYLINDER 1	1	
3	6AH-11133-10-00	.GUIDE, VALVE 1	4	
4	6FM-11181-00-00	.GASKET, CYLINDER HEAD 1	1	
5	99530-08012-00	PIN, DOWEL	2	
6	90105-09010-00	BOLT, FLANGE	6	
7	90119-06MA3-00	BOLT, WITH WASHER	3	
8	6FM-11191-00-00	COVER, CYLINDER HEAD 1	1	
9	6FM-11356-00-00	.SEAL, CYLINDER 2	1	
10	90105-06M07-00	BOLT, FLANGE	5	
11	6FM-11168-00-00	COVER, BREATHER	1	
12	97607-04210-00	SCREW, WITH WASHER	5	
13	6G8-11325-00-00	ANODE	2	
14	98980-05025-00	SCREW, BIND	2	
15	6G8-11197-A0-00	PLUG, BLIND	2	
16	93210-13M63-00	O-RING	2	
17	90465-08059-00	CLAMP	1	
18	6HY-15407-00-00	ELEMENT 1	1	
19	6G8-15363-00-00	PLUG, OIL	1	
20	93210-24M79-00	.O-RING	1	

CONTINUED ON NEXT FRAME >

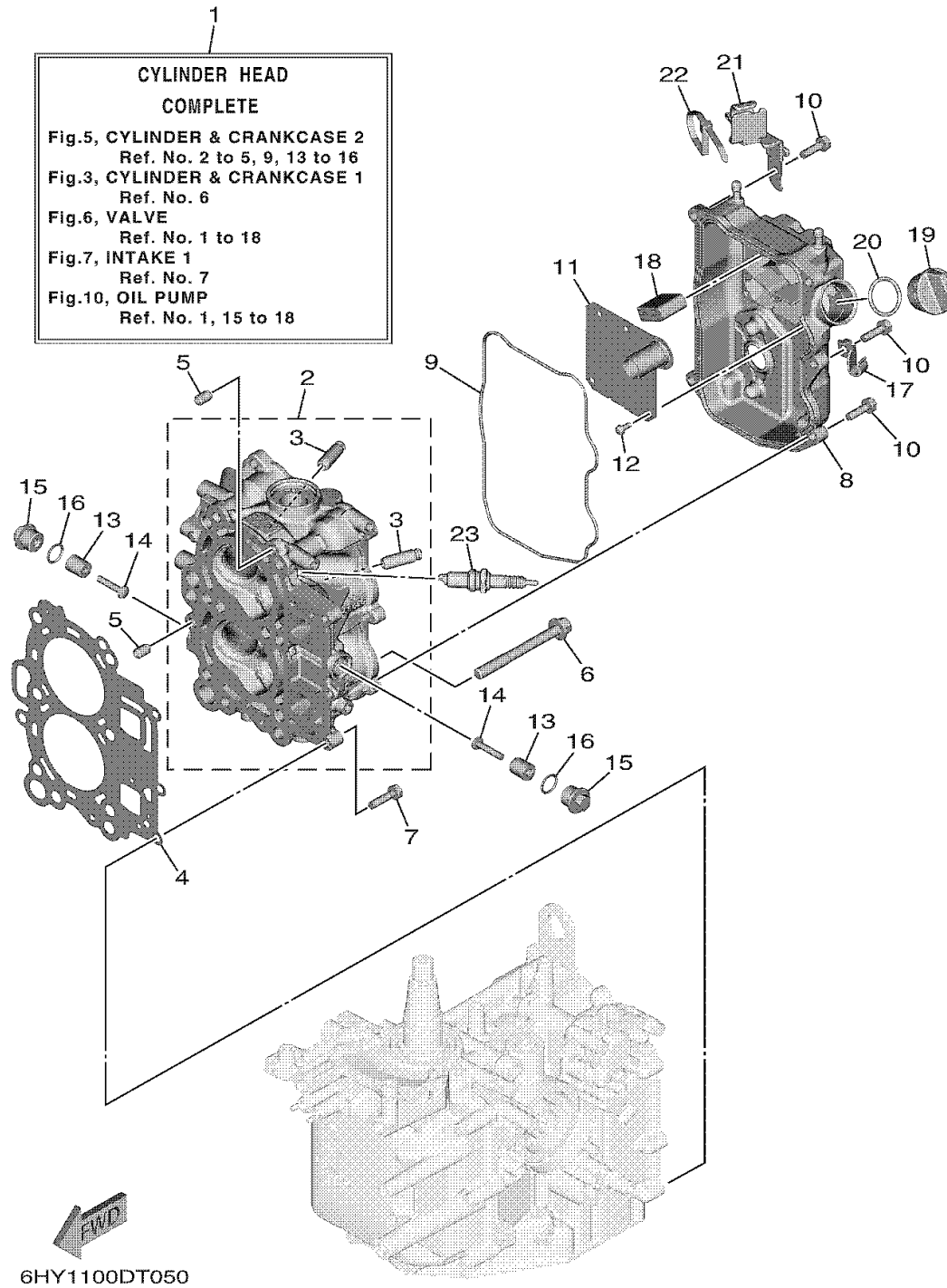

## CYLINDER CRANKCASE 2

Ref No.	Part Number	Description	Qty	Remarks
21	6FM-2475H-00-00	BRACKET, SEAT LEVER 1	1	
22	90465-13M18-00	CLAMP	1	
23	94702-00418-00	PLUG, SPARK (NGK DPR6EB-9)	2	

