

CONTROL

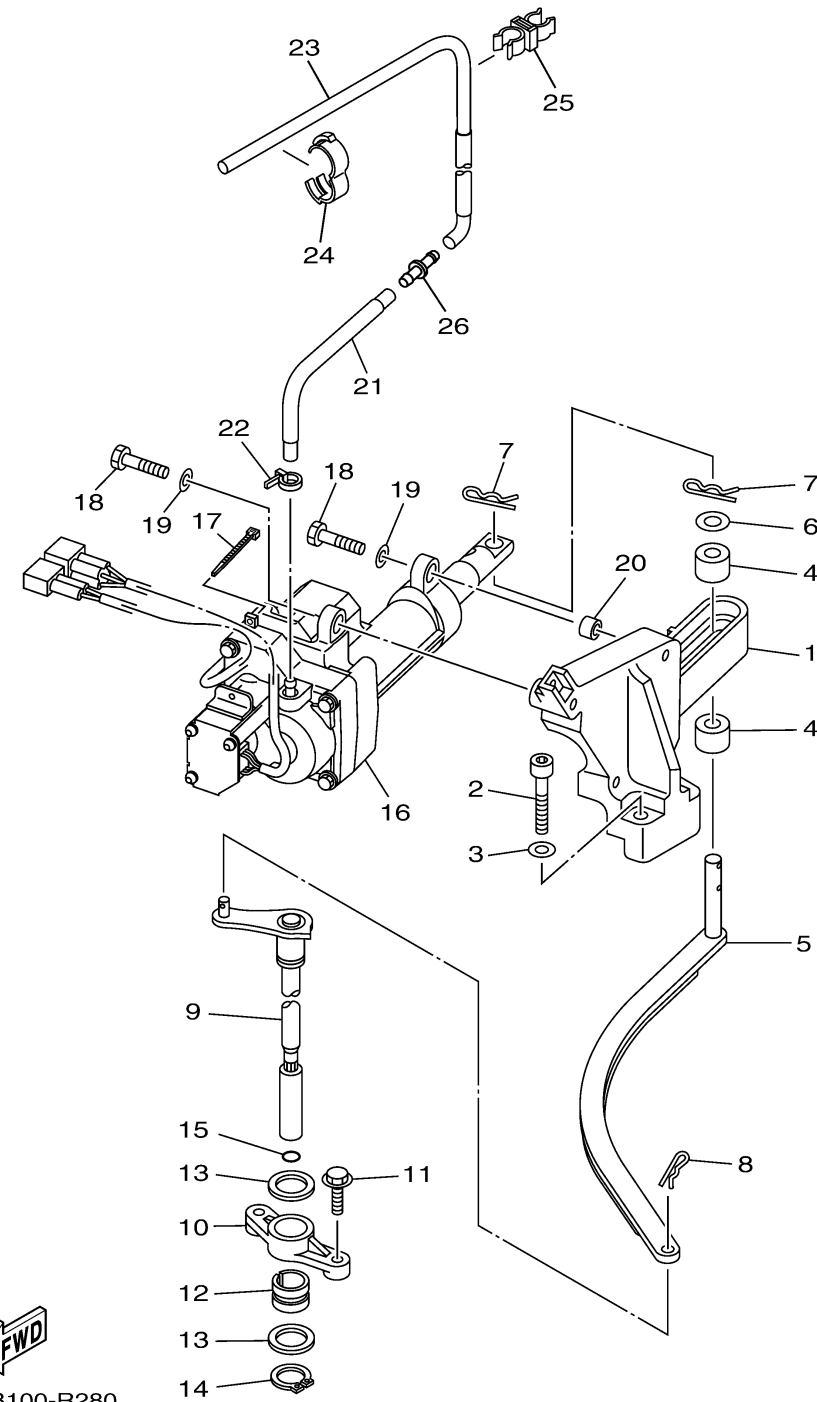

Ref No.	Part Number	Description	Qty	Remarks
1	6AW-44176-00-00	BRACKET	1	
2	90110-08085-00	BOLT, HEXAGON SOCKET HEAD	2	
3	92990-08600-00	WASHER, PLATE	2	
4	6AW-44122-00-00	BUSHING, SHIFT ROD LEVER	2	
5	6AW-44121-00-00	LEVER, SHIFT ROD	1	
6	90201-11008-00	WASHER, PLATE	1	
7	90468-180A0-00	CLIP	2	
8	90468-18008-00	CLIP	1	
9	6AW-44120-01-00	HANDLE GEAR SHIFT ASSY	1	
10	6AW-44118-01-00	BRACKET	1	
11	97E95-06525-00	BOLT, HEXAGON W/W DEEP RECESS	2	
12	90380-19001-00	BUSH, SOLID	1	
13	90202-19001-00	WASHER, PLATE	2	
14	93410-19088-00	CIRCLIP	1	
15	93210-09165-00	O-RING	1	
16	6AW-4820A-11-00	ACTUATOR UNIT	1	
17	90465-11M10-00	CLAMP	1	
18	97080-08030-00	BOLT	4	
19	92900-08600-00	WASHER	4	
20	90387-08M31-00	COLLAR	2	

CONTINUED ON NEXT FRAME >

CONTROL

Ref No.	Part Number	Description	Qty	Remarks
21	6AW-24314-10-00	PIPE 4	1	
22	90465-11M10-00	CLAMP	1	
23	6AW-24314-00-00	PIPE 4	1	
24	90464-16001-00	CLAMP	1	
25	90464-10M59-00	CLAMP	1	
26	6G8-24376-00-00	PIPE, JOINT 1	1	

