

POWER TRIM TILT ASSY 1

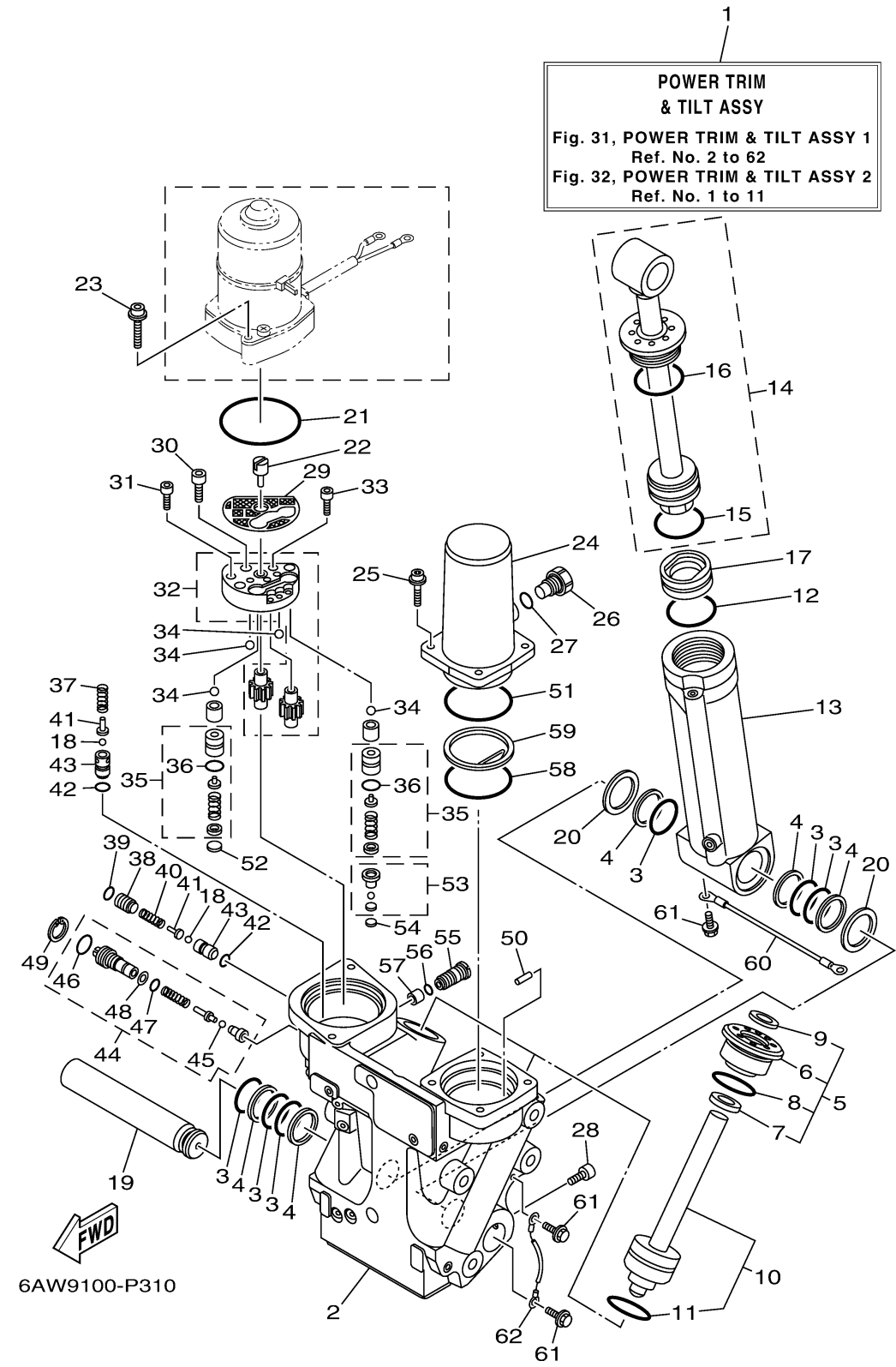

Ref No.	Part Number	Description	Qty	Remarks
1	6AW-43800-05-00	POWER TRIM & TILT ASSY	1	
2	6AW-43825-03-00	HOUSING, TRIM & TILT	1	
3	6AW-4389H-00-00	O-RING	6	
4	6AW-43871-00-00	RING, BACK UP	5	
5	6AW-4380R-01-00	CYLINDER END SUB ASSY	2	
6	6AW-43821-01-00	. .SCREW, TRIM CYLINDER END	1	
7	6AW-4384J-00-00	. .SEAL, TRIM DOWN	1	
8	6E5-43862-00-00	. .O-RING	1	
9	6AW-43822-00-00	. .SEAL, TRIM DUST	1	
10	6AW-43820-01-00	TRIM PISTON SUB ASSY	2	
11	6G5-43864-00-00	. .O-RING	1	
12	6E5-43862-00-00	.O-RING	1	
13	6AW-43813-00-00	CYLINDER, TILT	1	
14	6AW-43810-01-00	TILT PISTON SUB ASSY	1	
15	6E5-43862-00-00	. .O-RING	1	
16	64E-43866-00-00	. .O-RING	1	
17	6AW-43814-00-00	PISTON, FREE	1	
18	64E-43858-00-00	.BALL	2	
19	6AW-4381A-01-00	SHAFT	1	
20	6AW-4387G-00-00	WASHER	2	

CONTINUED ON NEXT FRAME >

POWER TRIM TILT ASSY 1

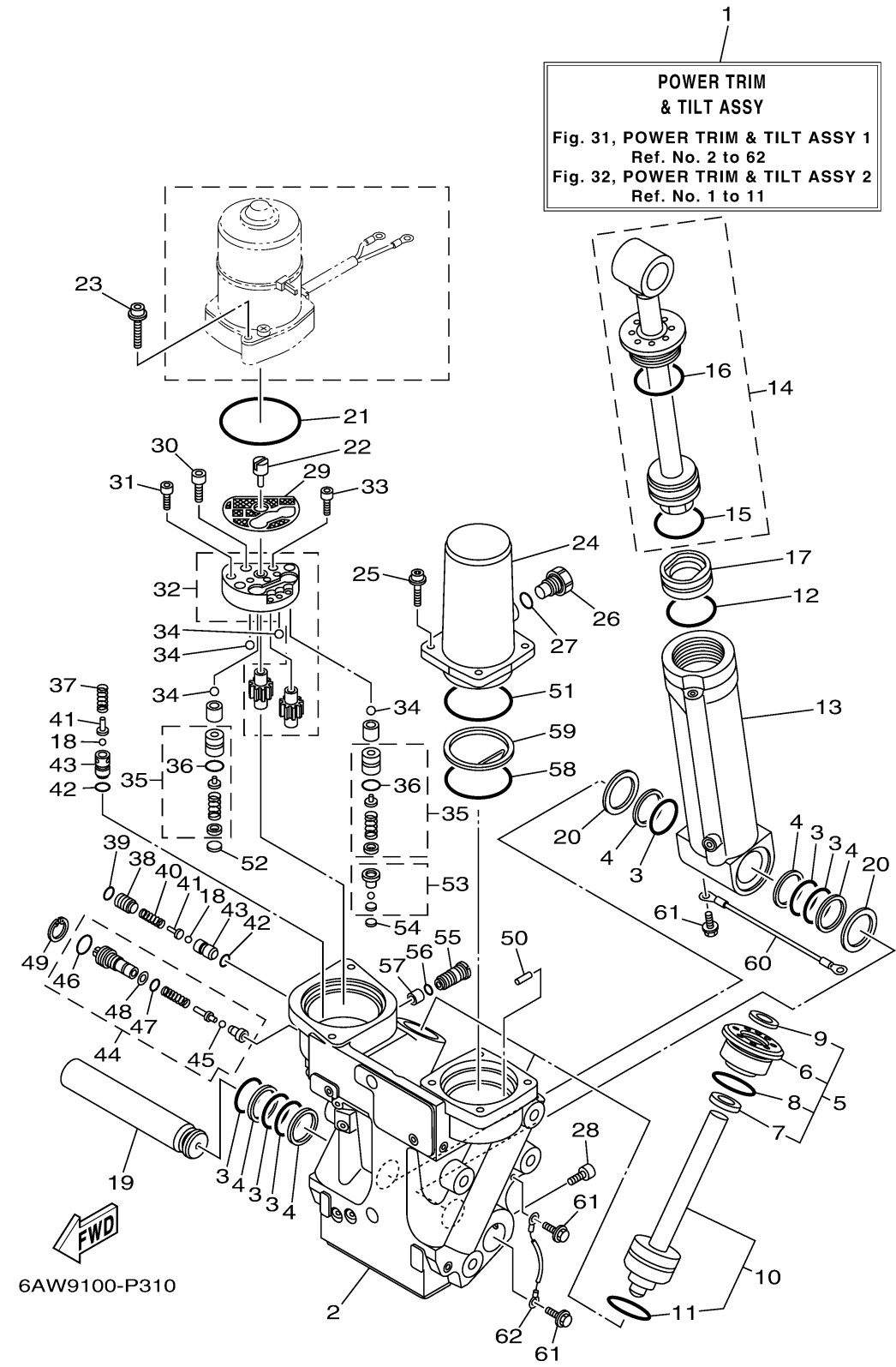

Ref No.	Part Number	Description	Qty	Remarks
21	64E-43868-00-00	O-RING	1	
22	64E-43831-00-00	CONNECTOR, SHAFT	1	
23	6AW-43879-00-00	SCREW, WITH WASHER	2	
24	6AW-43828-00-00	BODY, RESERVOIR	1	
25	6AW-43887-00-00	BOLT	4	
26	6AW-43829-00-00	PLUG, RESERVOIR	1	
27	6AW-43897-00-00	O-RING	1	
28	6AW-4388E-00-00	BOLT ,SCREW	1	
29	64E-43817-11-00	FILTER 2	1	
30	6AW-43878-00-00	BOLT, SOCKET	4	
31	6AW-43888-00-00	BOLT, SOCKET	3	
32	6AW-43830-00-00	GEAR PUMP ASSY	1	
33	6AW-43886-00-00	BOLT	1	
34	6AW-43858-00-00	BALL	4	
35	6AW-43802-00-00	VALVE SUB ASSY	2	
36	6E5-43896-00-00	. .O-RING	1	
37	6AW-43856-00-00	SPRING, DOWN RELIEF	1	
38	6AW-4388J-00-00	PLUG 2	1	
39	6AW-43869-00-00	O-RING	1	
40	6AW-4384H-00-00	SPRING	1	

CONTINUED ON NEXT FRAME >

POWER TRIM TILT ASSY 1

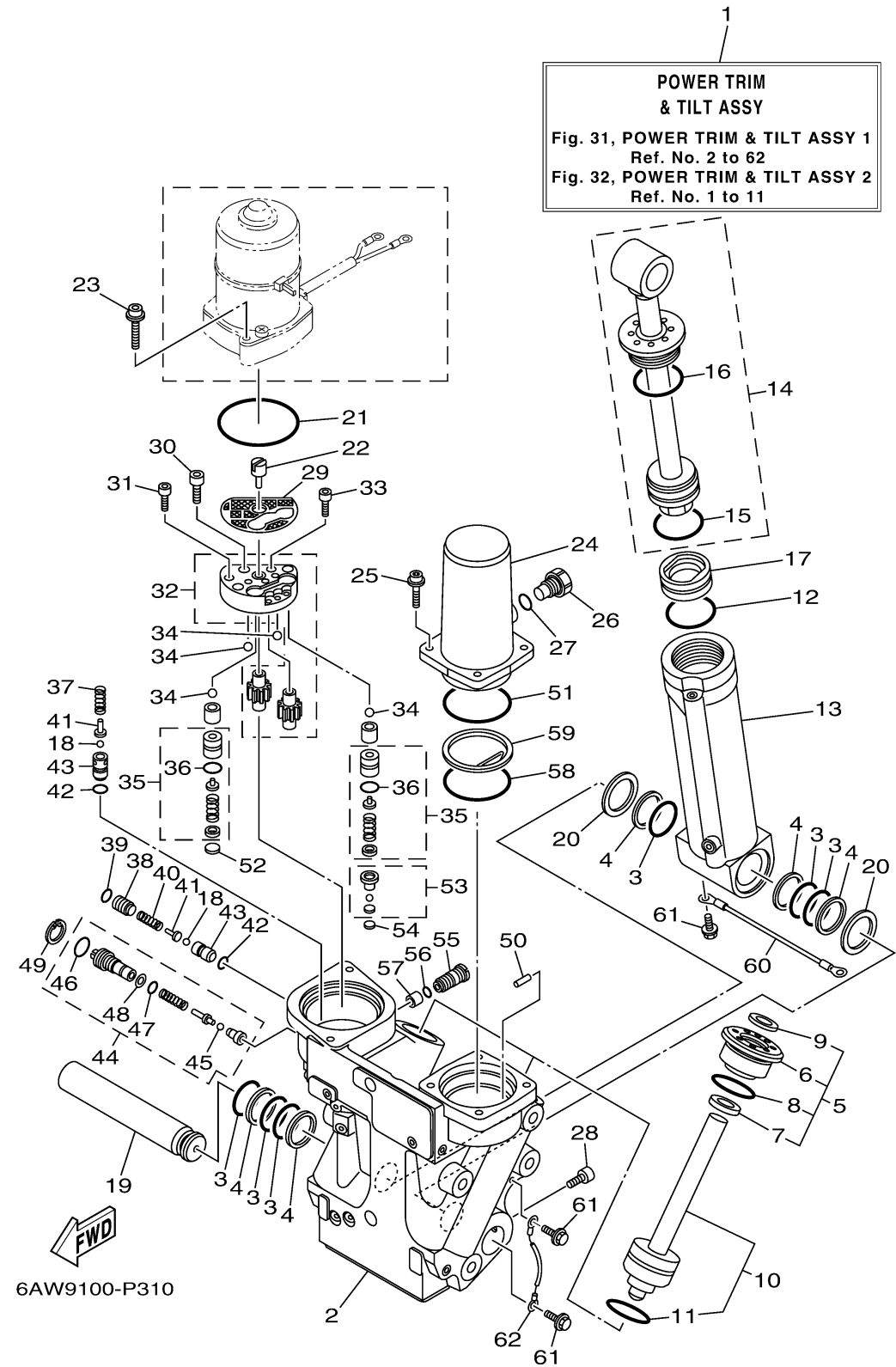

Ref No.	Part Number	Description	Qty	Remarks
41	6AW-43844-00-00	PIN, VALVE SUPPORT	2	
42	6G5-43863-00-00	O-RING	2	
43	6AW-4382G-00-00	VALVE SEAT	2	
44	6AW-43860-01-00	MANUAL VALVE SUB-ASSY	1	
45	64E-43858-00-00	. .BALL	1	
46	72X-85075-L0-00	. .O-RING	1	
47	64E-4387A-00-00	. .O-RING	1	
48	64E-43873-00-00	. .RING, BACK UP	1	
49	6AW-43875-00-00	RING, SNAP	1	
50	6AW-4381G-00-00	PIN 1	1	
51	6AW-43861-00-00	O-RING	1	
52	6AW-43817-00-00	FILTER 2	1	
53	6AW-43809-00-00	SEAT VALVE COMP. 2	1	
54	64E-43816-00-00	FILTER 1	1	
55	6AX-4388J-00-00	PLUG 2	1	
56	64E-43865-00-00	O-RING	1	
57	6AW-4388H-00-00	PLUG	1	
58	6AW-4389J-00-00	O-RING	1	
59	6AW-43899-00-00	PLATE STOPPER	1	
60	6H1-82148-00-00	WIRE, LEAD 4	1	

CONTINUED ON NEXT FRAME >

POWER TRIM TILT ASSY 1

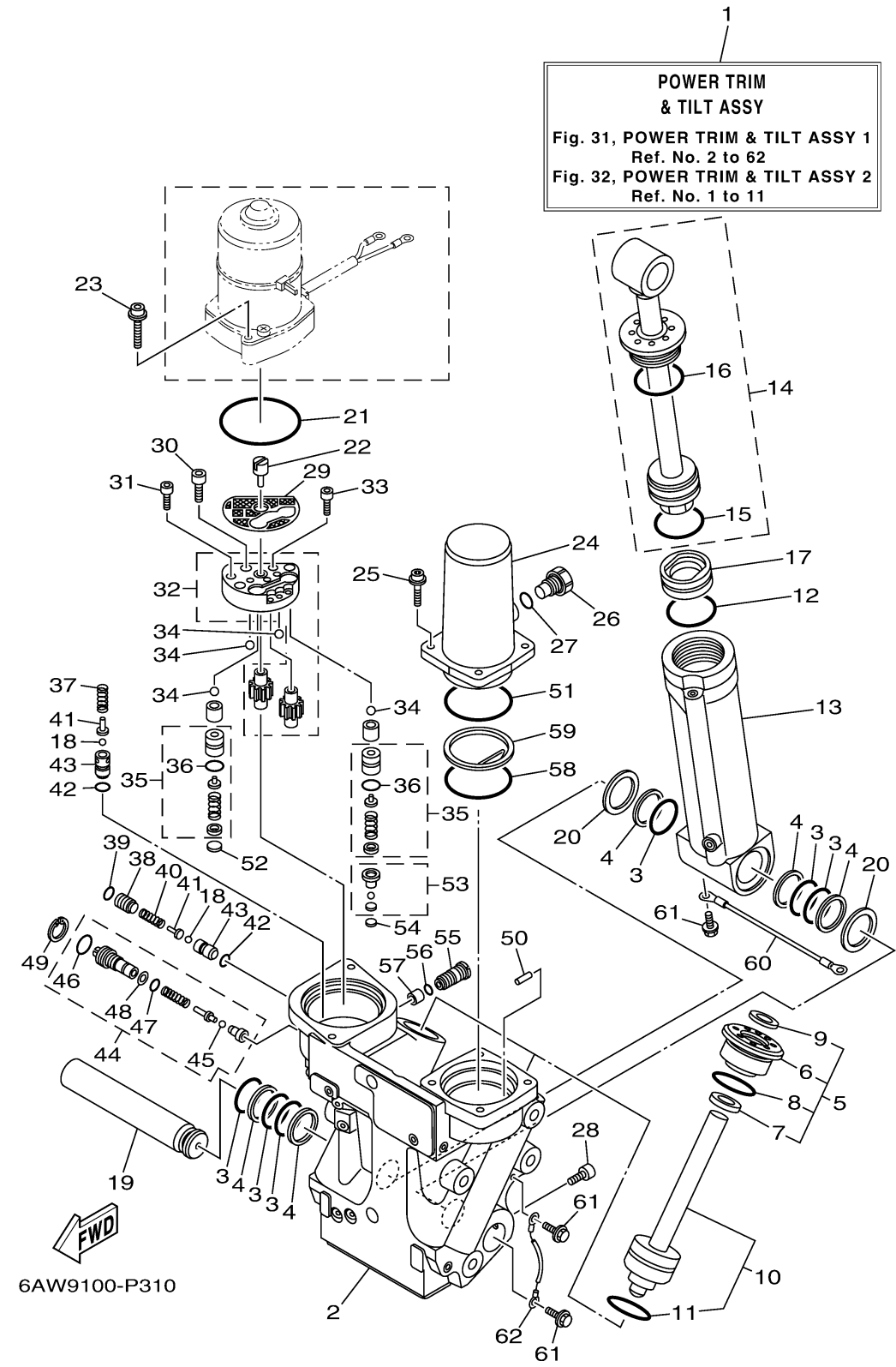

Ref No.	Part Number	Description	Qty	Remarks
61	97595-06510-00	BOLT, WITH WASHER	3	
62	6AW-82148-00-00	WIRE, LEAD 4	1	