

BRACKET 1

Ref No.	Part Number	Description	Qty	Remarks
1	6KA-43111-00-8D	BRACKET, CLAMP 1	1	GRAY
1	6KA-43111-00-CE	BRACKET, CLAMP 1	0	WHITE
2	6G5-45251-02-00	ANODE	1	
3	6G5-44526-00-00	PLATE	2	
4	97E95-06525-00	BOLT, HEXAGON W/W DEEP RECESS	4	
5	6U0-82127-00-00	WIRE, LEAD 2	1	
6	97E95-06510-00	BOLT, HEXAGON W/W DEEP RECESS	1	
7	93700-06002-00	NIPPLE, GREASE	1	
8	6KA-43112-00-8D	BRACKET, CLAMP 2	1	GRAY
8	6KA-43112-00-CE	BRACKET, CLAMP 2	0	WHITE
9	93700-06002-00	NIPPLE, GREASE	1	
10	6KA-43311-00-8D	BRACKET, SWIVEL 1	1	GRAY
10	6KA-43311-00-CE	BRACKET, SWIVEL 1	0	WHITE
11	93700-06002-00	NIPPLE, GREASE	3	
12	97E95-06510-00	BOLT, HEXAGON W/W DEEP RECESS	2	
13	6KA-82147-00-00	WIRE, LEAD 5	1	
14	6G5-43144-00-00	HOOK, SPRING	1	
15	97E95-06512-00	BOLT, HEXAGON W/W DEEP RECESS	1	
16	6KA-43181-00-00	LEVER, TILT STOP 1	1	
17	6KA-43185-00-00	LEVER, TILT STOP 2	1	

CONTINUED ON NEXT FRAME >

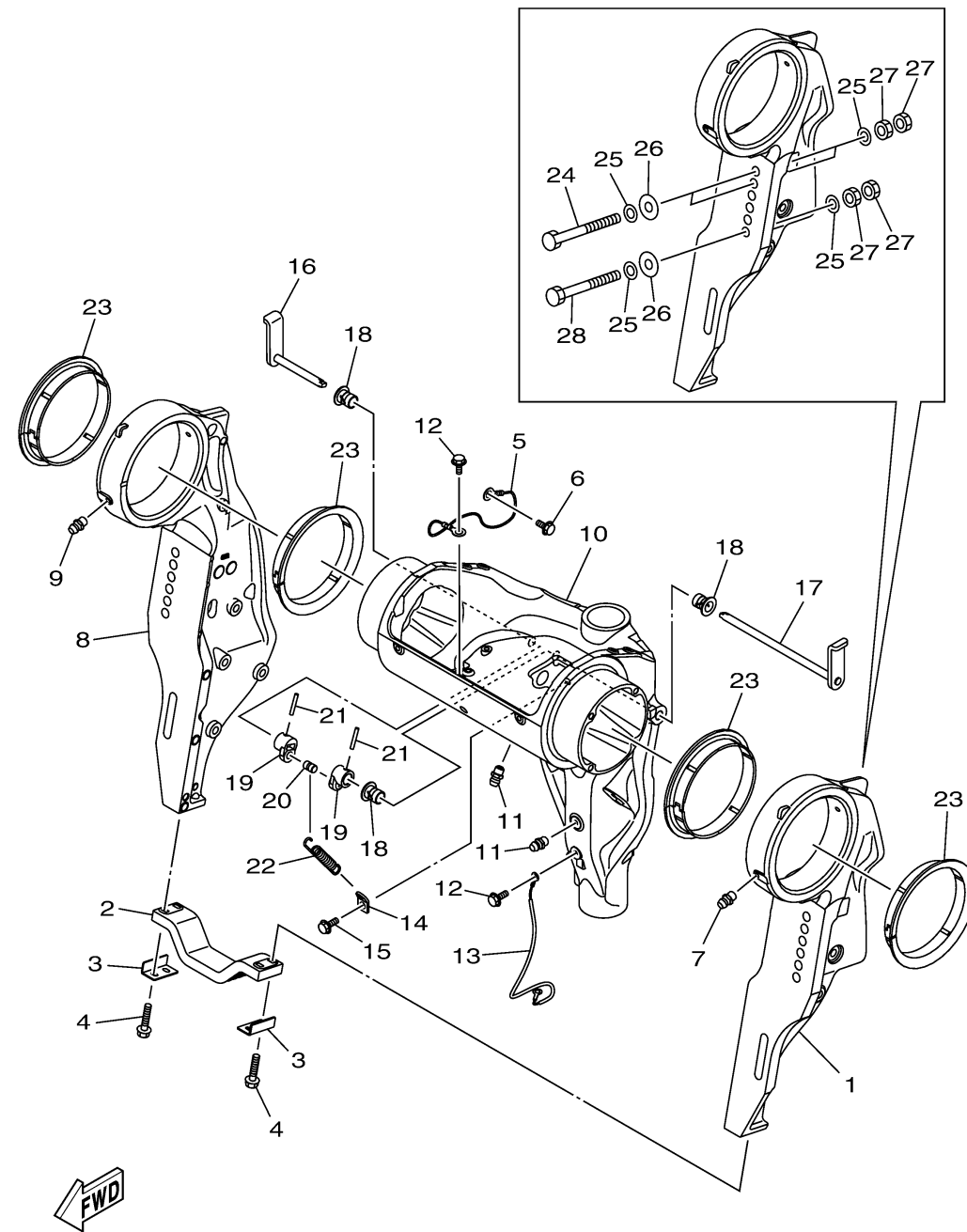

6KA1100-V310

BRACKET 1

Ref No.	Part Number	Description	Qty	Remarks
18	90386-10M16-00	BUSH	3	
19	6G5-43148-00-00	COLLAR, DISTANCE	2	
20	90249-06M19-00	PIN	1	
21	91690-30020-00	PIN, SPRING	2	
22	90506-16010-00	SPRING, TENSION	1	
23	6GR-43333-00-00	BUSH. , SWIVEL BRACKET	4	
24	90101-12067-00	BOLT (150MM)	4	
25	90201-13M01-00	WASHER, PLATE	12	
26	90201-12426-00	WASHER, PLATE	6	
27	95380-12600-00	NUT	12	
28	90101-12076-00	BOLT (130MM)	2	