

SWITCH & PANEL 2 (EKS, TWIN)

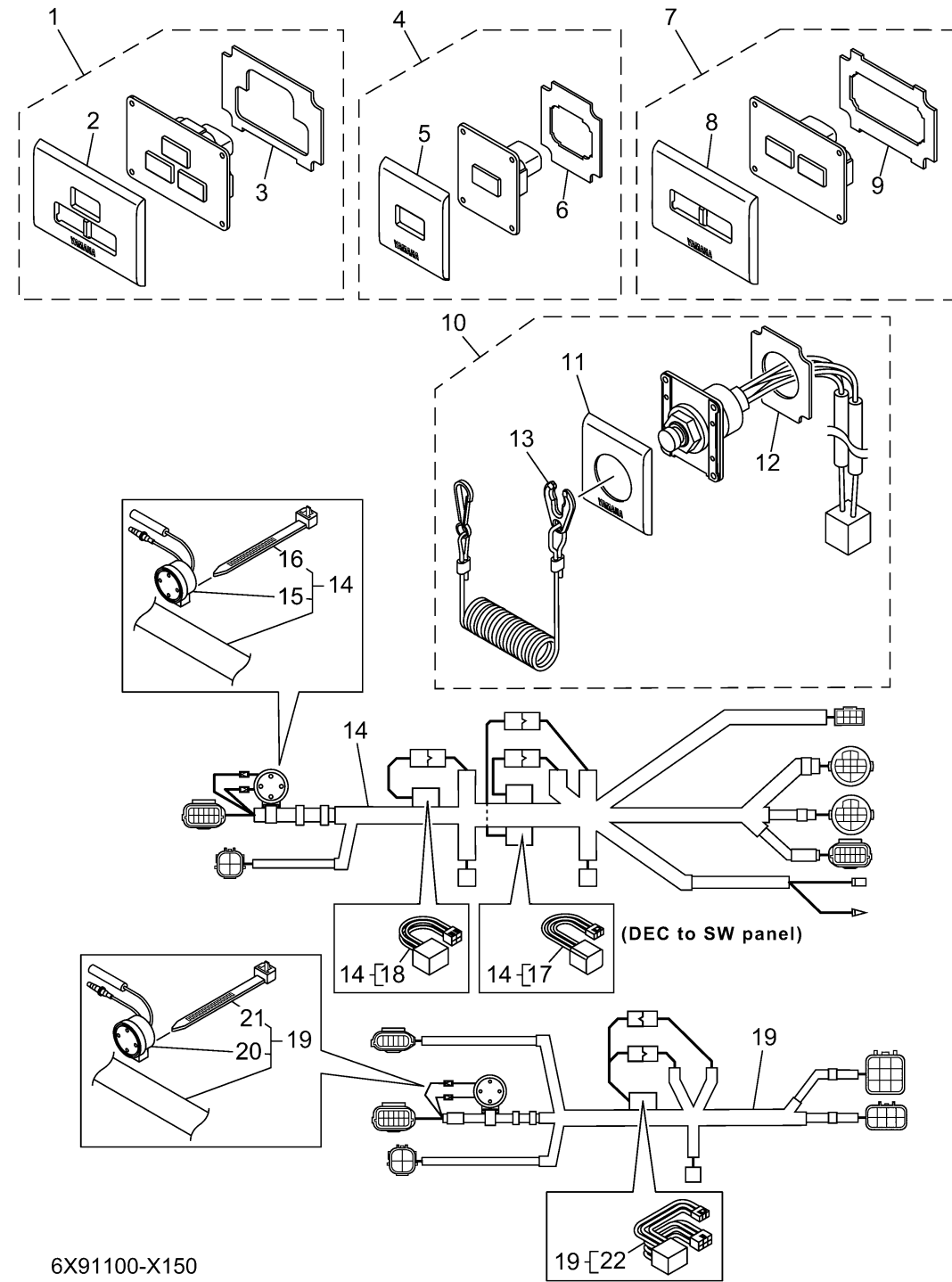

Ref No.	Part Number	Description	Qty	Remarks
1	6X9-82570-11-00	PANEL SWITCH ASSY	1	MAIN STATION
2	6X9-82571-10-00	..PANEL, SWITCH	1	
3	6X9-22480-10-00	..SEAL ASSY	1	
4	6X9-82570-B1-00	PANEL SWITCH ASSY	1	2ND STATION
5	6X9-82571-20-00	..PANEL, SWITCH	1	
6	6X9-22480-20-00	..SEAL ASSY	1	
7	6X9-82570-31-00	PANEL SWITCH ASSY	1	2ND STATION
8	6X9-82571-30-00	..PANEL, SWITCH	1	
9	6X9-22480-30-00	..SEAL ASSY	1	
10	6X9-82570-80-00	PANEL SWITCH ASSY	1	MAIN STATION & 2ND STATION
11	6X9-82571-70-00	..PANEL, SWITCH	1	
12	6X9-22480-70-00	..SEAL ASSY	1	
13	682-82556-00-00	...LANYARD, STOP SWITCH	1	
14	6X9-82716-32-00	EKS HARNESS	1	MAIN STATION
15	703-83383-11-00	..BUZZER	1	
16	90465-13M39-00	..CLAMP	1	
17	6X9-81950-00-00	..RELAY ASSY	2	
18	6X6-81980-00-00	..DIODE ASSY	1	
19	6X9-82716-71-00	EKS HARNESS	1	2ND STATION
20	703-83383-11-00	..BUZZER	1	

CONTINUED ON NEXT FRAME >

SWITCH & PANEL 2 (EKS, TWIN)

Ref No.	Part Number	Description	Qty	Remarks
21	90465-13M39-00	. CLAMP	1	
22	6X6-81980-10-00	..DIODE ASSY	1	

