

CYLINDER CRANKCASE 1

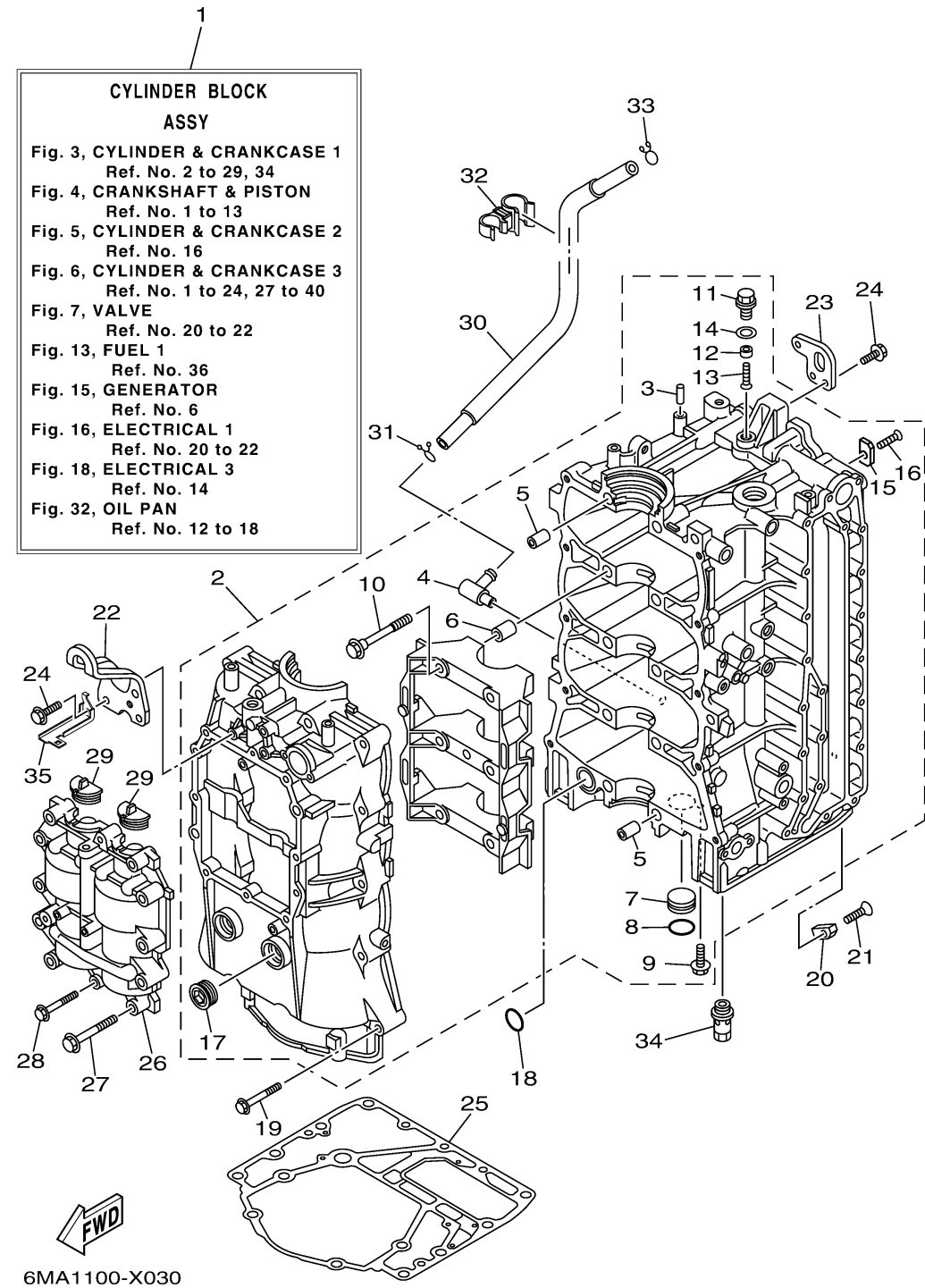

Ref No.	Part Number	Description	Qty	Remarks
1	63P-W009B-14-9S	CYLINDER BLOCK ASSY	1	
2	63P-W1510-04-9S	CRANKCASE ASSY	1	
3	93606-12019-00	. PIN, DOWEL	1	
4	63P-11372-00-00	. NIPPLE, HOSE	1	
5	91814-18002-00	. PIN, DOWEL	4	
6	91814-18002-00	. PIN, DOWEL	6	
7	90338-25004-00	. PLUG	1	
8	93210-25647-00	. O-RING	1	
9	90119-06276-00	. BOLT, WITH WASHER	1	
10	90105-10071-00	. BOLT, FLANGE	10	
11	63P-11197-00-00	. PLUG, BLIND	1	
12	63P-11325-21-00	. ANODE	1	
13	98780-05016-00	. SCREW, FLAT HEAD	1	
14	90430-14115-00	. GASKET	1	
15	63P-11325-11-00	. ANODE	4	
16	90151-06M02-00	. SCREW, COUNTERSUNK	4	
17	90340-27129-00	. PLUG, STRAIGHT SCREW	2	
18	93210-25552-00	...O-RING	1	
19	90119-08M66-00	BOLT, WITH WASHER	10	
20	63P-11325-01-00	ANODE	1	

CONTINUED ON NEXT FRAME >

CYLINDER CRANKCASE 1

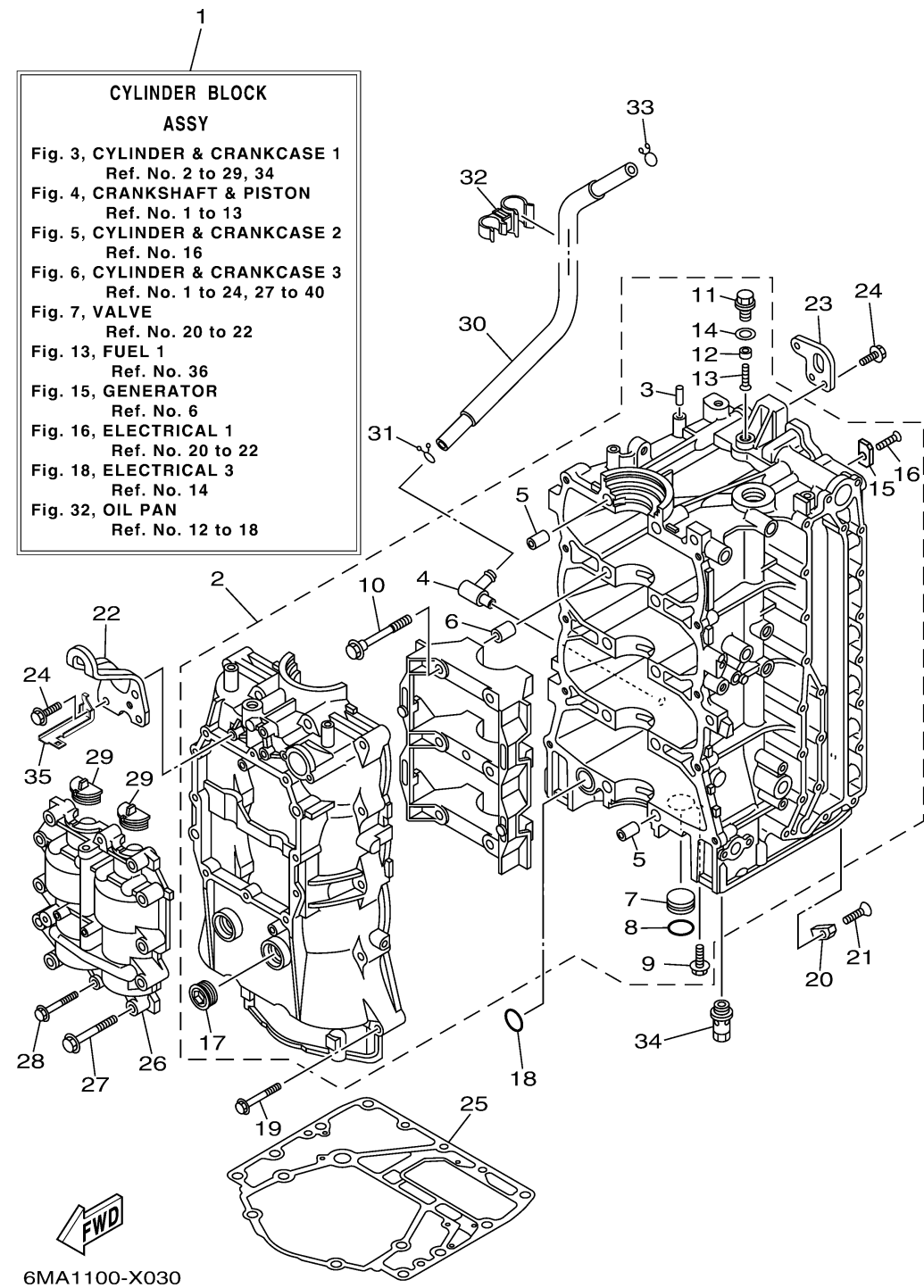

Ref No.	Part Number	Description	Qty	Remarks
21	90151-06M02-00	SCREW, COUNTERSUNK	1	
22	63P-11119-00-00	HANGER, ENGINE	1	
23	63P-11119-10-00	HANGER, ENGINE	1	
24	90119-06MA2-00	BOLT, WITH WASHER	5	
25	63P-11351-03-00	.GASKET, CYLINDER	1	
26	63P-11500-04-00	BALANCER ASSY	1	
27	90119-08M66-00	BOLT, WITH WASHER	10	
28	90119-06MA6-00	BOLT, WITH WASHER	2	
29	63P-11512-00-00	SEAL, CRANK COVER	2	
30	63P-11377-10-00	HOSE	1	
31	90467-15M14-00	CLIP	1	
32	90464-15007-00	CLAMP	1	
33	90467-15M14-00	CLIP	1	
34	63P-13490-00-00	RELIEF VALVE ASSY	1	
35	63P-82588-00-00	PLATE	1	