

LOWER CASING DRIVE 2

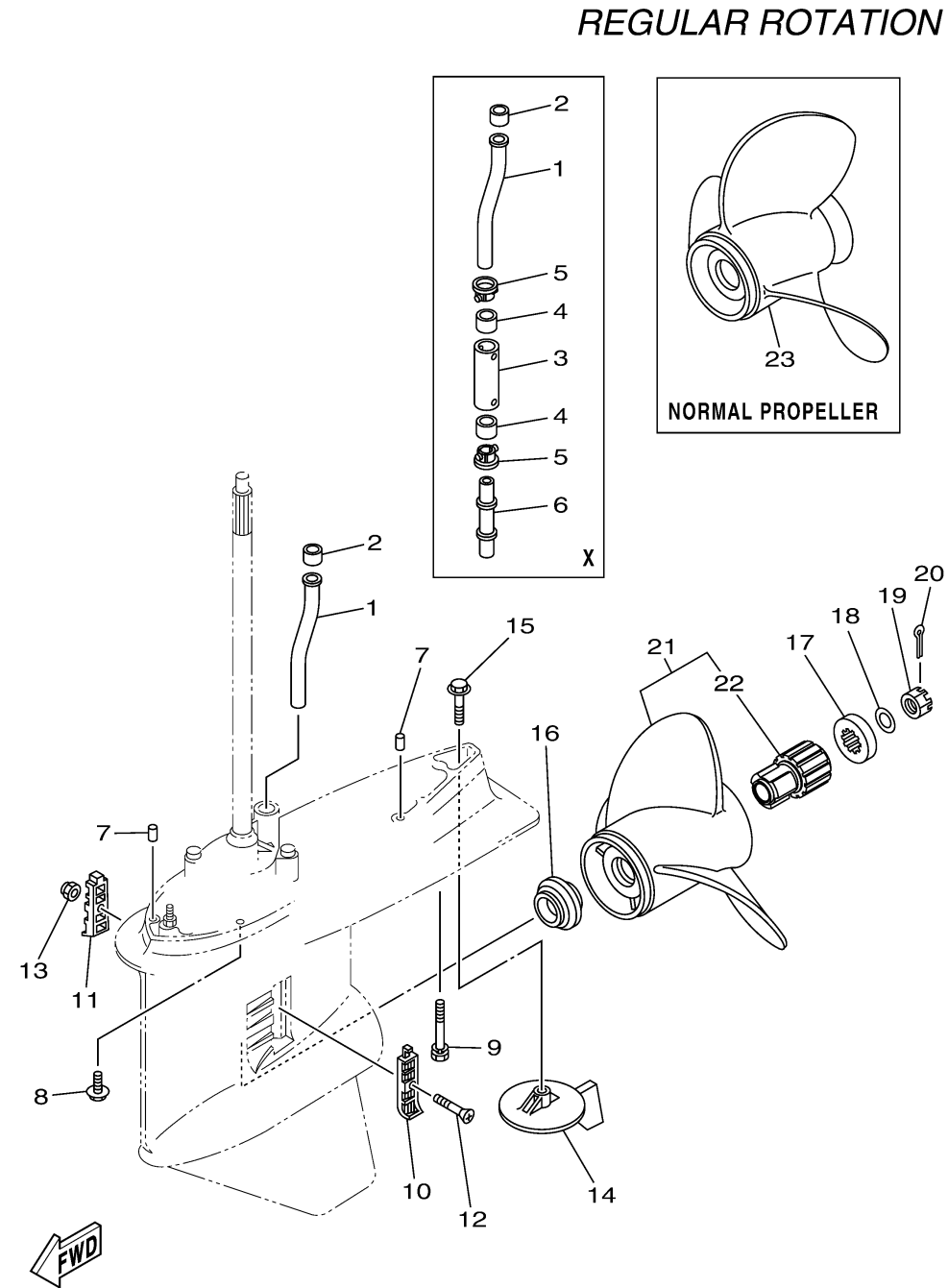

6MA1100-X340

*: FROM REF.NO.3 TO REF.NO.23
EXCEPT FOR JET DRIVE(F150JC)

Ref No.	Part Number	Description	Qty	Remarks
1	63P-44361-00-00	TUBE, WATER 1	1	
2	6E5-44365-01-00	DAMPER, WATER SEAL 1	1	
3	63P-44362-00-00	TUBE, WATER 2	0	X(25.2")
4	6E5-44365-01-00	DAMPER, WATER SEAL 1	0	X(25.2")
5	6E5-44312-00-00	COVER, WATER PUMP HOUSING	0	X(25.2")
6	63P-44363-00-00	TUBE, WATER 3	0	X(25.2")
7	93608-16M16-00	PIN, DOWEL	2	
8	97E95-10645-00	BOLT, HEXAGON W/W DEEP RECESS	6	
9	90119-10008-00	BOLT, WITH WASHER	0	X(25.2")
9	90119-10072-00	BOLT, WITH WASHER	1	L(20.3")
10	6J9-45214-00-00	COVER, WATER INLET 1	1	
11	6J9-45215-00-00	COVER, WATER INLET 2	1	
12	90152-05M08-00	SCREW, COUNTERSUNK	1	
13	90185-05002-00	.NUT, NYLON	1	
14	6J9-45371-01-00	TAB-TRIM	1	
15	90105-10M00-00	BOLT, FLANGE	1	
16	63P-45987-00-00	SPACER 1	1	
17	688-45997-01-00	SPACER 2	1	
18	92990-18200-00	WASHER	1	
19	90171-18M04-00	NUT, CASTLE	1	

CONTINUED ON NEXT FRAME >

LOWER CASING DRIVE 2

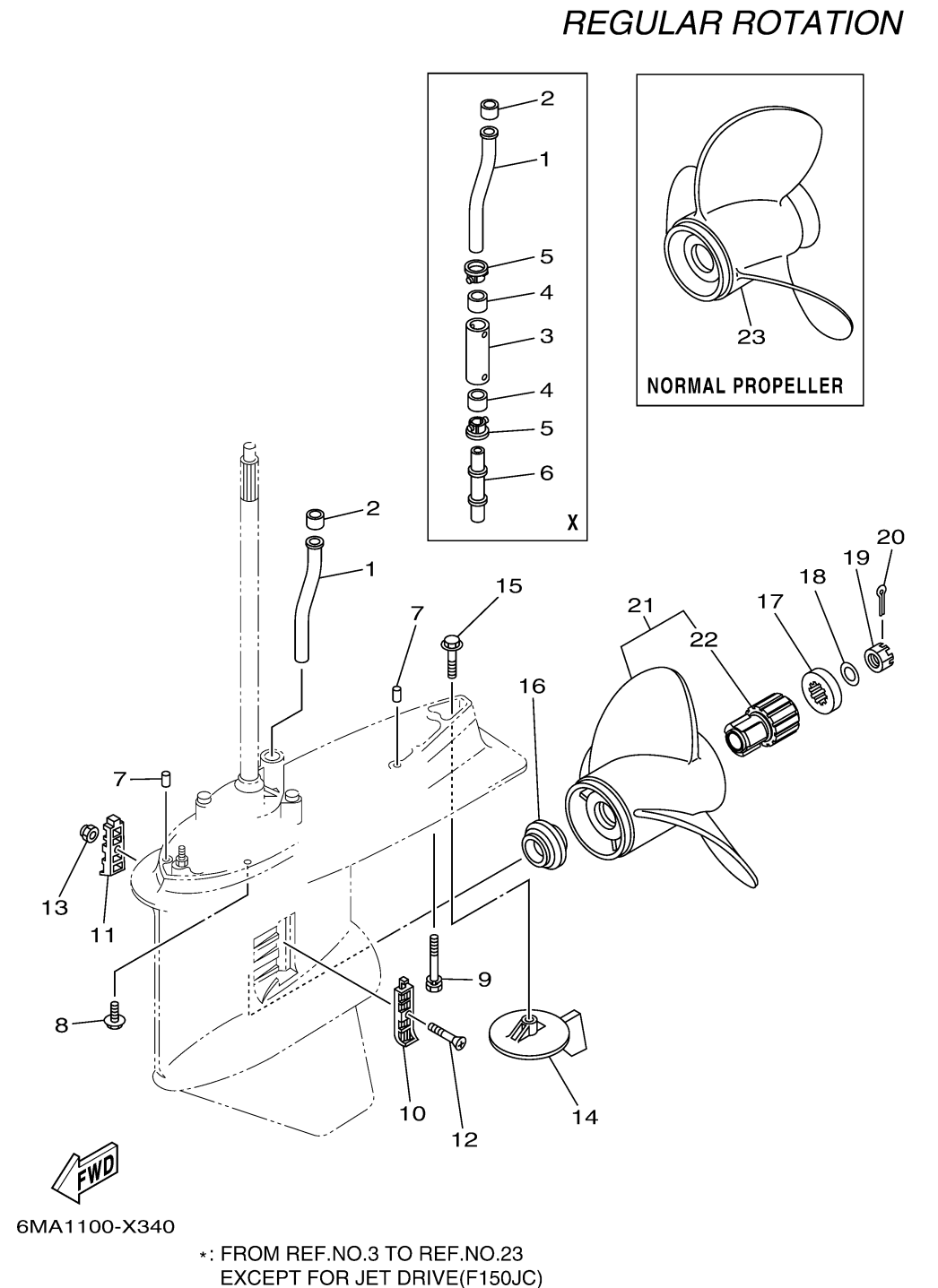

Ref No.	Part Number	Description	Qty	Remarks
20	91490-40030-00	PIN. COTTER	1	
21	68F-45970-20-00	PROPELLER (3X14-1/2"X15"-M)	1	UR SDS PROP.
21	68F-45972-20-00	PROPELLER (3X14-1/4"X17"-M)	1	UR SDS PROP.
21	68F-45978-20-00	PROPELLER (3X14-1/4"X18"-M)	1	UR SDS PROP.
21	68F-45974-20-00	PROPELLER (3X13-3/4"X19"-M)	1	UR SDS PROP.
21	68F-45976-20-00	PROPELLER (3X13-3/4"X21"-M)	1	UR SDS PROP.
21	68F-45932-20-00	PROPELLER (3X14-1/2"X13"-M)	1	UR SDS PROP.
21	68F-45930-20-00	PROPELLER (3X14-1/2"X14"-M)	1	UR SDS PROP.
21	6CE-45970-20-00	PROPELLER (3X15-1/4"X19"-T)	1	UR SDS PROP.
21	6CE-45972-20-00	PROPELLER (3X15"X21"-T)	1	UR SDS PROP.
21	6CE-45974-20-00	PROPELLER (3X14-3/4"X23"-T)	1	UR SDS PROP.
21	6CE-45934-20-00	PROPELLER (3X15-1/4"X18"-T)	1	UR SDS PROP.
21	6CE-45932-20-00	PROPELLER (3X15"X20"-T)	1	UR SDS PROP.
21	6CE-45936-20-00	PROPELLER (3X14-3/4"X22"-T)	1	UR SDS PROP.
21	60H-45970-00-00	PROPELLER (3X14-1/4"X14"-M)	1	UR SDS PROP.
21	60H-45972-00-00	PROPELLER (3X14-1/4"X16"-M)	1	UR SDS PROP.
21	60H-45974-00-00	PROPELLER (3X14-1/4"X18"-M)	1	UR SDS PROP.
21	60H-45976-00-00	PROPELLER (3X14-1/4"X20"-M)	1	UR SDS PROP.
21	60H-45978-00-00	PROPELLER (3X14-1/4"X22"-M)	1	UR SDS PROP.
22	6CE-45C81-10-00	..DAMPER RUBBER, PROPELLER 1	1	

CONTINUED ON NEXT FRAME >

LOWER CASING DRIVE 2

Ref No.	Part Number	Description	Qty	Remarks
23	6G5-45941-00-00	PROPELLER (3X15-1/4"X15"-M)	1	UR NORMAL PROP.
23	6G5-45943-01-00	PROPELLER (3X13-3/4"X21"-M)	1	UR NORMAL PROP.
23	6G5-45945-01-00	PROPELLER (3X14"X19"-M)	1	UR NORMAL PROP.
23	6G5-45947-01-00	PROPELLER (3X14-1/2"X17"-M)	1	UR NORMAL PROP.
23	6G5-45949-00-00	PROPELLER (3X13-1/2"X23"-M)	1	UR NORMAL PROP.
23	6G5-45952-00-00	PROPELLER (3X14-5/8"X16"-M)	1	UR NORMAL PROP.
23	6G5-45970-02-00	PROPELLER (3X15-1/4"X15"-M)	1	UR NORMAL PROP.
23	6G5-45972-02-00	PROPELLER (3X13-3/4"X21"-M)	1	UR NORMAL PROP.
23	6G5-45974-03-00	PROPELLER (3X13-3/4"X19"-M2)	1	UR NORMAL PROP.
23	6G5-45976-01-00	PROPELLER (3X13-3/8"X23"-M)	1	UR NORMAL PROP.
23	6G5-45978-03-00	PROPELLER (3X13-3/4"X17"-M2)	1	UR NORMAL PROP.

REGULAR ROTATION

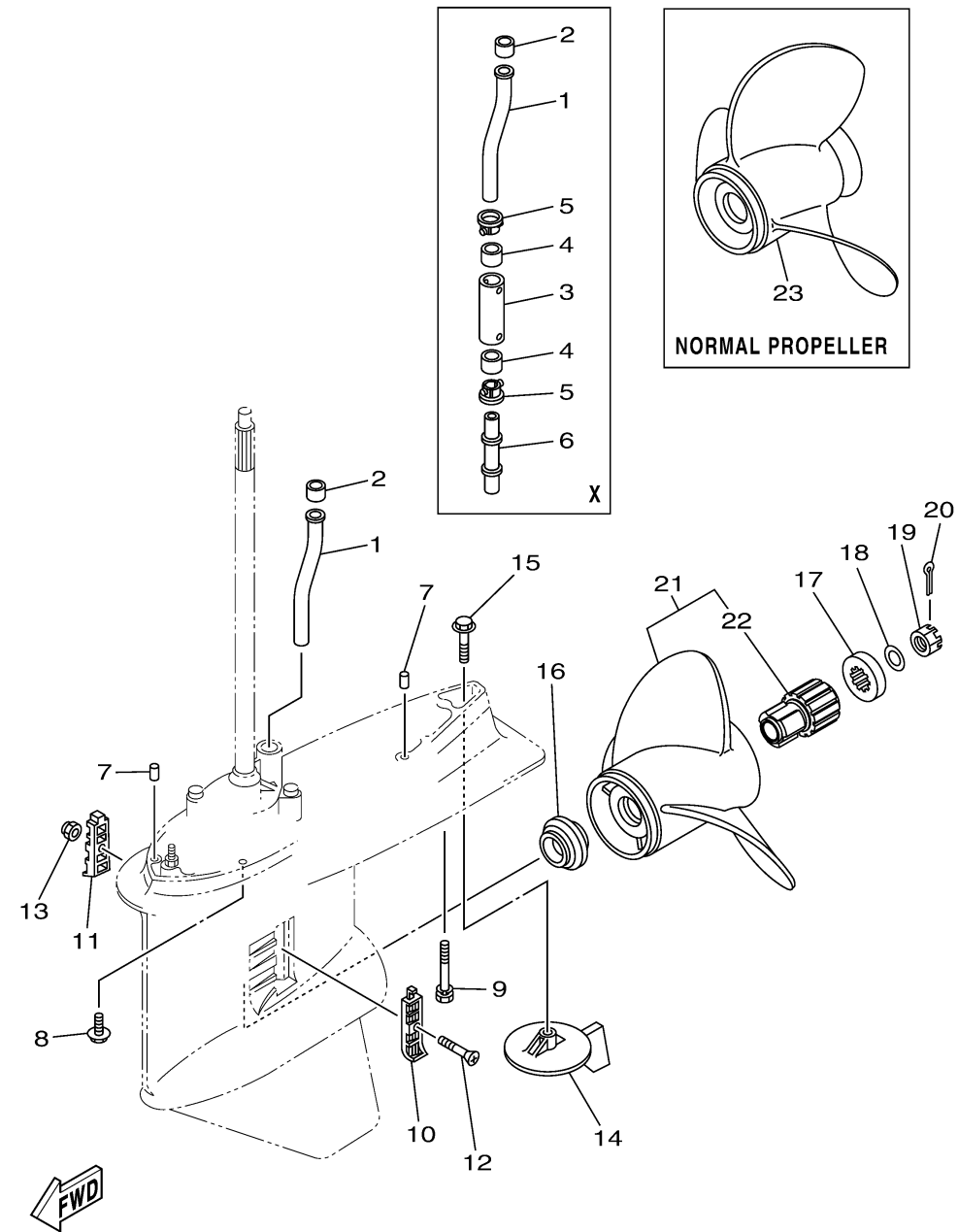

6MA1100-X340

*: FROM REF.NO.3 TO REF.NO.23
EXCEPT FOR JET DRIVE(F150JC)