

ELECTRICAL 4

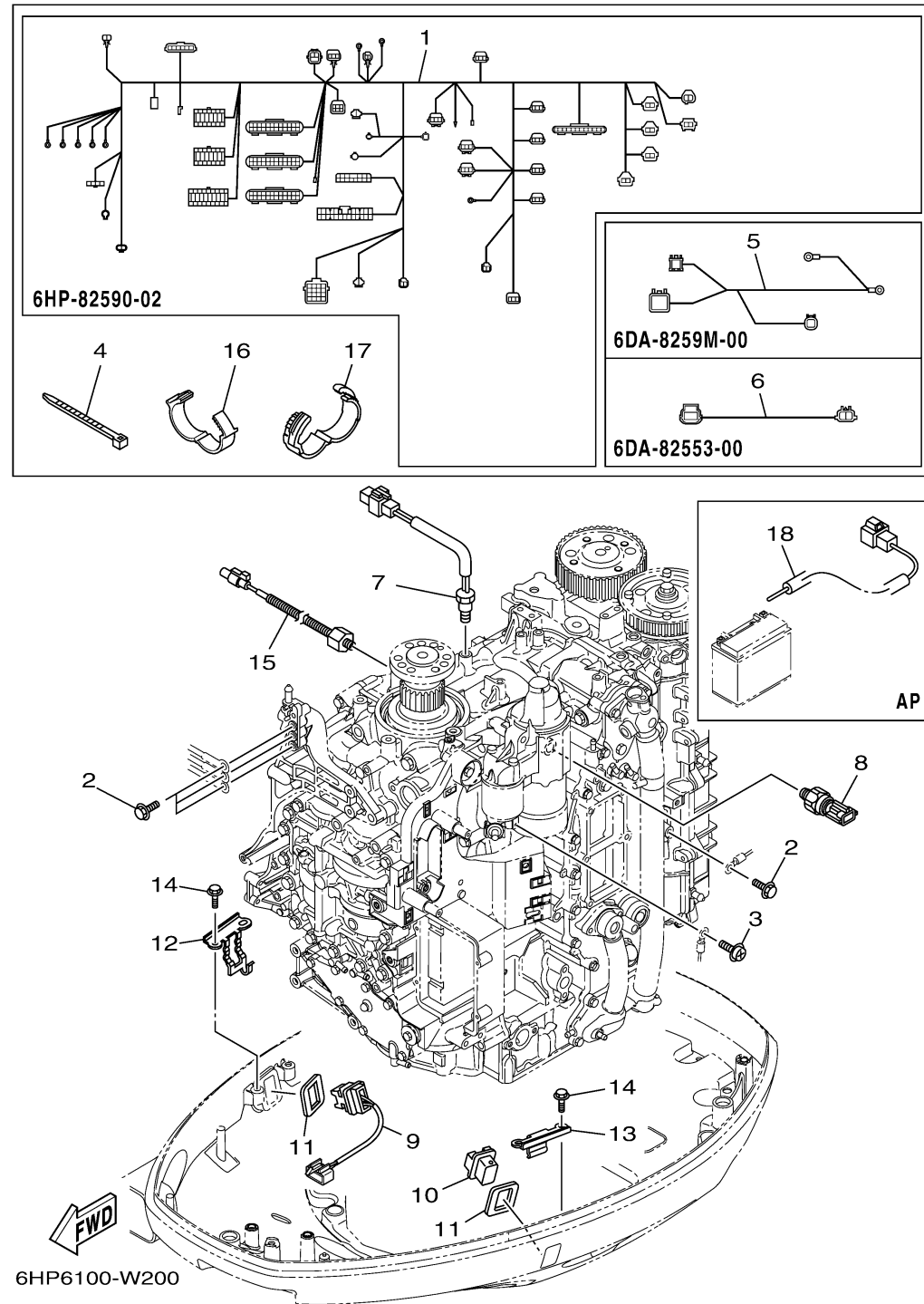

Ref No.	Part Number	Description	Qty	Remarks
1	6HP-82590-02-00	WIRE HARNESS ASSY	1	
2	97E95-06516-00	BOLT, HEXAGON W/W DEEP RECESS	4	
3	97985-04308-00	SCREW, WITH WASHER	1	
4	90465-11M59-00	CLAMP	1	
5	6DA-8259M-00-00	WIRE HARNESS ASSY 2	1	
6	6DA-82553-00-00	EXTENSION, WIRE LEAD	1	
7	6CB-85790-00-00	THERMOSENSOR ASSY	1	
8	6AW-83651-01-00	SENDER, OIL PRESSURE	1	
9	6BR-82563-01-00	TRIM & TILT SWITCH ASSY	1	
10	69J-42723-01-00	COVER, BOTTOM	1	
11	69J-82587-01-00	GASKET	2	
12	63P-83614-01-00	BRACKET	1	
13	6DA-83614-00-00	BRACKET	1	
14	95D95-06012-00	BOLT, FLANGE DEEP RECESS	4	
15	6CJ-85780-01-00	SENSOR, KNOCK	1	
16	90464-26001-00	CLAMP	5	
17	90464-28003-00	CLAMP	2	
18	69J-81949-03-00	WIRE, LEAD (ISOLATOR, 3.8M)	1	AP