

BRACKET 2

Ref No.	Part Number	Description	Qty	Remarks
1	67H-83672-02-00	TRIM SENDER	1	
2	97985-06216-00	SCREW, WITH WASHER	2	
3	64E-43139-11-00	CAM, TRIM SENDER	1	
4	90159-05059-00	SCREW, WITH WASHER	1	
5	90465-11M10-00	.CLAMP	2	
6	6EK-42510-00-8D	STEERING BRACKET ASSY	1	GRAY, L(20.3")
6	6EK-42510-10-8D	STEERING BRACKET ASSY	0	GRAY, X(25.3")
6	6EK-42510-10-CE	STEERING BRACKET ASSY	0	WHITE, X(25.3")
6	6EK-42510-00-CE	STEERING BRACKET ASSY	0	WHITE, L(20.3")
7	90338-08174-00	PLUG	2	
8	90201-38M60-00	WASHER, PLATE	2	
9	93210-37MH7-00	O-RING	1	
10	90386-38M32-00	BUSH	2	
11	90202-40M47-00	WASHER, PLATE	1	
12	6EK-44551-00-CE	HOUSING, LOWER MOUNT RUBBER 1	0	WHITE
12	6EK-44551-00-8D	HOUSING, LOWER MOUNT RUBBER 1	1	GRAY
13	93410-37M04-00	CIRCLIP	1	
14	61A-44575-01-00	DAMPER, LOWER MOUNT RUBBER	1	
15	63P-44555-00-00	MOUNT DAMPER, LOWER SIDE	2	
16	90202-32M19-00	WASHER, PLATE	2	

CONTINUED ON NEXT FRAME >

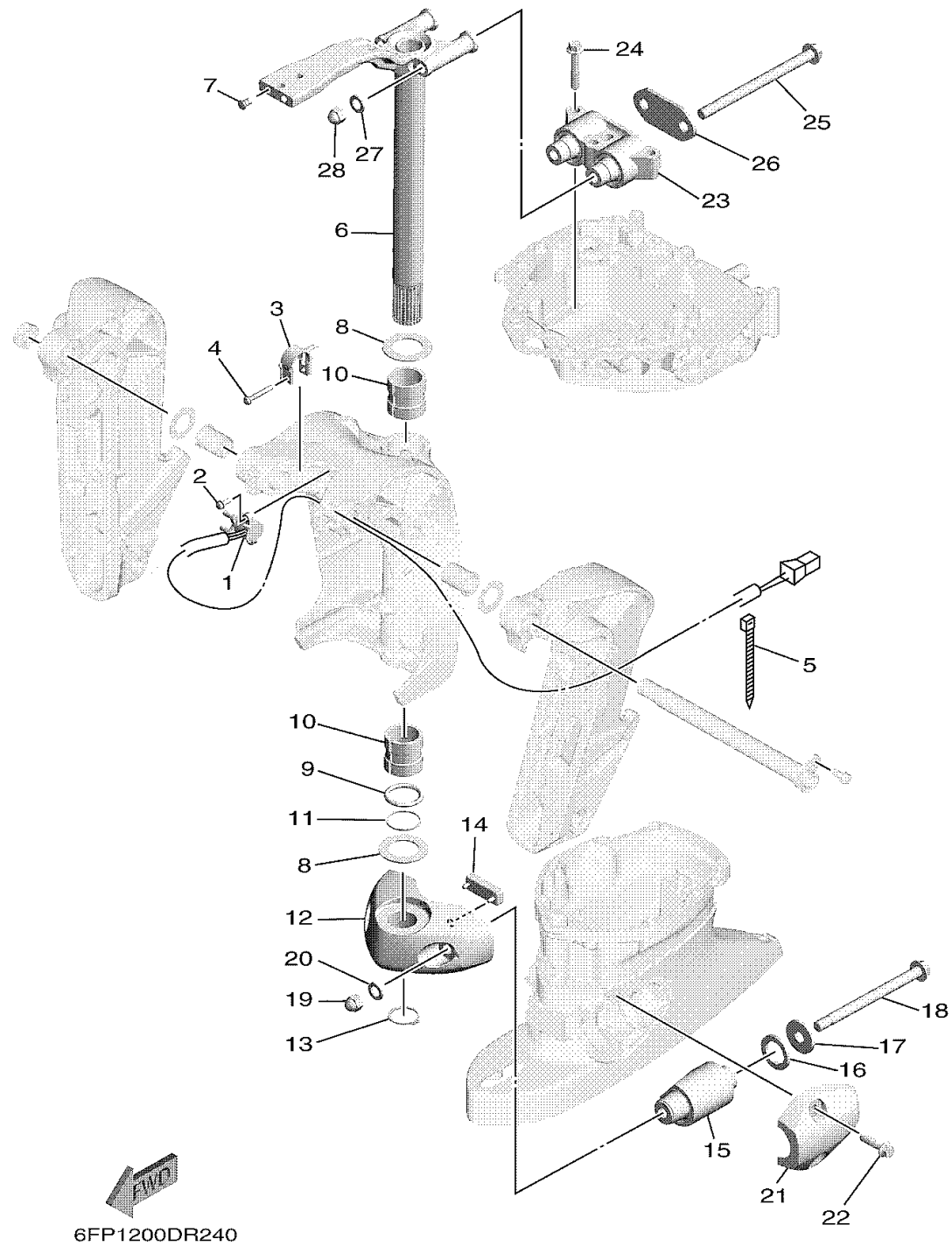

BRACKET 2

Ref No.	Part Number	Description	Qty	Remarks
17	90201-16M55-00	WASHER, PLATE	2	
18	90105-14013-00	BOLT, FLANGE	2	
19	90176-14002-00	NUT, CAP	2	
20	92995-14600-00	WASHER	2	
21	6EK-44553-00-CE	COVER, LOWER MOUNT	0	WHITE
21	6EK-44553-00-8D	COVER, LOWER MOUNT	2	GRAY
22	90119-10058-00	BOLT, WITH WASHER	4	
23	6FP-44514-00-00	MOUNT DAMPER, UPPER SIDE	1	
24	95D75-10060-00	BOLT, FLANGE DEEP RECESS	3	
25	90105-14007-00	BOLT, FLANGE	2	
26	6EK-44526-00-00	PLATE	1	
27	92995-14600-00	WASHER	2	
28	90176-14002-00	NUT, CAP	2	