

LOWER CASING DRIVE 1

Ref No.	Part Number	Description	Qty	Remarks
1	6FM-45300-13-8D	LOWER UNIT ASSY	0	L(21.7")
1	6FM-45300-03-8D	LOWER UNIT ASSY	1	S(16.7")
2	6L2-45311-02-8D	CASING, LOWER	1	
3	93332-00005-00	BEARING	1	
4	6L2-45567-00-00	SHIM (T:1.0MM)	1	UR
4	6L2-45567-10-00	SHIM (T:1.1MM)	1	UR
4	6L2-45567-20-00	SHIM (T:1.2MM)	1	UR
4	6L2-45567-30-00	SHIM (T:1.3MM)	1	UR
4	6L2-45567-40-00	SHIM (T:1.4MM)	1	UR
5	93315-220V9-00	BEARING	1	
6	6L2-45536-00-00	SLEEVE, DRIVE SHAFT	1	
7	90340-08002-00	PLUG, STRAIGHT SCREW	2	
8	90430-08003-00	.GASKET	2	
9	6L2-44311-01-00	.HOUSING, WATER PUMP	1	
10	93210-45161-00	.O-RING	1	
11	6L2-44322-00-00	.INSERT, CARTRIDGE	1	
12	6FM-44323-01-00	.OUTER PLATE, CARTRIDGE	1	
13	6L2-44367-11-00	.DAMPER, WATER SEAL 3	1	
14	6L2-44352-00-00	.IMPELLER	1	
15	97E95-06540-00	.BOLT, HEXAGON W/W DEEP RECESS	4	

CONTINUED ON NEXT FRAME >

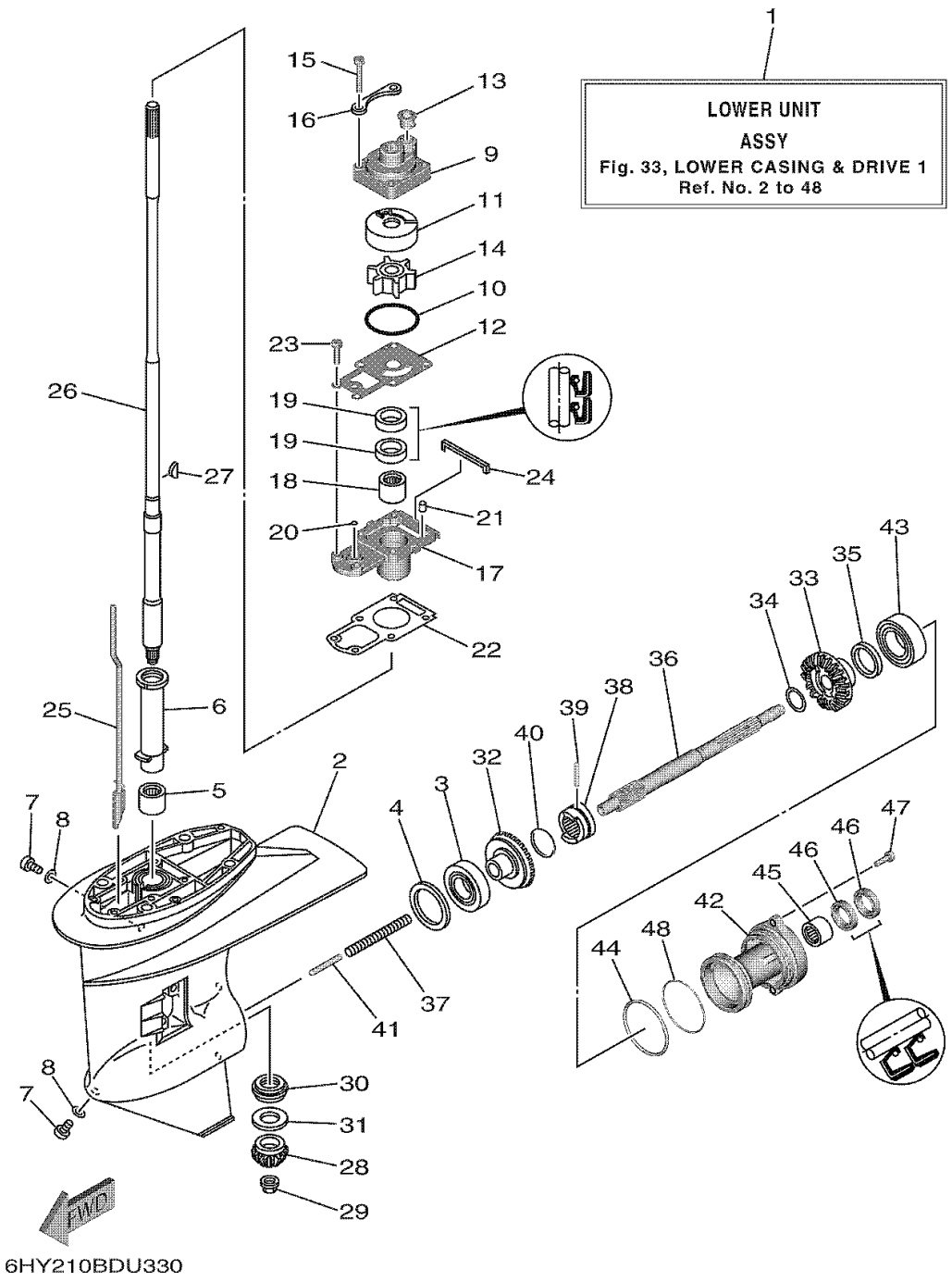

LOWER CASING DRIVE 1

Ref No.	Part Number	Description	Qty	Remarks
16	6L2-44328-00-00	.PLATE	2	
17	6FM-45331-00-CA	HOUSING, BEARING	1	
18	93315-22004-00	BEARING	1	
19	93101-20048-00	.OIL SEAL	2	
20	93210-06ME6-00	.O-RING	1	
21	93604-12M07-00	PIN, DOWEL	2	
22	6L2-45315-A0-00	.PACKING, LOWER CASING	1	
23	97080-06020-00	BOLT	2	
24	6L2-45375-00-00	DAMPER, SEAL	1	
25	6FM-44150-01-00	SHIFT CAM ASSY	1	S(16.7")
25	6FM-44150-11-00	SHIFT CAM ASSY	0	L(21.7")
26	6FM-45510-00-00	DRIVE SHAFT ASSY	1	S(16.7")
26	6FM-45510-10-00	DRIVE SHAFT ASSY	0	L(21.7")
27	90280-03024-00	.KEY, WOODRUFF	1	
28	6L2-45551-01-00	PINION (13T)	1	
29	90179-10M14-00	NUT	1	
30	93341-320U0-00	BEARING	1	
31	6L2-45587-00-00	SHIM (T:1.5MM)	1	UR
31	6L2-45587-10-00	SHIM (T:1.6MM)	1	UR
32	6FM-45560-00-00	GEAR 1 (27T)	1	

CONTINUED ON NEXT FRAME >

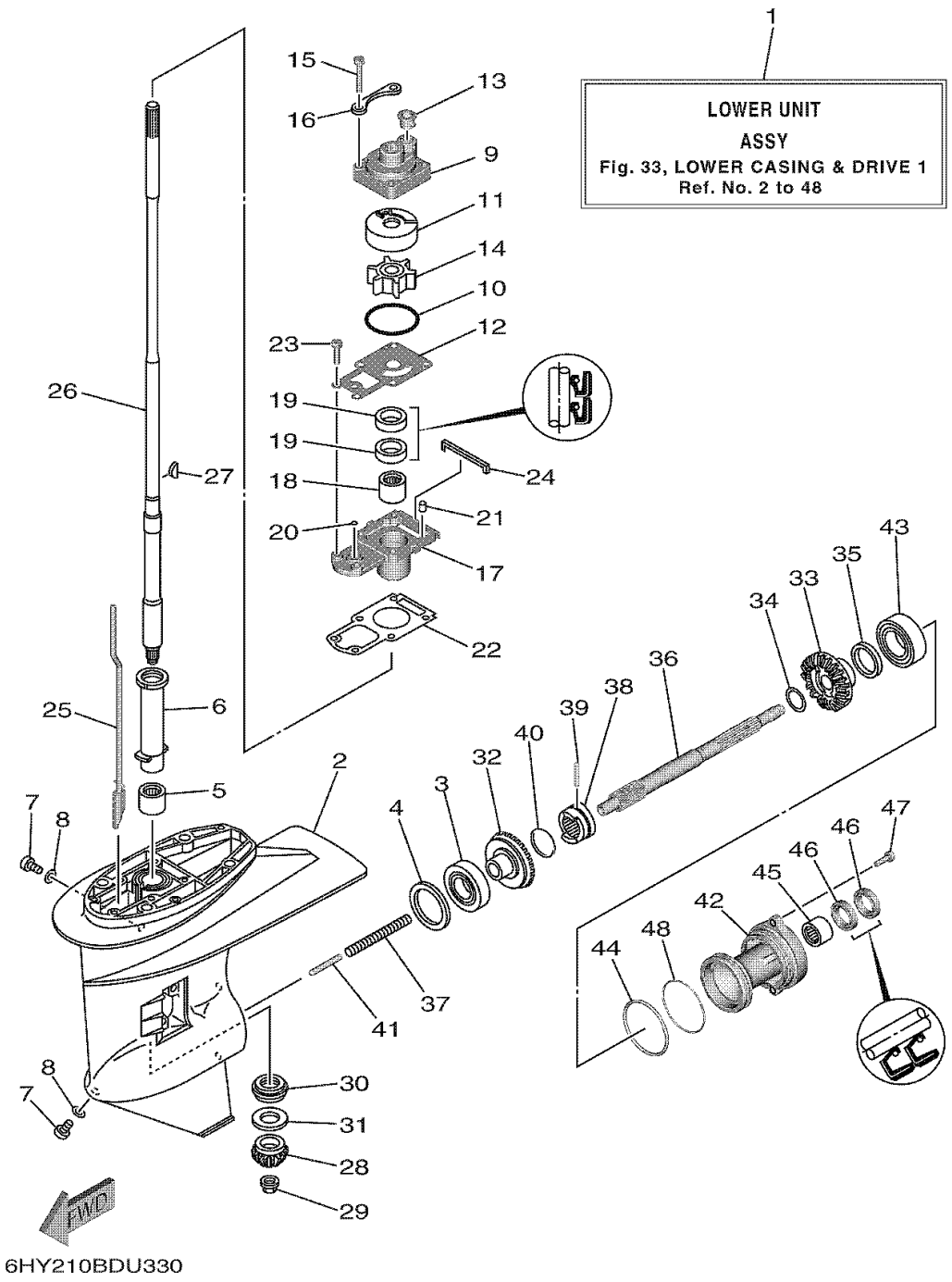

LOWER CASING DRIVE 1

Ref No.	Part Number	Description	Qty	Remarks
33	6FM-45571-00-00	GEAR 2 (27T)	1	
34	90201-20417-00	WASHER, PLATE	1	
35	6L2-45577-20-00	SHIM (T:1.2MM)	1	UR
35	6L2-45577-10-00	SHIM (T:1.1MM)	1	UR
35	6L2-45577-00-00	SHIM (T:1.0MM)	1	UR
35	6L2-45577-30-00	SHIM (T:1.3MM)	1	UR
36	65W-45611-00-00	SHAFT, PROPELLER	1	
37	90501-10065-00	SPRING, COMPRESSION	1	
38	6FM-45631-00-00	CLUTCH, DOG	1	
39	90250-05010-00	PIN, STRAIGHT	1	
40	648-45633-11-00	RING, CROSS PIN	1	
41	648-45635-00-00	PLUNGER, SHIFT	1	
42	6L2-45361-03-8D	CAP, LOWER CASING	1	
43	93306-00612-00	BEARING	1	
44	93210-60MA3-00	.O-RING	1	
45	93315-22004-00	BEARING	1	
46	93101-20M07-00	.OIL SEAL	2	
47	97E95-06520-00	BOLT, HEXAGON W/W DEEP RECESS	2	
48	93210-60M99-00	.O-RING	1	